

# **GSB 15**

## **USB Database and Charging Hub**

### **Installation Manual**



© 2021  
Garmin Ltd. or its subsidiaries  
All Rights Reserved

Except as expressly provided herein, no part of this manual may be reproduced, copied, transmitted, disseminated, downloaded or stored in any storage medium, for any purpose without the express prior written consent of Garmin. Garmin hereby grants permission to download a single copy of this manual and of any revision to this manual onto a hard drive or other electronic storage medium to be viewed and to print one copy of this manual or of any revision hereto, provided that such electronic or printed copy of this manual or revision must contain the complete text of this copyright notice and provided further that any unauthorized commercial distribution of this manual or any revision hereto is strictly prohibited.

Garmin International, Inc.  
1200 E. 151st Street  
Olathe, KS 66062 USA  
[www.garmin.com](http://www.garmin.com)

Garmin (Europe) Ltd.  
Liberty House, Hounsdown Business Park  
Southampton, Hampshire SO40 9LR U.K.

### **AVIATION LIMITED WARRANTY**

GSB 15 warranty information is available at [garmin.com/aviationwarranty](http://garmin.com/aviationwarranty).

### **RECORD OF REVISIONS**

<b>Revision</b>	<b>Revision Date</b>	<b>Description</b>
2	07/18/19	Added mounting kit info
3	10/13/20	Added Decorative Cover info
4	02/22/21	Added Type-C unit info
5	02/24/21	Added mounting kit applicability to Type-C units
6	03/11/21	Updated output power specs

**INFORMATION SUBJECT TO EXPORT CONTROL LAWS**

This document may contain information which is subject to the Export Administration Regulations (“EAR”) issued by the United States Department of Commerce (15 CFR, Chapter VII Subchapter C) and which may not be exported, released or disclosed to foreign nationals inside or outside the United States without first obtaining an export license. The preceding statement is required to be included on any and all reproductions in whole or in part of this manual.

**CURRENT REVISION DESCRIPTION**

<b>Revision</b>	<b>Page Number</b>	<b>Section Number</b>	<b>Description of Change</b>
6	1-7	<a href="#">1.5.2</a>	Updated Output Power Specs

## DEFINITIONS OF WARNINGS, CAUTIONS, AND NOTES



### **WARNING**

*A warning means injury or death is possible if the instructions are not obeyed.*



### **CAUTION**

*A caution means that damage to the equipment is possible.*



### **NOTE**

*A note gives more information.*



### **WARNING**

*This product, its packaging, and its components contain chemicals known to the State of California to cause cancer, birth defects, or reproductive harm. This Notice is being provided in accordance with California's Proposition 65. If you have any questions or would like additional information, please refer to our web site at <http://www.garmin.com/prop65>.*

## SOFTWARE LICENSE AGREEMENT

BY USING THE DEVICE, COMPONENT OR SYSTEM MANUFACTURED OR SOLD BY GARMIN (“THE GARMIN PRODUCT”), YOU AGREE TO BE BOUND BY THE TERMS AND CONDITIONS OF THE FOLLOWING SOFTWARE LICENSE AGREEMENT. PLEASE READ THIS AGREEMENT CAREFULLY. Garmin Ltd. and its subsidiaries (“Garmin”) grants you a limited license to use the software embedded in the Garmin Product (the “Software”) in binary executable form in the normal operation of the Garmin Product. Title, ownership rights, and intellectual property rights in and to the Software remain with Garmin and/or its third-party providers. You acknowledge that the Software is the property of Garmin and/or its third-party providers and is protected under the United States of America copyright laws and international copyright treaties. You further acknowledge that the structure, organization, and code of the Software are valuable trade secrets of Garmin and/or its third-party providers and that the Software in source code form remains a valuable trade secret of Garmin and/or its third-party providers. You agree not to reproduce, decompile, disassemble, modify, reverse assemble, reverse engineer, or reduce to human readable form the Software or any part thereof or create any derivative works based on the Software. You agree not to export or re-export the Software to any country in violation of the export control laws of the United States of America.

Qualcomm and Quick Charge are trademarks or registered trademarks of Qualcomm Incorporated.



All Qualcomm Incorporated trademarks are used with permission.

Qualcomm Quick Charge is a product of Qualcomm Technologies, Inc. and/or its subsidiaries.

**TABLE OF CONTENTS**

<b>PARAGRAPH</b>	<b>PAGE</b>
<b>Section 1 Declaration of Design and Performance .....</b>	<b>1-1</b>
1.1 Introduction.....	1-1
1.2 Description and Identification .....	1-1
1.3 Certification Statement .....	1-5
1.4 Interface Summary.....	1-6
1.5 Performance Technical Specifications.....	1-7
1.6 Limitations .....	1-8
1.7 Operating Instructions.....	1-8
1.8 License Requirements.....	1-8
1.9 Reference Documents .....	1-8
 <b>Section 2 Installation Overview .....</b>	 <b>2-1</b>
2.1 Introduction.....	2-1
2.2 Installation Materials Required but not Supplied .....	2-1
2.3 Installation Configurations .....	2-1
2.4 Special Tools Required .....	2-1
2.5 Cabling and Wiring.....	2-2
2.6 Shielding and Electrical Bonding Considerations .....	2-2
2.7 Cooling Requirements or Considerations .....	2-2
2.8 Mounting Requirements .....	2-3
 <b>Section 3 Installation Procedure.....</b>	 <b>3-1</b>
3.1 Wiring Harness Installation .....	3-1
3.2 Equipment Mounting .....	3-1
3.3 Decorative Cover Installation .....	3-2
 <b>Section 4 Post Installation Configuration &amp; Checkout .....</b>	 <b>4-1</b>
4.1 Mounting, Wiring, and Power Checks.....	4-1
4.2 Configuration Setup .....	4-1
4.3 Diagnostic Information .....	4-1
4.4 Ground Checks .....	4-1
4.5 Software Loading Procedure .....	4-1
 <b>Section 5 Continued Airworthiness.....</b>	 <b>5-1</b>
 <b>Section 6 Connector Pinout Information.....</b>	 <b>6-1</b>
6.1 Pin Function List.....	6-1
 <b>Appendix A Outline and Installation Drawings .....</b>	 <b>A-1</b>
 <b>Appendix B Interconnect Drawings.....</b>	 <b>B-1</b>

# 1 DECLARATION OF DESIGN AND PERFORMANCE

## 1.1 Introduction

The Declaration of Design and Performance section contains the definition and statement of compliance of the GSB 15. The section is written in accordance with European Aviation Safety Agency (EASA) Commission Regulation (EU) No 748/2012 date 3 August 2012.

The full manual is intended to provide mechanical and electrical information for use in the planning and design of an installation of the GSB 15 into an aircraft. This manual is not a substitute for an approved airframe-specific maintenance manual, installation design drawing, or complete installation data package. Attempting to install equipment by reference to this manual alone and without first planning or designing an installation specific to your aircraft may compromise your safety and it is not recommended. The content of this manual assumes use by competent and qualified avionics engineering personnel and/or avionics installation specialist using standard maintenance practices in accordance with Title 14 of the Code of Federal Regulation and other relevant accepted practices. This manual is not intended for use by individuals who do not possess the competencies and abilities set forth above.



### NOTE

*Garmin recommends installation of the GSB 15 by a Garmin-authorized installer. To the extent allowable by law, Garmin will not be liable for damages resulting from improper or negligent installation of the GSB 15. For questions, please contact Garmin Aviation Product Support at 1-888-606-5482.*



### NOTE

*Except where specifically noted, references to GSB 15 apply equally to all GSB 15 variants.*

## 1.2 Description and Identification

The GSB 15 functions as a USB Database and Charging Hub that provides:

- Two (2) USB charging ports
- Optional software and database loading to compatible Garmin devices via USB
- Halo backlighting to facilitate nighttime usability

There are three variants of the GSB 15:

- GSB 15 Dual Type-A (011-04937-00, -01) units:  
Two (2) USB Type-A connectors for charging and data transfer
- GSB 15 Type-A and Type-C (011-04937-20, -30) units:  
One (1) USB Type-A and one (1) USB Type-C connectors for charging and data transfer
- GSB 15 Dual Type-C (011-04937-40, -50) units:  
Two (2) USB Type-C connectors for charging and data transfer

### 1.2.1 Unit Identification

The GSB 15 can be identified by the part numbers listed in Table 1-1.

**Table 1-1 GSB 15 Unit Identification**

API	Marketing Label	Garmin P/N (Unit Only)	Garmin P/N (Shipping Level)
GMN-02201	GSB 15	011-04937-0( ) through 011-04937-1( )	010-02201-0( ) through 010-02201-1( )
GMN-02544	GSB 15	011-04937-2( ) through 011-04937-5( )	010-02544-2( ) through 010-02544-5( )

The GSB 15 is currently available in the following configurations.

**Table 1-2 GSB 15 Part Numbers**

Model	Unit Only P/N	Unit Only Shipping P/N	Standard P/N [1]
GSB 15, Dual Type-A, Rear	011-04937-00	010-02201-00	010-02201-10
GSB 15, Dual Type-A, Side	011-04937-01	010-02201-01	010-02201-11
GSB 15, Type-A and Type-C, Rear	011-04937-20	010-02544-20	010-02544-21
GSB 15, Type-A and Type-C, Side	011-04937-30	010-02544-30	010-02544-31
GSB 15, Dual Type-C, Rear	011-04937-40	010-02544-40	010-02544-41
GSB 15, Dual Type-C, Side	011-04937-50	010-02544-50	010-02544-51

[1] Includes connector kit (011-05044-00)

### 1.2.2 Accessories

The following accessories are provided separately from the GSB 15.

**Table 1-3 Required Accessories**

Item	Garmin P/N
GSB 15 Connector Kit	011-05044-00



**Table 1-4 Optional Accessories**

Item	Garmin P/N
GSB 15 2.25" Mounting Kit	011-05043-00
GSB 15 3.125" Mounting Kit	011-05043-01
GSB 15 Decorative Cover (unfinished) [1]	011-05291-00
GSB 15 Decorative Cover (black powder coat) [1]	011-05291-01

[1] Accessories are for decorative purposes only and are not TSO qualified. Installation of the Decorative Cover accessories does not affect the TSO functions of the GSB 15.

**Table 1-5 Contents of 2.25" Mounting Kit (011-05043-00)**

Item	Garmin P/N	Quantity
DCP, Adapter Plate, 2.25"	125-00581-02	1
Screw, 4-40 x .250, FLHP 100, SS/BO	211-63304-08	2

**Table 1-6 Contents of 3.125" Mounting Kit (011-05043-01)**

Item	Garmin P/N	Quantity
DCP, Adapter Plate, 3.125"	125-00581-12	1
Screw, 4-40 x .250, FLHP 100, SS/BO	211-63304-08	2

**Table 1-7 Contents of Connector Kit (011-05044-00)**

Item	Garmin P/N	Quantity
Screw, 4-40x.125, PHP, SS/P, w/NYL	211-60234-04	1
Screw, 4-40x.250, PHP-STD, SS/BO	211-60304-08	2
Term, Ring, Ins, #4, 22-26 AWG	235-00117-01	1
Conn, Hsg, Rcpt, 3mm P, Single Row, Locking, 6 CKT, Nylon	330-00771-05	1
Contact, Female, Crimp, 20-24 AWG, 15u Gold	336-00065-05	6

**Table 1-8 Contents of Decorative Cover, Unfinished (011-05291-00)**

Item	Garmin P/N	Quantity
SMP, Decorative Cover, GSB 15, w/VHB	115-03439-01	1
DCP, Decorative Cover, GSB 15, Unfinished	125-00627-02	1
Screw, 4-40x.312, FLHP100, SS/P	211-63204-09	2

**Table 1-9 Contents of Decorative Cover, Black Powder Coat (011-05291-01)**

Item	Garmin P/N	Quantity
SMP, Decorative Cover, GSB 15, w/VHB	115-03439-01	1
DCP, Decorative Cover, GSB 15, Black Powder Coat	125-00627-03	1
Screw, 4-40x.312, FLHP100, SS/P	211-63204-09	2

### 1.2.3 Physical Characteristics

**Table 1-10 Unit and Accessory Weights**

Model	Part Number	Weight
GSB 15 (all models)	011-04937-00, -01,-20, -30, -40, -50	0.16 lbs (0.07 kg)
GSB 15 2.25" Mounting Kit	011-05043-00	0.11 lbs (0.05 kg)
GSB 15 3.125" Mounting Kit	011-05043-01	0.20 lbs (0.09 kg)
GSB 15 Connector Kit	011-05044-00	0.01 lbs (0.005 kg)
GSB 15 Decorative Cover, Unfinished	011-05291-00	0.03 lbs (0.01 kg)
GSB 15 Decorative Cover, Black Powder Coat	011-05291-01	0.03 lbs (0.01 kg)

### 1.2.4 Mod Level History

The following tables identify hardware modification (Mod) Levels for the GSB 15. Mod Levels are listed with the associated service bulletin number, service bulletin date, and the purpose of the modification. The table is current at the time of publication of this manual (see date on front cover) and is subject to change without notice. Authorized Garmin Sales and Service Centers are encouraged to access the most up-to-date bulletin and advisory information on the Garmin Dealer Resource web site at [www.garmin.com](http://www.garmin.com) using their Garmin-provided user name and password.

**Table 1-11. MOD Level History**

Applicable LRU Part Number	MOD Level	Service Bulletin Number & Date	Purpose of Modification
011-04937-00	N/A	N/A	N/A
011-04937-01	N/A	N/A	N/A
011-04937-20	N/A	N/A	N/A
011-04937-30	N/A	N/A	N/A
011-04937-40	N/A	N/A	N/A
011-04937-50	N/A	N/A	N/A

### 1.3 Certification Statement

The GSB 15 has been shown to meet compliance with the claimed TSO(s) when interfaced with the equipment defined in this installation manual, and installed in accordance with the requirements and limitations as defined in this installation manual.

The installer must verify that non-Garmin devices to be interfaced meet the installation requirements identified in this manual to assure the installed system will comply with the Garmin TSO Authorization. Garmin installation requirements will usually specify that the interfaced device has appropriate TSO authorization, and in some cases, such as for TSO-C144 antennas, may also require that the non-Garmin device meet additional Garmin specifications.

The conditions and tests required for TSO approval of this article are minimum performance standards. Those installing this article either on or within a specific type or class of aircraft must determine that the aircraft installation conditions are within the TSO standards which include any accepted integrated non-TSO functions. TSO articles and any accepted integrated non-TSO function(s) must have separate approval for installation in an aircraft. The article may be installed only according to 14 CFR part 43 or the applicable airworthiness requirements.

In accordance with the Bilateral Oversight Board, Decision 006, for the Agreement Between the United States of America and the European Union on Cooperation in the Regulation of Civil Aviation Safety, the FAA TSO authorization makes this an approved article within the respective EASA system. This article was tested to additional standards (see section 1.3.4) that may demonstrate additional airworthiness specification performance standards required by the European Aviation Safety Agency (EASA).

The Appliance Project Identifier (API) for the GSB 15 is GMN-02201 and GMN-02544. The API has been used for project identification with the FAA.

#### 1.3.1 GSB 15 TSO Compliance

**Table 1-12 GSB 15 (011-04937-00, -01, -20, -30, -40, -50) TSO Compliance**

TSO/MOPS*	Function Design	Class/Type	System SW Part Numbers	Boot Block SW Part Numbers	CLD Part Numbers
TSO-C71	Airborne Static (DC to DC) Electrical Power Converter	N/A	N/A	N/A	N/A

\*The Minimum Performance Standards in this table are the conditions and tests used to achieve FAA TSO authorization. See [Section 1.3.4](#) for additional standards.

### 1.3.2 GSB 15 TSO/ETSO Deviations

**Table 1-13 GSB 15 (011-04937-00, -01, -20, -30, -40, -50)TSO Standard Deviations**

TSO	Deviation
TSO-C71	Garmin was granted a deviation to include only product name, part number, serial number, and this statement on the unit's nameplate label: "TSO-C71 See IM for Add'l Appliance Apprvls".
	Garmin was granted a deviation to use RTCA/DO-160F as the standard for Environmental Qualification and Test Procedures of Airborne Equipment.

### 1.3.3 Non-TSO Functions

The GSB 15 has no non-TSO functions.

### 1.3.4 Additional Standards

The GSB 15 has no Additional Standards.

The conditions and tests required for approval of this article are minimum performance standards. Those installing this article either on or within a specific type or class of aircraft must determine that the aircraft installation conditions are within the standards which include any accepted integrated functions not specified by the standard. Articles approved with 14 CFR part 21.8(d) and any accepted integrated function(s) not specified in the standard must have separate approval for installation in an aircraft. The article may be installed only according to 14 CFR part 43 or the applicable airworthiness requirements.

### 1.3.5 Design Assurance Levels

The GSB 15 Dual Type-A (011-04937-00, -01) contains no software or airborne electronic hardware with related design assurance levels.

GSB 15 Type-A and Type-C (011-04937-20, -30) and GSB 15 Dual Type-C (011-04937-40, -50) have COTS SW in the PD charge controller. Design assurance level D is achieved at the subsystem level through hardware over voltage/current protections and 3rd party lab testing for USB PD functionality.

The GSB 15 COTS module provides no design assurance for pass-through data. Those installing this article with other articles utilizing pass-through data must determine means for detecting misleading or corrupt data.

### 1.3.6 Database

For information on certification compliance for databases, refer to Garmin Document P/N 190-01999-00 posted at [flyGarmin.com](http://flyGarmin.com).

## 1.4 Interface Summary

The following list is an interface summary for the GSB 15 units:

- Two (2) USB Type-A and/or Type-C connectors for charging and data transfer
- A USB interface through the rear connector for database/SW loads to Garmin units.

## 1.5 Performance Technical Specifications

### 1.5.1 Environmental Qualification Form Reference

It is the responsibility of the installing agency to obtain the latest revision of the GSB 15 Environmental Qualification Form. To obtain a copy of this form, see the dealer/OEM portion of the Garmin web site ([www.garmin.com](http://www.garmin.com)).

This form is available directly from Garmin under the following part number:

GSB 15 Environmental Qualification Form, Garmin part number 005-01380-03

### 1.5.2 General Specifications

**Table 1-14 General Specifications**

Characteristic	Specification
Qualcomm® Quick Charge™ Technology	Qualcomm® Quick Charge™ Technology delivers up to 75% faster charging vs. conventional USB charging [1]
Output Voltage 011-04937-00, -01 units	Type-A Ports: 5-12VDC +/-5% (5V nominal)
Output Voltage 011-04937-20, -30, -40, -50 units	Type-A Ports: 3.6-12VDC +/-5% (5V nominal) Type-C Ports: 5-12VDC +/-5% (5V nominal)
Output Power (each port) 011-04937-00, -01 units	Type-A Ports: 18W MAX (7.5W Nominal) 5V/3A, 9V/2A, 12V/1.5A
Output Power (each port) 011-04937-20, -30, -40, -50 units	Type-A Ports: 27W MAX (7.5W Nominal) [3] 5V/3A, 9V/3A, 12V/2.25A Type-C Ports: 27W MAX (15W Nominal) [4] 5V/3A, 9V/3A, 12V/2.25A
Operating Temperature Range	-20 to 55 C [2]
Altitude	55,000 ft
Humidity	95% non-condensing

[1] Type-A ports only

[2] GSB 15 may reduce output power at high ambient temperatures depending on the installation environment. See [Section 1.5.4](#) for details.

[3] Output power on Type-A ports is reduced to 7.5W maximum when transferring data.

[4] Output power on Type-C ports is reduced to 15W maximum when transferring data.

### 1.5.3 Power Specifications

**Table 1-15 GSB 15 Power Specifications**

Specification	Dual Type-A (011-04937-00, -01) Units	Type-A and Type-C (011-04937-20, -30) units and Dual Type-C (011-04937-40, -50) Units
Max Power While Charging Both Ports and Backlight Enabled	40W 14V, 2.86A 28V, 1.43A	68W 14V, 4.86A 28V, 2.43A
Max Power With No Devices Connected	500mW 14V, 0.035A	500mW 14V, 0.035A

### 1.5.4 Over-Temperature Protection

The GSB 15 Dual Type-A (011-04937-00, -01) unit is equipped with over-temperature detection and may reduce output power to 5V, 1.5A (max) output current. After the device has cooled, normal output power will resume.

The GSB 15 Type-A and Type-C (011-04937-20, -30) and GSB 15 Dual Type-C (011-04937-40, -50) units are equipped with over-temperature detection. Type-A and Type-C ports may reduce output current to 5V, 1.5A (max) and 5V, 3A (max) respectively. After the device has cooled, normal output power will resume.

### 1.6 Limitations

This article meets the minimum performance and quality control standards required by a technical standard order (TSO). Installation of this article requires separate approval.

### 1.7 Operating Instructions

All GSB 15 units (011-04937-XX) have a configurable backlight. Grounding pin 5 will de-activate the backlight, allowing pin 5 to float enables the backlight. The backlight brightness is calibrated for night-time use and may not be visible in daylight conditions. The GSB 15 Type-A and Type-C (011-04937-20, -30) and GSB 15 Dual Type-C (011-04937-40, -50) units have additional functionality to connect to dimmer bus between 0 VDC and aircraft pwr to set/dim the backlight

It is acceptable and preferred to install only the pins that are needed.



#### **CAUTION**

*Do not apply power to the unit until after the rear connector is completely seated.  
Connecting the unit while power is applied may cause damage to the device, and to other LRUs that are connected to the data lines.*

### 1.8 License Requirements

There are no license requirements applicable to the GSB 15.

### 1.9 Reference Documents

There are no applicable reference documents for installation of the GSB 15.

## 2 INSTALLATION OVERVIEW

### 2.1 Introduction

This section provides the equipment information for installing the GSB 15 and related optional accessories. Installation of the GSB 15 must follow the data detailed in this manual. Cabling is typically fabricated by the installing agency to fit each particular aircraft. Always follow acceptable avionics installation practices per advisory circulars AC 43.13-1B and AC 43.13-2B or later FAA approved revisions.

### 2.2 Installation Materials Required but not Supplied

- All wiring required for installation
- Circuit breaker
- M81824/1-2 (or equivalent) splices may be required for 14V aircraft installation

### 2.3 Installation Configurations

The GSB 15 can be installed in either a rear connector or side connector configuration. Refer to the outline and installation drawings in [Appendix A](#).

Optional 2.25” and 3.125” mounting kits are also available (see [Table 1-3](#)) to mount the GSB 15 in existing instrument panel holes.



#### NOTE

*At least 2 of the 4 provided mounting holes must be used (diagonally from each other) to mount the GSB 15.*

### 2.4 Special Tools Required

A crimp tool is required for the GSB 15 installation. Recommended and optional crimp tools are as follows:

Recommended Crimp tool:

- [Molex Hand Crimp Tool, P/N 638190000](#)

Optional:

- [Molex Insertion Tool for Micro-Fit 3.0 and CRC Male and Female Crimp Terminals, 20-30 AWG, P/N 638120800](#)
- [Molex Extraction Tool, P/N 11030043](#)



## 2.5 Cabling and Wiring

Wiring must be installed in accordance with AC 43.13-1B Chapter 11, Sections 8 through 13. The following issues must be addressed:

- Do not expose cabling and wiring to chafing
- Do not route cabling and wiring harnesses near flight cables
- Do not route cabling and wiring near high-energy sources. (e.g. DC motors, high heat sources)
- Wiring indicated as shielded in Appendix B must be shielded
- Pigtail lengths must be less than 2.5 inches.
- Crimp pins must be installed in accordance with Molex Application Tooling Specification Sheet ATS-638190000 to ensure proper insulation crimp and conductor crimp.



### CAUTION

See [Figure B-1](#) for power and power ground wire info.

## 2.6 Shielding and Electrical Bonding Considerations

Electrical equipment, supporting brackets, and racks must be electrically bonded to the aircraft's main structure or a designated aircraft groundplane. Refer to the following documents for applicable bonding techniques:

- AC 43.13-1B CHG 1, "Acceptable Methods, Techniques, and Practices - Aircraft Inspection and Repair", Chapter 11, "Aircraft Electrical Systems"
- SAE ARP 1870A, "Aerospace Systems Electrical Bonding and Grounding for Electromagnetic Compatibility and Safety"
- A bonding procedure developed and supplied by the aircraft manufacturer (if available)

The electrical bond must achieve direct current (DC) resistance less than or equal to 2.5 milliohms to local structure where the equipment is mounted. Compliance must be verified by inspection using a calibrated milliohm meter.

## 2.7 Cooling Requirements or Considerations

The GSB 15 has no cooling requirements or considerations. Forced air cooling will reduce the internal temperature of the unit and prolong the life of the product.

The GSB 15 may reduce output power at high temperatures depending on the installation environment. See [Section 1.5.4](#) for details.

## 2.8 Mounting Requirements

The small size of the GSB 15 allows it to be installed in many places. It is intended to be installed to the instrument panel or other suitable cabin surface. There are no special requirements for viewing, reach, or proximity. See drawings in [Appendix A](#) for details.

**REAR CONNECTOR (-00/-20/-40 CONFIG) WITH CONNECTOR KIT (011-05044-00)**  
-00 Config Shown

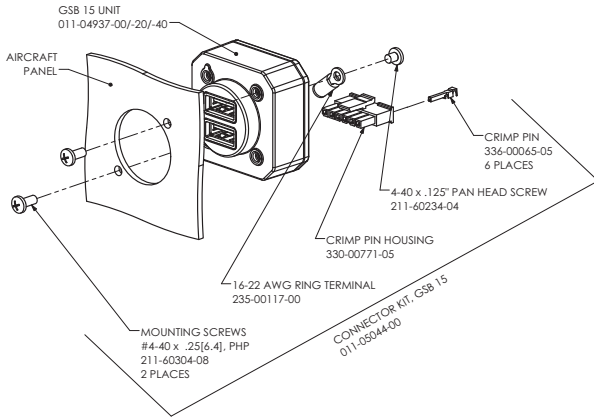

**SIDE CONNECTOR (-01/-30/-50 CONFIG) WITH CONNECTOR KIT (011-05044-00)**  
-01 Config Shown

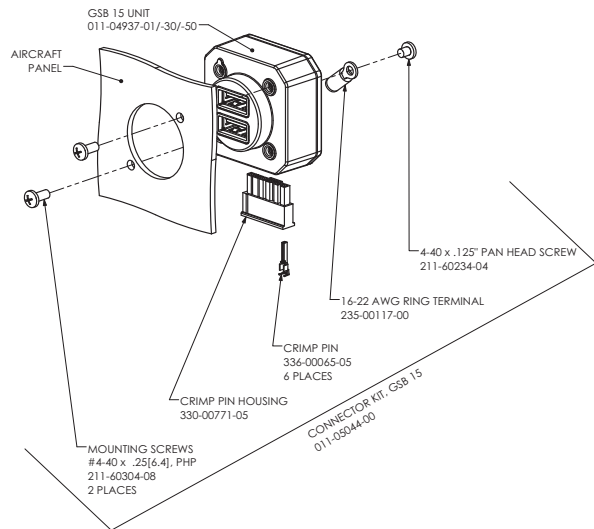

**GSB 15 (ALL CONFIGS) WITH 2.25\"/>**

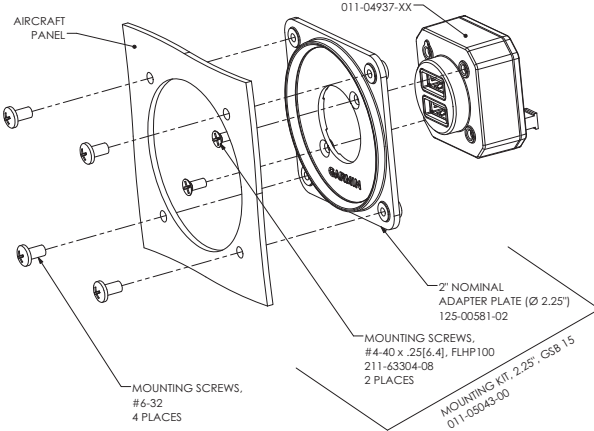

**GSB 15 (ALL CONFIGS) WITH 3.125\"/>**

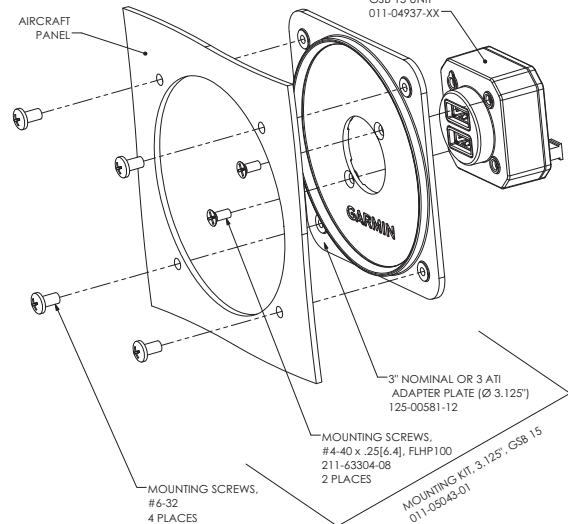

**Figure 2-1. GSB 15 Mounting Examples**

## 3 INSTALLATION PROCEDURE

### 3.1 Wiring Harness Installation

Allow adequate space for installation of cables and connectors. The installer shall supply and fabricate all of the cables. All electrical connections are made through a single connector.

[Section 6](#) defines the electrical characteristics of all input and output signals. Required connectors and associated hardware are provided in the connector kit ([Section 1.2.2](#)).



#### CAUTION

*For GSB 15 Type-A and Type-C (011-04937-20, -30) and GSB 15 Dual Type-C (011-04937-40, -50) units, use 7.5A breaker for 14VDC input per [Figure B-1](#).*



#### CAUTION

*See [Figure B-1](#) for power and power ground wire info.*



#### CAUTION

*Do not apply power to the unit until after the rear connector is completely seated. Connecting the unit while power is applied may cause damage to the device, and to other LRUs that are connected to the data lines.*



#### NOTE

*For data transfer installations, the ring terminal is required. If used, torque the ring terminal screw to 4-6 lbf-in.*

### 3.2 Equipment Mounting

For final installation and assembly, refer to the outline and installation drawings shown in [Appendix A](#) of this manual.

1. Assemble connector per instructions in [Section 2](#).
2. Install the unit from the back side of the desired installation surface with the circular surface protruding through the hole.
3. Attach the unit to the installation surface using a minimum of two screws (oriented diagonally). Rotational orientation of the unit within the mounting location is at the installer's discretion. The recommended screw torque is 6-8 lbf-in.
4. Attach the cable harness to the connector, paying attention to the keying and latching features of the connector.
5. If using mounting kit 011-05043-00 or 011-05043-01, mount adapter plate to desired mounting surface using specified screws (see [Figure A-4](#)) and attach unit to adapter plate using included screws.



#### CAUTION

*Be careful to not damage the unit or connector during installation. Avoid over-torquing mounting screws.*

#### 3.2.1 Unit Replacement

Make sure that power is removed before disconnecting the GSB 15.

### 3.3 Decorative Cover Installation



#### NOTE

*If using the Unfinished version of the Decorative Cover, finishing methods that require less than 120° C are recommended. If the finishing method (such as powder coating) exceeds 120° C, it is recommended to pre-heat the cosmetic piece to 200° C or greater before applying a finish in order to prevent cosmetic defects.*

Perform the following steps to install the Decorative Cover Kits listed in [Table 1-8](#) and [Table 1-9](#).

1. Prepare panel for installation. See Appendix A for details.
2. Install the Intermediate Piece using the two provided screws.
3. Peel off the tape liners from the Intermediate Piece.
4. Install the Cosmetic Piece.



#### NOTE

*For best results, install the Decorative Cover as specified below:*

- *Recommended installation temperature: 70-100°F (21-38°C)*
- *Minimum installation temperature: 50°F (10°C)*
- *Recommended screw torque: 4-6 lbf-in*
- *After removing the tape liners from the Intermediate Piece (Step 3 above), avoid touching the exposed adhesive.*
- *Before installing (Step 4 above), clean the inside of the Cosmetic Piece with a 50-90% isopropyl alcohol and water mixture. Allow it to fully dry before proceeding.*
- *When installing the Decorative Cover, apply an evenly distributed minimum force of 7 lbf (3 kgf or 30 N).*
- *The adhesive will fully cure within 72 hours (90% strength after 24 hours).*

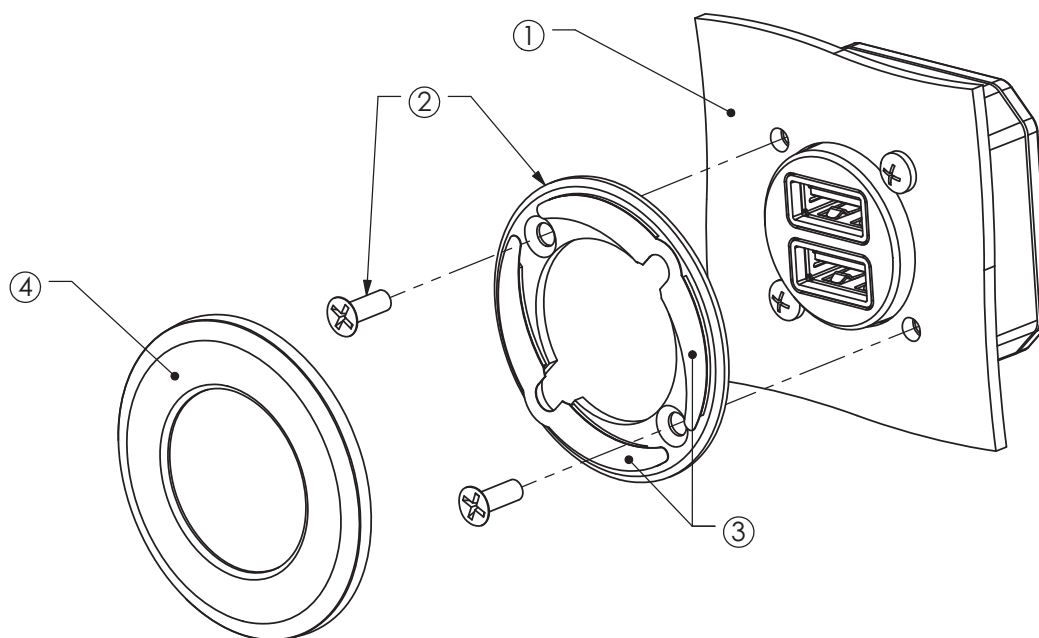

**Figure 3-1 GSB 15 Decorative Cover Installation**

## 4 POST INSTALLATION CONFIGURATION & CHECKOUT

### 4.1 Mounting, Wiring, and Power Checks

Verify all cables are properly secured and shields are connected to the ground lug located on the back of the unit. Check the movement of the flight and engine controls to verify there is no interference between the cabling and control systems. Verify all wiring is installed as described in this manual. Prior to installing and powering up the GSB 15, the wiring harness must be checked for proper connections to the aircraft systems and other avionics equipment. Point to Point continuity must be checked to expose any faults such as shorting to ground or wiring discrepancies. Any faults or discrepancies must be corrected before proceeding. After accomplishing a continuity check, perform power and ground checks to verify proper power distribution to the GSB 15. Any faults or discrepancies must be corrected at this time. The GSB 15 can be installed after completion of the continuity and power checks.



#### **CAUTION**

*For GSB 15 Type-A and Type-C (011-04937-20, -30) and GSB 15 Dual Type-C (011-04937-40, -50) unit installations in 14V aircraft confirm alternator voltage is 13.75V nominal. If lower, either adjust to 13.75V nominal or use shorter wire length than what is defined in [Figure B-1](#).*

### 4.2 Configuration Setup

Not applicable.

### 4.3 Diagnostic Information

Not applicable.

### 4.4 Ground Checks

Not applicable.

### 4.5 Software Loading Procedure

The GSB 15 does not load its own operating software.

## **5 CONTINUED AIRWORTHINESS**

Maintenance of the GSB 15 is “on condition” only.

## 6 CONNECTOR PINOUT INFORMATION

### 6.1 Pin Function List

#### 6.1.1 P201/202 Connector



**NOTE**

*P201 is the designation for the rear connector for GSB 15 part number 011-04937-00, -20, -40.*



**NOTE**

*P202 is the designation for the side connector for GSB 15 part number 011-04937-01, -30, -50.*

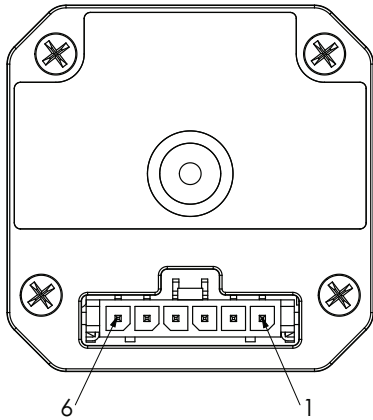

P201, GSB 15 Rear (011-04937-00, -20, -40) Unit

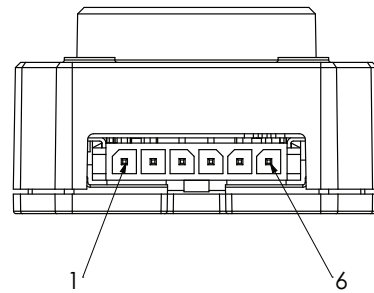

P202, GSB 15 Side (011-04937-01, -30, -50) Unit

**Figure 6-1. Unit View of P201/P202.**

**Table 6-1 J201/J202 Connector**

Pin	Pin Name	I/O	COMMENTS
1	AIRCRAFT POWER	IN	14V/28V Aircraft Power Input
2	USB DN	I/O	May use shielded CAT-5 ethernet cable.
3	USB DP	I/O	May use shielded CAT-5 ethernet cable.
4	USB GND	--	May use shielded CAT-5 ethernet cable.
5	BACKLIGHT ENABLE	IN	Do not connect for backlight ON (nighttime visibility). Ground connection for backlight OFF. 011-04937-20, -30, -40, -50 only: Dimmable input from GND (backlight OFF) to AIRCRAFT POWER (maximum brightness).
6	POWER GROUND	--	Ground

APPENDIX A OUTLINE AND INSTALLATION DRAWINGS

REAR CONNECTOR (-00/-20/-40 CONFIG), UNIT ONLY  
(-00 CONFIG SHOWN)

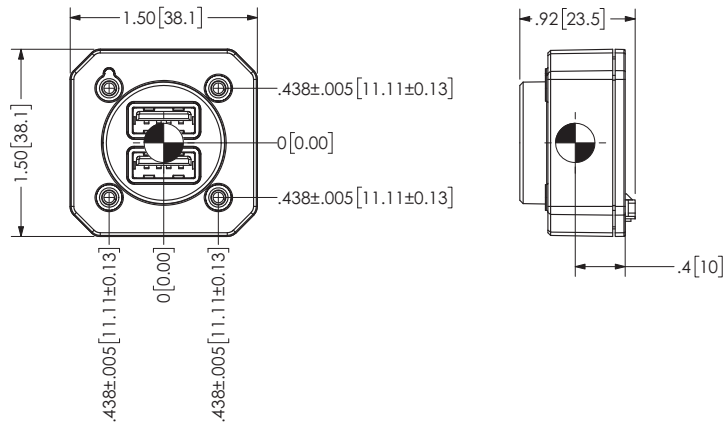

SIDE CONNECTOR (-01/-30/-50 CONFIG), UNIT ONLY  
(-01 CONFIG SHOWN)

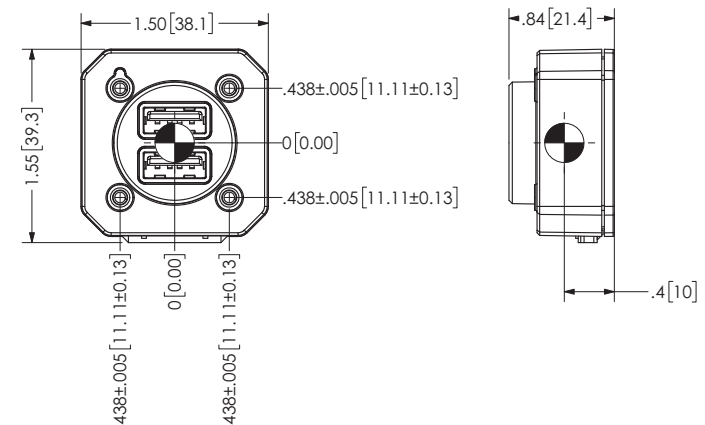

REAR CONNECTOR (-00/-20/-40 CONFIG), WITH CONNECTOR KIT (011-05044-00)  
(-00 CONFIG SHOWN)

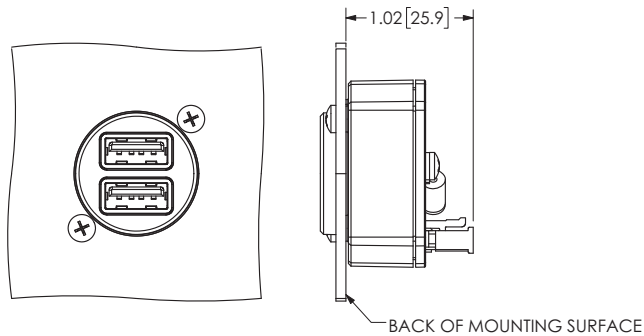

SIDE CONNECTOR (-01/-30/-50 CONFIG), WITH CONNECTOR KIT (011-05044-00)  
(-01 CONFIG SHOWN)

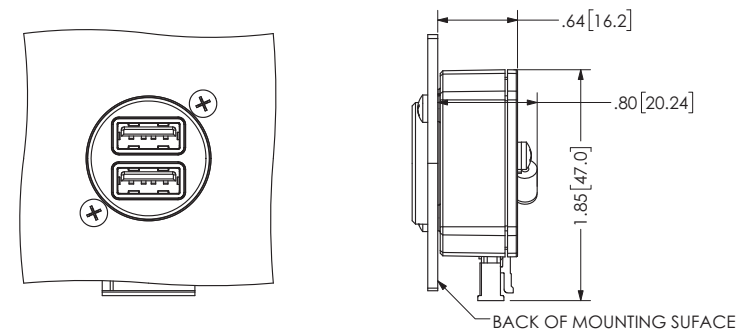

- NOTES:
1. DIMENSIONS: INCHES[mm]. METRIC VALUES ARE FOR REFERENCE ONLY.
  2. DIMENSIONS ARE NOMINAL AND TOLERANCES ARE NOT IMPLIED UNLESS SPECIFICALLY STATED.

Figure A-1 GSB 15 Outline Drawing



REAR CONNECTOR (-00/-20/-40 CONFIG) WITH CONNECTOR KIT (011-05044-00)

-00 Config Shown

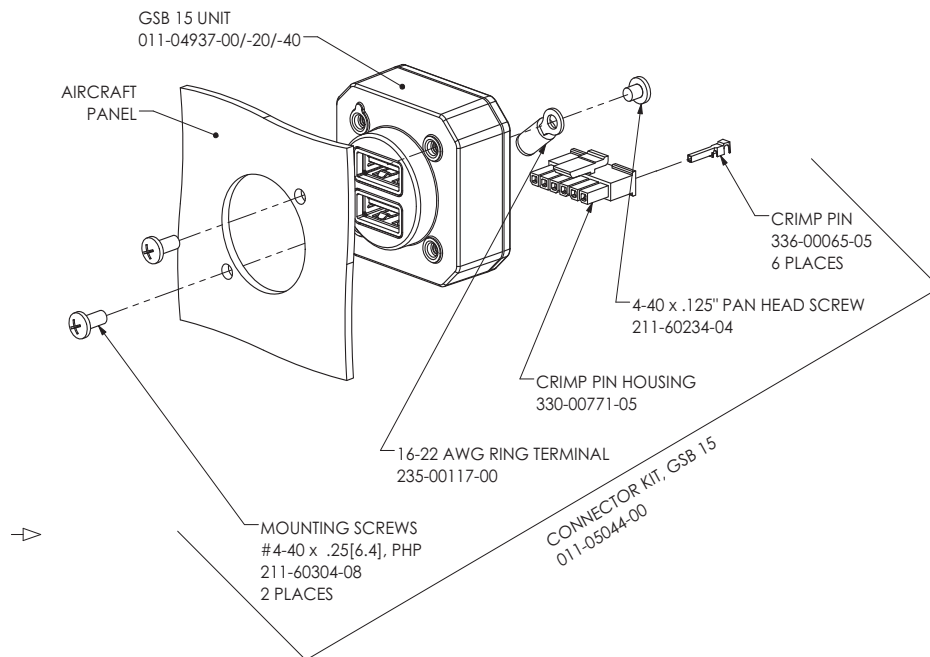

SIDE CONNECTOR (-01/-30/-50 CONFIG) WITH CONNECTOR KIT (011-05044-00)

-01 Config Shown

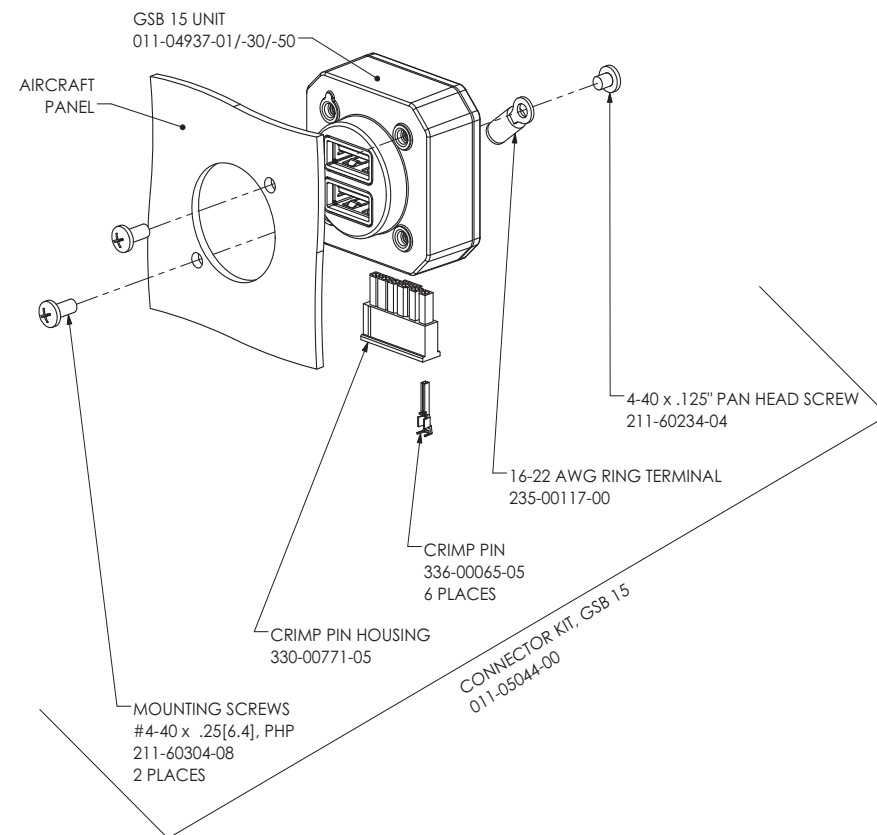

Panel Thickness	Recommended Screw Length	Included in Connector Kit (011-05044-00)?
.000-.050[0.00-1.27]	.188[4.76]	No
.050-.125[1.27-3.18]	.250[6.35]	Yes, Qty. 2
.125-.188[3.18-4.76]	.313[7.95]	No

**Figure A-2 GSB 15 Installation Drawing (011-05044-00 Mounting Kit)**

RECOMMENDED PANEL CUTOUT DIMENSIONS FOR UNIT

STANDARD HOLES  
(FOR PAN HEAD SCREWS)

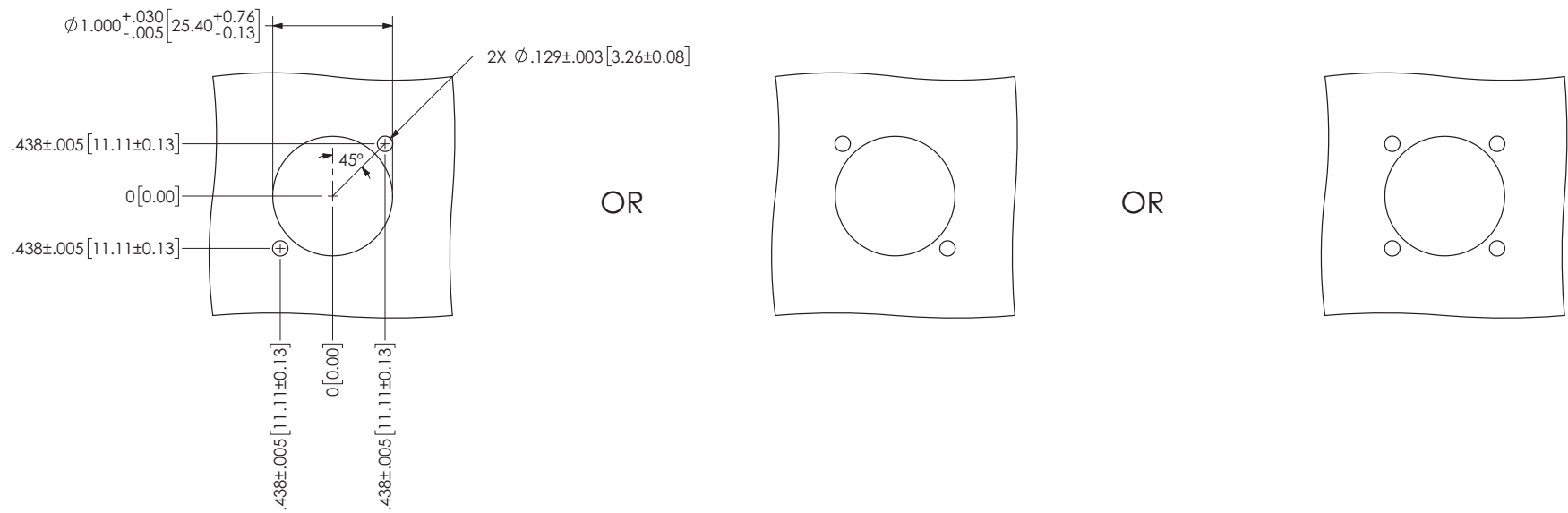

COUNTERSUNK HOLES  
(FOR 100° FLAT HEAD SCREWS)

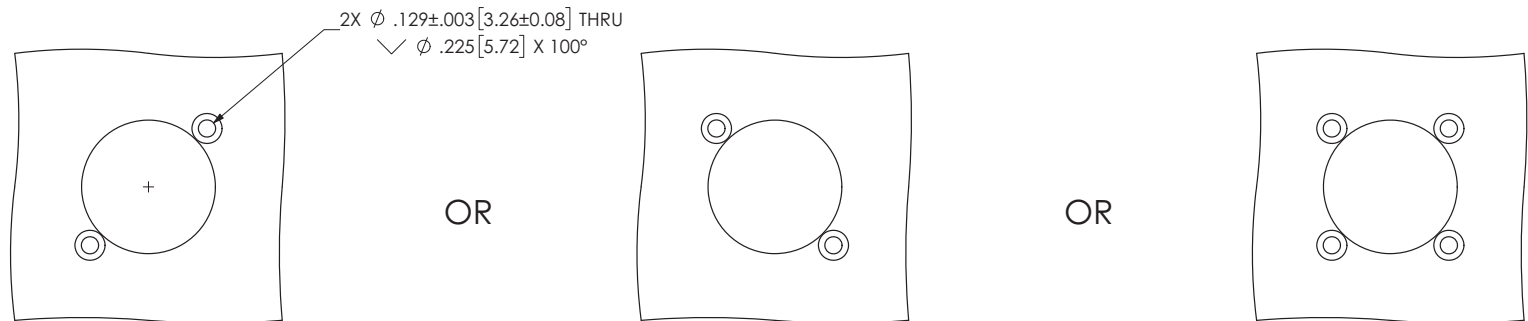
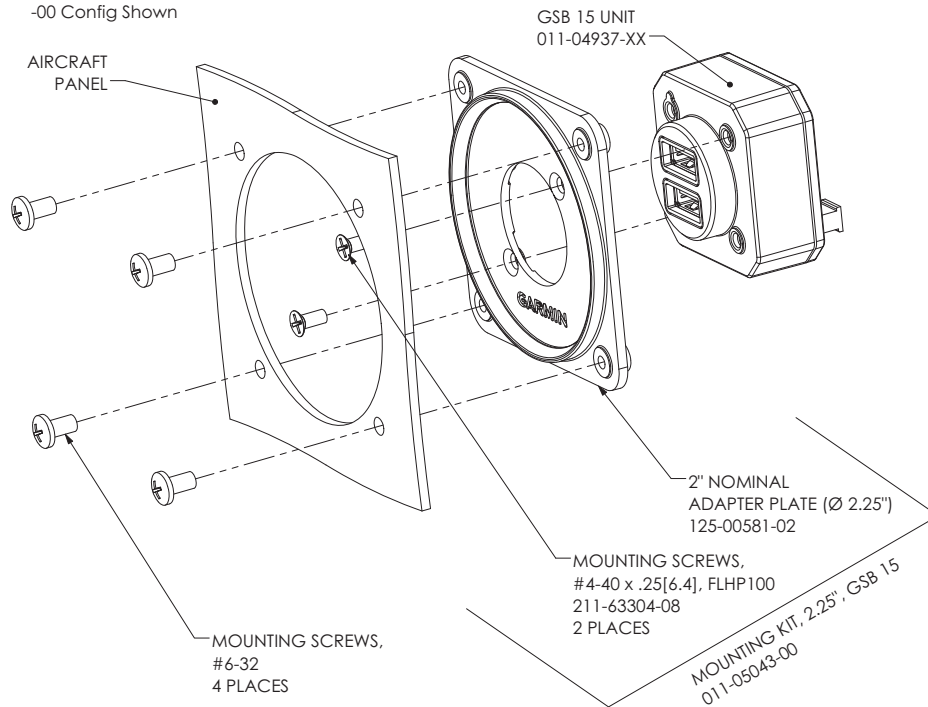

Figure A-3 GSB 15 Panel Cutout Drawing (Pan Head and Flat Head Screws)

**GSB 15 (ALL CONFIGS) WITH 2.25" MOUNTING KIT (011-05043-00)**

-00 Config Shown



Panel Thickness	Recommended Screw Length
.000-.050[0.00-1.27]	.188[4.76] Minimum
.050-.125[1.27-3.18]	.250[6.35] Minimum
.125-.188[3.18-4.76]	.313[7.95] Minimum

**GSB 15 (ALL CONFIGS) WITH 3.125" MOUNTING KIT (011-05043-01)**

-00 Config Shown

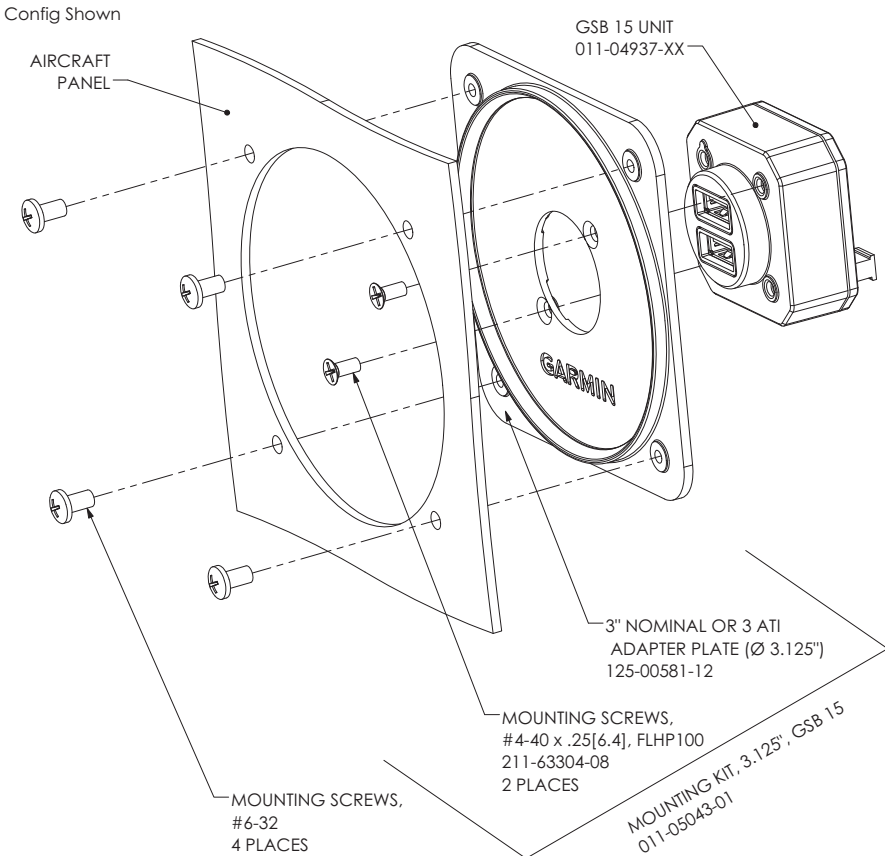

Panel Thickness	Recommended Screw Length
.000-.050[0.00-1.27]	.188[4.76] Minimum
.050-.125[1.27-3.18]	.250[6.35] Minimum
.125-.188[3.18-4.76]	.313[7.95] Minimum

**Figure A-4 GSB 15 Assembly Drawing (011-05043-00 and -01 Mounting Kits)**

**RECOMMENDED PANEL CUTOUT DIMENSIONS FOR UNIT WITH MOUNTING KIT**

011-05043-00 STANDARD HOLES (FOR PAN HEAD SCREWS)

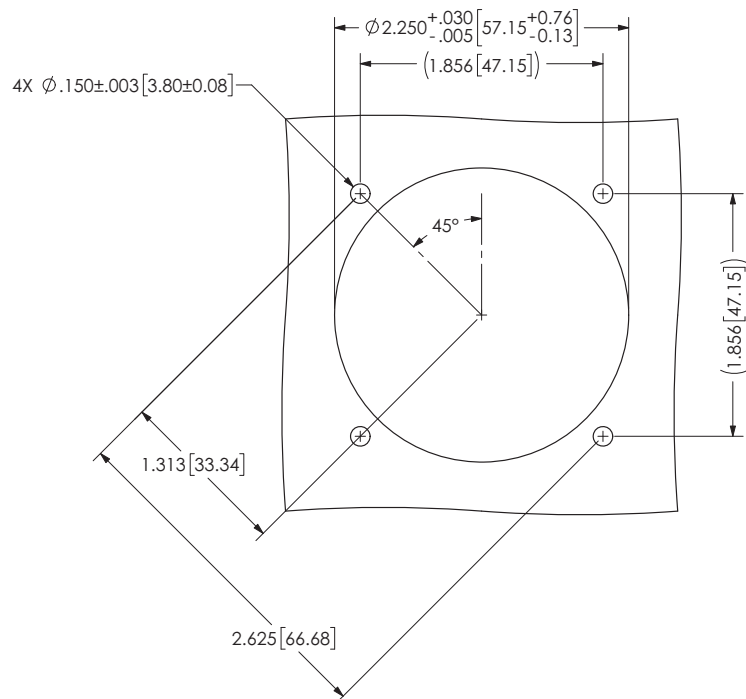

011-05043-01 STANDARD HOLES (FOR PAN HEAD SCREWS)

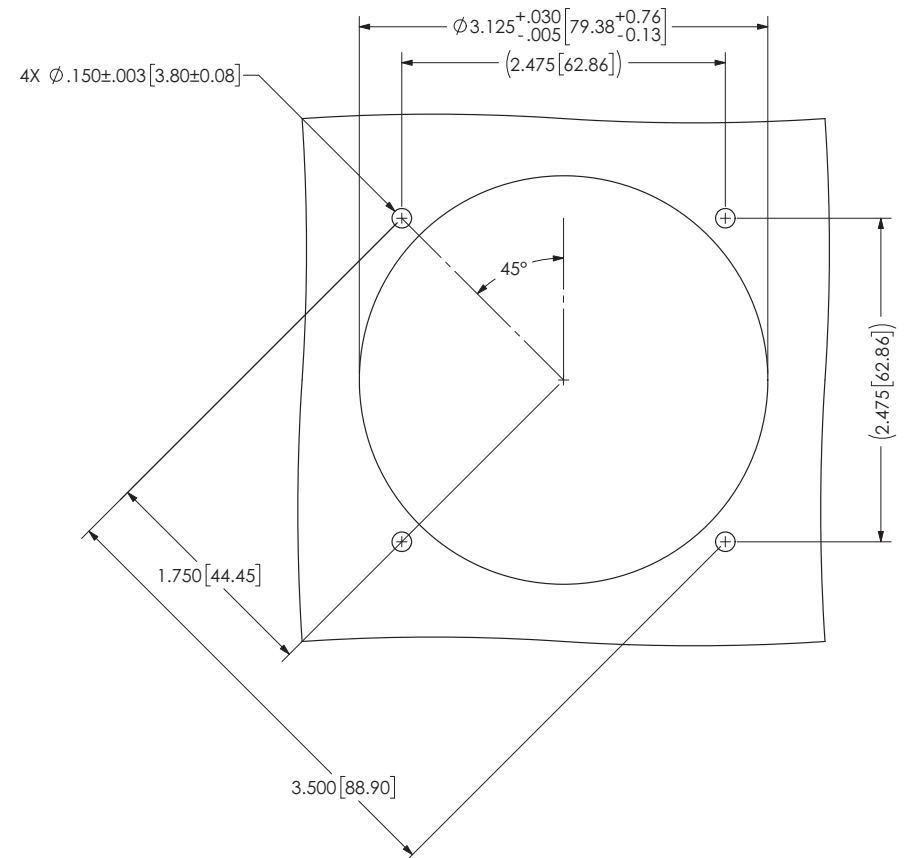
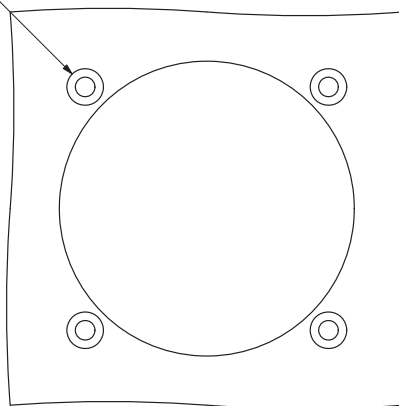

**Figure A-5 GSB 15 Panel Cutout Drawing w/Pan Head Screws (011-05043-00 and -01 Mounting Kits)**

RECOMMENDED PANEL CUTOUT DIMENSIONS FOR UNIT WITH MOUNTING KIT

011-05043-00 COUNTERSUNK HOLES (FOR 100° FLAT HEAD SCREWS)

4X  $\phi$  .150[3.80] THRU ALL  
 $\surd$   $\phi$  .279[7.09] X 100°



011-05043-01 COUNTERSUNK HOLES (FOR 100° FLAT HEAD SCREWS)

4X  $\phi$  .150[3.80] THRU ALL  
 $\surd$   $\phi$  .279[7.09] X 100°

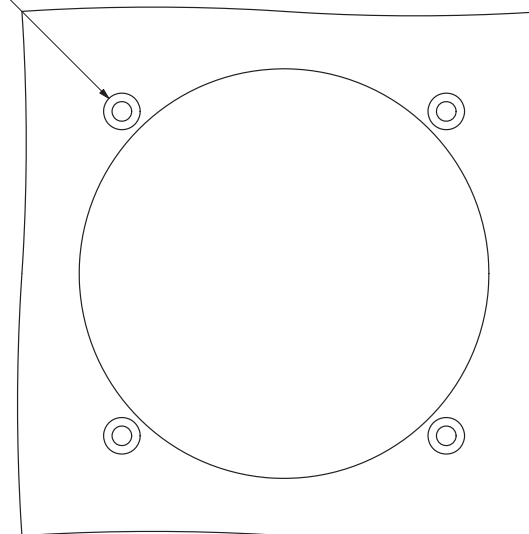
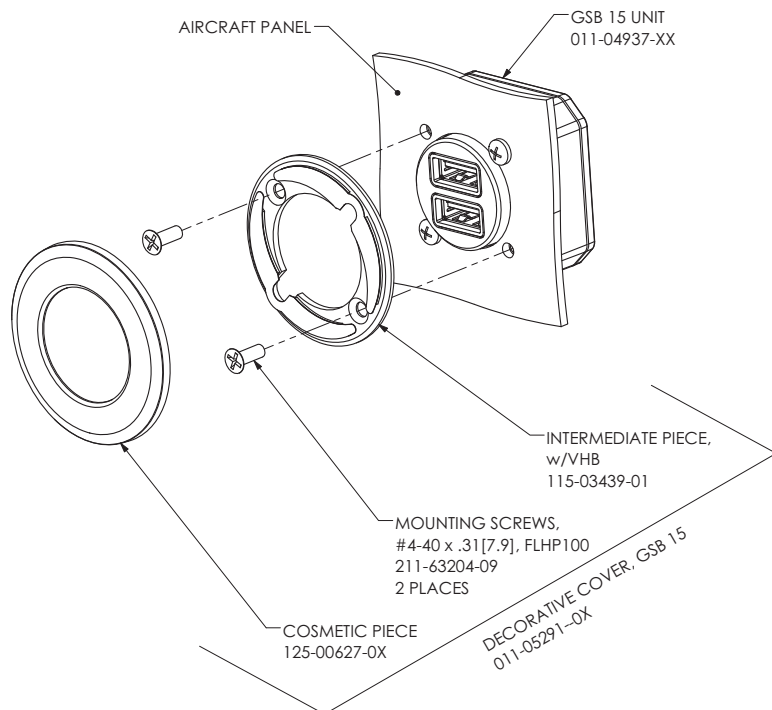

Figure A-6 GSB 15 Panel Cutout Drawing w/Flat Head Screws (011-05043-00 and -01 Mounting Kits)

**GSB 15 (ALL CONFIGS) WITH DECORATIVE COVER (011-05291-0X)**  
 -01 Config Shown



**COSMETIC PIECE IS AVAILABLE IN TWO FINISHES:**

PART NUMBER	FINISH
011-05291-00	CHROMATE CONVERSION COATING ("UNFINISHED")
011-05291-01	BLACK POWDER COAT

**COSMETIC PIECE WILL MOUNT FLUSH WITH UNIT ON A .08[2.0] THICK PANEL.**

**RECOMMENDED PANEL CUTOUT DIMENSIONS FOR UNIT WITH DECORATIVE COVER**

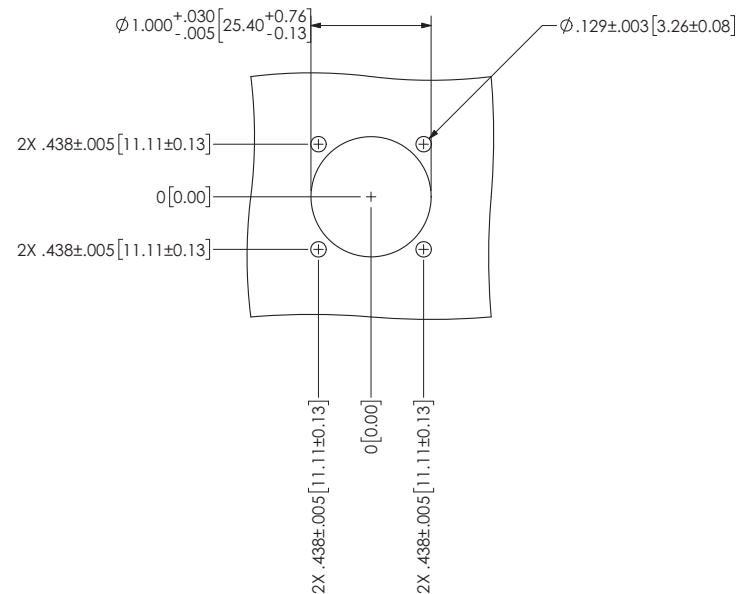

**Figure A-7 GSB 15 w/Decorative Cover Assembly and Panel Cutout Drawing**

PRINTABLE CUTOUT TEMPLATE FOR GSB 15 INSTALLATION (SCALE 1:1)

NEW INSTALLATIONS WITH 2 MOUNTING SCREWS

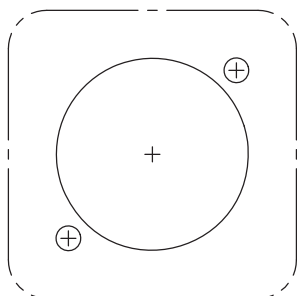

NEW INSTALLATIONS WITH 4 MOUNTING SCREWS

OR

NEW INSTALLATIONS WITH DECORATIVE COVER

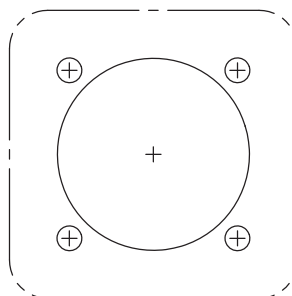

EXISTING INSTALLATIONS ADDING A DECORATIVE COVER

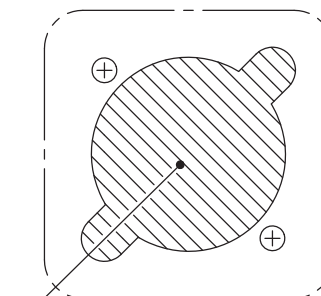

CUT AWAY HATCHED AREA

IMPORTANT!

Ensure the Page Scaling setting is set to "NONE" when printing this page. Verify dimensions (Page A-3 or A-7) of printed template are accurate before cutting panel.

Figure A-8 GSB 15 Panel Cutout Drawings, Actual Size

## APPENDIX B INTERCONNECT DRAWINGS

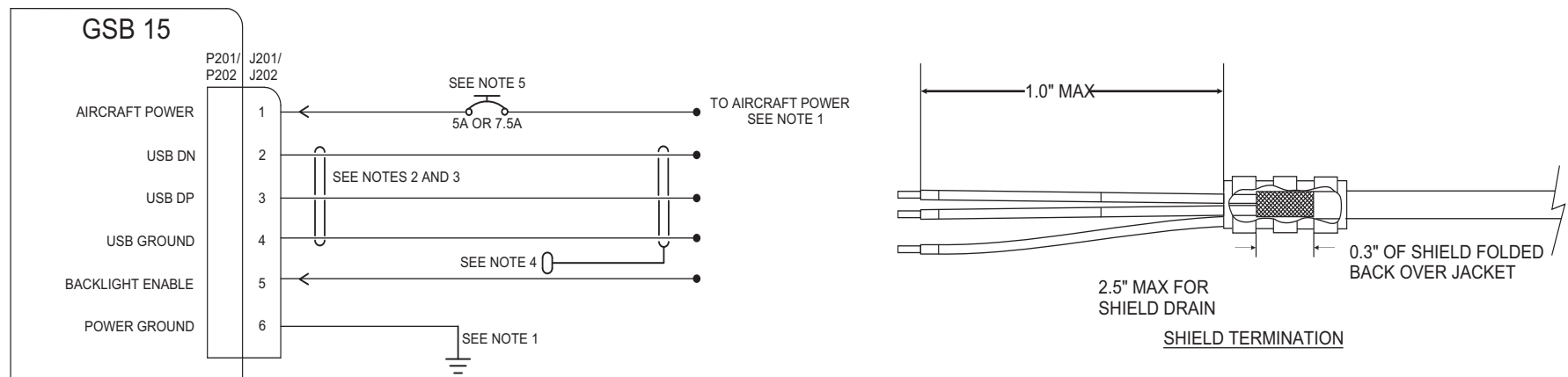

### NOTES:

1. CAUTION!

- A) GSB 15 DUAL TYPE-A (011-04937-00, -01) UNITS USE 20 OR 22 AWG FOR POWER AND POWER GROUND WIRES, 25 FT MAX.
  - B) GSB 15 TYPE-A AND TYPE-C (011-04937-20, -30) AND GSB 15 DUAL TYPE-C (011-04937-40, -50) UNITS INSTALLED IN 28V AIRCRAFT, USE 20 OR 22 AWG FOR AIRCRAFT POWER AND POWER GROUND WIRES, 25FT MAX.
  - C) GSB 15 TYPE-A AND TYPE-C (011-04937-20, -30) AND GSB 15 DUAL TYPE-C (011-04937-40, -50) UNITS INSTALLED IN 14V AIRCRAFT, USE 20 AWG FOR AIRCRAFT POWER AND POWER GROUND WIRES, 8FT MAX.
- \*) IF LONGER WIRE LENGTH IS NEEDED, USE 16 AWG FOR POWER AND POWER GROUND WIRES, 13FT MAX, SPLICED TO 2FT MAX 20 AWG POWER AND POWER GROUND WIRES AT GSB 15 CONNECTOR. USE M81824/1-2 (OR EQUIVALENT) SPLICES.

2. USE CAT 5 SHIELDED TWISTED PAIR WIRING, 10 FT MAX.

3. CONNECT TO CAT 5 SHIELD USING M83519 SOLDER SLEEVE (OR EQUIVALENT) 1" [2.54 cm] MAX FROM CONNECTOR. SOLDER SLEEVES WITH PRE-INSTALLED LEADS ARE ACCEPTABLE.

4. TERMINATE CAT 5 SHIELD TO THE BACK OF THE GSB 15 USING THE RING TERMINAL AND RING TERMINAL SCREW (P/N 235-00117-00 AND 211-60234-04).

5. CAUTION! FOR GSB 15 TYPE-A AND TYPE-C (011-04937-20, -30) AND GSB 15 DUAL TYPE-C (011-04937-40, -50) UNITS, USE 7.5A BREAKER FOR 14VDC INPUT. GSB 15 DUAL TYPE-A (011-04937-00, -01) USE 5A BREAKER FOR 14VDC INPUT. ALL GSB 15 MODELS USE 5A BREAKER FOR 28VDC INPUT.

6. SYMBOL DESIGNATIONS:

AIRCRAFT GROUND

TWISTED SHIELDED PAIR

**Figure B-1 GSB 15 Example Interconnect**



**GARMIN**  **®**