



Garmin G5

Electronic Flight Instrument Part 23 AML STC Installation Manual





©2016, 2017 Garmin International or its subsidiaries
All Rights Reserved

Except as expressly provided herein, no part of this manual may be reproduced, copied, transmitted, disseminated, downloaded or stored in any storage medium, for any purpose without the express prior written consent of Garmin. Garmin hereby grants permission to download a single copy of this manual and of any revision to this manual onto a hard drive or other electronic storage medium to be viewed and to print one copy of this manual or of any revision hereto, provided such electronic or printed copy of this manual or revision must contain the complete text of this copyright notice and provided further any unauthorized commercial distribution of this manual or any revision hereto is strictly prohibited.

Garmin®, flyGarmin®, are registered trademarks of Garmin International or its subsidiaries. G5™ trademark of Garmin International or its subsidiaries. These trademarks may not be used without the express permission of Garmin.

Garmin International, Inc
1200 E. 151st Street Olathe, KS 66062 USA
Telephone: 913-397-8200
Technical Support and Field Service Engineers: 888.606.5482
www.flyGarmin.com

Garmin (Europe) Ltd.
Liberty House
Bull Copse Road
Hounslow Business Park
Southampton, SO40 9LR, UK
Telephone: +44 (0) 23 8052 4000
Fax: +44 (0) 23 8052 4004

Garmin AT, Inc.
2345 Turner Rd. SE
Salem, OR 97302 USA
Telephone: 503.581.8101



RECORD OF REVISIONS

Revision	Revision Date	Description
1	07-14-2016	Initial Release
2	07-21-2016	Revised to incorporate comments and changes driven by document reviews.
3	08-08-2016	Removed shock mount installation limitation in section 2.1, removed shock mount replacement instructions in section 4.1 and added engine run up details in section 5.3.7.2.
4	01-05-2017	Updated Section 1.5 to show software P/N 006-B2304-02, revised section 3.4.1 to add clarification on GPS receiver configuration, updated Table 5-1 to add clarification on GPS receiver configuration.
5	03-07-2017	Revised to add G5 DG/HSI, supporting equipment and associated functions.
6	04-26-2017	Updated GAD 29 and GMU 11 Part Numbers
7	06-20-2017	Updated GMU 11 & GAD 29 Dimensions and EMI Test Harness
8	10/14/2017	Revised to cover changes associated with the addition of the G5/GAD 29B third party autopilot interfaces.
9	10/26/2017	Update third party autopilot configurations and minor typographical corrections.
10	11/02/2017	Corrected Cessna Third Party autopilot model coverage and minor wiring typographical fixes.

This area intentionally blank



INFORMATION SUBJECT TO EXPORT CONTROL LAWS

This document may contain information which is subject to the Export Administration Regulations (“EAR”) issued by the United States Department of Commerce (15 CFR, Chapter VII, Subchapter C) and which may not be exported, released, or disclosed to foreign nationals inside or outside of the United States without first obtaining an export license. A violation of the EAR may be subject to a penalty of up to 10 years imprisonment and a fine of up to \$1,000,000 under Section 2410 of the Export Administration Act of 1979. Include this notice with any reproduced portion of this document.

DEFINITIONS OF WARNINGS, CAUTIONS, AND NOTES



WARNING

Warnings are used to bring to the installer's immediate attention not only damage to the equipment but personal injury may occur if the instruction is disregarded.



CAUTION

Cautions are used to alert the individual damage to equipment may result if the procedural step is not followed to the letter.



NOTE

Notes are used to expand and explain the preceding step and provide further understanding of the reason for the particular operation.

This area intentionally blank



WARNING

This product, its packaging, and its components contain chemicals known to the State of California to cause cancer, birth defects, or reproductive harm. This notice is being provided in accordance with California's Proposition 65. If you have any questions or would like additional information, please refer to our web site at www.garmin.com/prop65.



WARNING

Perchlorate Material – special handling may apply, See www.dtsc.ca.gov/hazardouswaste/perchlorate.



BATTERY WARNINGS:

If these guidelines are not followed, the lithium-ion battery may experience a shortened life span or may present a risk of damage to the device, fire, chemical burn, electrolyte leak, and/or injury.

Do not leave the battery exposed to a heat source or in a high temperature environment. To help prevent damage, store the battery out of direct sunlight.

For maximum battery longevity, store within a temperature range of 32° to 77°F (from 0° to 25°C).

Do not use a sharp object to remove the battery.

Do not disassemble, puncture, damage, or incinerate the device or battery.

Keep the battery away from children.

Only replace the battery with the approved replacement from Garmin. Using another battery presents a risk of fire or explosion. To purchase a replacement battery, see you Garmin dealer or the Garmin website.

Contact your local waste disposal department to dispose of the device and battery in accordance with applicable local laws and regulations.



CAUTION:

*The display uses a lens with a special coating that may be sensitive to skin oils, waxes, and abrasive cleaners. **CLEANERS CONTAINING AMMONIA WILL HARM THE ANTI-REFLECTIVE COATING.** It is very important to clean the lens using a clean, lint-free cloth and a cleaner that is specified as safe for anti-reflective coatings. Avoid any chemical cleaners or solvents that can damage plastic components.*



CAUTION:

The G5 does not contain any user-serviceable parts. Repairs should only be made by an authorized Garmin service center. Unauthorized repairs or modifications could result in permanent damage to the equipment and void both the warranty and the authority to operate this device under FAA, FCC, and other applicable regulations.



NOTE:

Use of polarized eyewear may cause the display to appear dim or blank.



NOTE

All screen shots used in this document are current at the time of publication. Screen shots are intended to provide visual reference only. All information depicted in screen shots, including software file names, versions, and part numbers, is subject to change and may not be up to date.

This area intentionally blank



TABLE OF CONTENTS

<u>SECTION</u>	<u>PAGE</u>
1 GENERAL DESCRIPTION	12
1.1 Introduction	12
1.2 Acronyms and Abbreviations	12
1.3 Reference Documents	13
1.4 STC Permission	13
1.5 Scope	13
1.6 System Overview	14
1.7 Technical Specifications	21
2 LIMITATIONS	22
2.1 Installation Limitations	22
2.2 Operational Limitations	23
3 INSTALLATION OVERVIEW	24
3.1 Introduction	24
3.2 Installation Materials	24
3.3 Test Equipment	27
3.4 Installation Considerations	27
4 INSTALLATION PROCEDURES	34
4.1 Mechanical Installation	34
4.2 Antenna Cable Installation and Connections	64
4.3 Electrical Installation	65
4.4 Weight and Balance	72
4.5 Electrical Load Analysis	72
4.6 Electrical Bonding	80
5 SYSTEM INTERCONNECTS	86
5.1 G5 Interconnect Notes	87
5.2 Power and Ground	88
5.3 G5 (Attitude Indicator) with External GPS Antenna	89
5.4 G5 (Attitude Indicator) with GPS Position Input	91
5.5 G5 (Attitude Indicator) and GMU 11 with GPS Position Input	94
5.6 G5 (Attitude Indicator or DG), GMU 11 and GPS Antenna	97
5.7 G5 (HSI) with VHF Navigator	100
5.8 G5 (HSI) with GPS/VHF Navigator	103
5.9 Dual G5 without Navigator	108
5.10 Dual G5 with VHF Navigator	111
5.11 Dual G5 with GPS/VHF Navigator	115
5.12 GAD 29B Interface to Third-Party Autopilots	121
6 SYSTEM CONFIGURATION AND CHECKOUT PROCEDURES	132
6.1 Overview	132
6.2 Mounting, Wiring, and Power Checks	132
6.3 Post-Installation Checkout Procedures	132
6.4 Documentation Checks	154

FIGURES

Figure	Page
Figure 1-1, G5 Electronic Flight Instrument (Attitude)	15
Figure 1-2 G5 Standby Battery	16
Figure 1-3 G5 Electronic Flight Instrument (DG/HSI)	18
Figure 1-4 GMU 11	20
Figure 1-5 GAD 29/29B.....	21
Figure 3-1 CAN Bus Backbone	30
Figure 3-2 Correct CAN BUS Wiring Example and Node Connections.....	30
Figure 3-3 Incorrect CAN Wiring Example.....	31
Figure 3-4 CAN Bus Termination (011-02887-00) for G5 and GMU 11	31
Figure 3-5 CAN Bus Termination for GAD 29/29B	31
Figure 4-1 Typical G5 Installations for IFR Approved Aircraft	35
Figure 4-2 G5 Mounting Ring.....	36
Figure 4-3 Maximum Misalignment of the G5 in the Lateral Axis	36
Figure 4-4 Maximum Misalignment of the G5 in the Longitudinal Axis.....	37
Figure 4-5 Maximum Misalignment of the G5 in the Vertical Axis	37
Figure 4-6 G5 Alignment Pin.....	38
Figure 4-7 G5 Hex Driver Insertion	38
Figure 4-8 G5 Captive Mounting Screw Replacement	39
Figure 4-9 Required Vertical Spacing Between G5 Units.....	40
Figure 4-10 Instrument Panel Modification	40
Figure 4-11 G5 Adapter Plate	41
Figure 4-12 G5 Adapter Plate Assembly	41
Figure 4-13, G5 Instrument Hole Dimensions.....	42
Figure 4-14, Clearance for Connections	43
Figure 4-15 Recessed Adapter Plate.....	43
Figure 4-16 Recessed Adapter Plate Template Reference Holes.....	44
Figure 4-17 Single G5 Recessed Adapter Plate Installation.....	45
Figure 4-18 Single G5 Recessed Installation.....	45
Figure 4-19 Dual Vertical G5 Recessed Adapter Plate Installation	46
Figure 4-20 Dual Vertical G5 Recessed Installation	46
Figure 4-21 Dual Horizontal G5 Recessed Installation	47
Figure 4-22, Instrument Panel Limitations	48
Figure 4-23 Instrument Panel; View looking forward	49
Figure 4-24 Instrument Panel view with instruments removed	49
Figure 4-25 Recessed Adapter Plate located on panel	50

Figure 4-26 Match drilling through panel, using adapter plate as template 50

Figure 4-27 Preliminary trimming of adapter plate 51

Figure 4-28 Adapter plate located on far side of instrument panel 51

Figure 4-29 Additional trimming of adapter plate required 52

Figure 4-30 Trimmed adapter plate 52

Figure 4-31 Adapter plate mounting holes 53

Figure 4-32 Dual G5 panel cutout, using match drilled holes for reference 53

Figure 4-33 Instrument panel after cutout for dual vertical G5 units 54

Figure 4-34 Adapter plate installed 54

Figure 4-35 Dual vertical G5 units installed 55

Figure 4-36 G5 flush mount adapter plate printable template 56

Figure 4-37 GMU 11 Pitch and Roll Requirements 58

Figure 4-38 GMU 11 Heading Alignment Requirements 59

Figure 4-39 GMU 11 Mounting Hardware 60

Figure 4-40 GAD 29/29B Mounting Hardware 62

Figure 4-41 GAD 29B Inline Transformer Mounting Instructions 62

Figure 4-42 Wiring Harness Connector Assembly 69

Figure 4-43 Shield Termination Methods 70

Figure 4-44 Ammeter Placement for Current Measurements 75

Figure 4-45 Blank Electrical Load Tabulation Form, Sheet 1 of 2 77

Figure 4-46 Blank Electrical Load Tabulation Form, Sheet 2 of 2 78

Figure 4-47 Sample Completed Electrical Load Tabulation Form, Sheet 1 of 2 79

Figure 4-48 Sample Completed Electrical Load Tabulation Form, Sheet 2 of 2 80

Figure 4-49 Fiberglass Insulation for Carbon Fiber Material 82

Figure 4-50 Aluminum Tape Joint 83

Figure 4-51 Aluminum Tape Ground Termination 84

Figure 4-52 GAD 29/29B Aluminum Tape Installation 84

Figure 5-1 G5 Interconnect Notes 87

Figure 5-2 Power and Ground 88

Figure 5-3 G5 (Attitude Indicator) with External GPS Antenna 89

Figure 5-4 G5 (Attitude Indicator) with GPS Position Input 91

Figure 5-5 G5 (Attitude Indicator) and GMU 11 with GPS Position Input 94

Figure 5-6 G5 (Attitude Indicator or DG), GMU 11 and GPS Antenna 97

Figure 5-7 G5 (HSI) with VHF Navigator 100

Figure 5-8 G5 (HSI) with GPS/VHF Navigator 103

Figure 5-9 G5 (HSI) with GPS/VHF Navigator Notes 104

Figure 5-10 Dual G5 without Navigator 108



Figure 5-11 Dual G5 with VHF Navigator	111
Figure 5-12 Dual G5 with GPS/VHF Navigator	115
Figure 5-13 Dual G5 with GPS/VHF Navigator Notes	116
Figure 5-14 GAD 29B Interface to Century Autopilots Sheet 1 of 2	122
Figure 5-15 GAD 29B Interface to Century Autopilots Sheet 2 of 2	123
Figure 5-16 GAD 29B Interface to Cessna Autopilots Sheet 1 of 2	125
Figure 5-17 GAD 29B Interface to Cessna Autopilots Sheet 2 of 2	125
Figure 5-18 GAD 29B Interface to Garmin Autopilots	127
Figure 5-19 GAD 29B Interface to Honeywell Autopilots	128
Figure 5-20 GAD 29B Interface to S-TEC Autopilots	130
Figure 6-1, Attitude Calibration Example	138
Figure 6-2, Example of Calibration Equations	138
Figure 6-3 Engine Vibration Test Failure Indication	140
Figure 6-4 Example EMC Source/Victim Matrix	151
Figure 6-5 J51 on the G5	156
Figure 6-6 J111 on the GMU 11	157
Figure 6-7 J291 on the GAD 29/29B	159
Figure 6-8 J292 on the GAD 29/29B	159
Figure 6-9 G5 Outline Drawing	162
Figure 6-10 G5 Installation Drawing	163
Figure 6-11 G5 Panel Cutout Measurements (Not to Scale)	164
Figure 6-12 GAD 29/29B Outline Drawing	165
Figure 6-13 GAD 29/29B Install Breakdown	166
Figure 6-14 GMU 11 Outline Drawing	167
Figure 6-15 GMU 11 Install Breakdown	168
Figure 6-16 Magnetic Interference Test Harness	170
Figure 6-17 GMU 11 Overbraid Installation	174
Figure 6-18 GMU 11 Overbraid Termination	175



TABLES

<u>Table</u>	<u>Page</u>
Table 1-1: Reference Documents	13
Table 1-2 G5 Attitude and G5 DG/HSI Equipment	14
Table 1-3: Physical Characteristics.....	21
Table 1-4: Power Requirements	22
Table 3-1: Contents of the G5 Installation Kit (011-03892-00)	24
Table 3-2: Contents of the GMU 11 Installation Kit (011-04349-90)	24
Table 3-3: Contents of the Connector Kit (011-03002-00).....	24
Table 3-4: Contents of the GAD 29/29B Connector Kit (011-03271-00)	25
Table 3-5: G5 Adapter Plate	25
Table 3-6: G5 Recessed Adapter Plate	25
Table 3-7 Supported Garmin Antennas	28
Table 3-8 Supported Non-Garmin Antennas	28
Table 3-9 GPS Antenna Minimum Requirements.....	28
Table 3-10: G5 and Supporting LRU Circuit Breaker Labels	29
Table 4-1 GMU 11 Supporting Hardware	58
Table 4-2 GAD 29/29B Supporting Hardware.....	61
Table 4-3: Contact Crimp Tooling	65
Table 4-4: G5 (1P51, 2P51) and GMU11 (P111) Connector Parts	66
Table 4-5: GAD 29/29B 9-pin (P291) Connector Parts.....	67
Table 4-6: GAD 29/29B 25-pin (P292) Connector Parts.....	68
Table 4-7: LRU Weights.....	72
Table 4-8: Sample Net Electrical Load Change Calculation.....	73
Table 5-1: Third-Party Autopilots	121
Table 6-1: Post-Installation Calibration Procedure Summary.....	136
Table 6-2: Heading Verification.....	143



1 GENERAL DESCRIPTION

1.1 Introduction

The G5 is an electronic instrument display capable of operating as a primary attitude indicator, backup attitude indicator with primary rate-of-turn indicator, DG or HSI. This STC approves the installation of the G5(s) in the existing instrument panel.

In the attitude application, the Garmin G5 indicator can replace an existing vacuum attitude indicator or rate-of-turn indicator. The G5 can also replace existing vacuum driven DGs or existing HSI's, either standalone or in combination with a G5 attitude display.

When installed as a DG/HSI, the G5 can interface with third party autopilots using the GAD 29B.

The G5 is designed to be installed into a standard 3 1/8" instrument hole in place of the existing indicators mentioned previously. The other primary flight instruments remain in the current approved locations. The G5 cannot replace an existing primary attitude indicator that has a Flight Director; however, if the existing attitude indicator is interfaced to the autopilot and it does not include a Flight Director, that existing attitude indicator can be moved to the rate-of-turn indicator location and the G5 installed as the primary attitude indicator.

Alternatively, for installations that do not install the G5 as a replacement primary attitude indicator, the G5 can be installed as a second attitude indicator in place of the existing rate-of-turn indicator. If the existing rate-of-turn indicator is interfaced with the autopilot, it cannot be replaced by a G5. The G5 can only be installed in the locations specified in this STC. It is the installer's responsibility to ensure the installation limitations are considered prior to modifying the aircraft.



NOTE

Throughout this document the term "rate-of-turn indicator" will be used and could be speaking to either a turn coordinator or turn and bank indicator. Typically these instruments are used to cross-check the attitude indicator and directional gyro for bank information. However, these instruments only provide information that the aircraft is in a turn and whether the turn is at the standard rate (a standard rate turn is 3 degrees per second, or 2 minutes for a full 360-degree circle). They do not provide information on the bank angle. Regardless of the specific instrument installed the G5 is capable of replacing either configuration of a turn coordinator or turn and bank indicator.

The software versions and information in this document are subject to change without notice. Visit www.Garmin.com and navigate to the Aviation Product/General Aviation/Indicators/G5 page for current updates and supplemental information concerning operation of the G5 attitude indicator.

1.2 Acronyms and Abbreviations

The following acronyms and abbreviations are used in this manual:

AFMS	Airplane Flight Manual Supplement	HSI	Horizontal Situation Indicator
ALT	Altitude (mode)	ICA	Instructions for Continued Airworthiness
AML	Approved Model List	I/O	Input/Output
CAN	Controller Area Network	LRU	Line Replaceable Unit
DG	Directional Gyro	STC	Supplemental Type Certificate



CFR Code of Federal Regulations
FAA Federal Aviation Administration
GPS Global Positioning System

TSO Technical Standard Order
WAAS Wide Area Augmentation System

1.3 Reference Documents

Table 1-1: Reference Documents

Title	Document Number
FAA Advisory Circular, Acceptable Methods, Techniques, and Practices – Aircraft Inspection and Repair	AC 43.13-1B
FAA Advisory Circular, Acceptable Methods, Techniques, and Practices – Aircraft Alterations	AC 43.13-2B
Aerospace Systems Electrical Bonding and Grounding for Electromagnetic Compatibility and Safety	SAE ARP1870
Standard Guide for Aircraft Electrical Load and Power Source Capacity Analysis	ASTM F 2490-05
GTN 6XX/7XX Install Manual	190-01007-A3
GNS 400W Series Installation Manual	190-00356-08
GNS 500W Series Installation Manual	190-00357-08
Garmin GPS and XM® Antenna STC Installation Manual	190-01284-00
Garmin G5 Electronic Flight Instrument Part 23 AML STC Maintenance Manual including Instructions for Continued Airworthiness	190-01112-11
Pilots Guide, Garmin G5 Electronic Flight Instrument, Part 23 AML STC	190-01112-12
Airplane Flight Manual Supplement Garmin G5 Electronic Flight Instrument Part 23 AML STC	190-01112-13

1.4 STC Permission

A permission letter to use this STC data is available for download for each authorized G5 installation. The STC Installation Kit contains instructions for downloading the STC permission letter from www.Garmin.com. Contact a local Garmin Dealer for G5 Attitude, G5 DG and G5 HSI STC Kit Part Numbers.

1.5 Scope

This manual applies to the modification of an aircraft listed on the Part 23 AML STC SA01818WI for the installation of equipment listed below. Only the interfaces between the Garmin G5 Electronic Flight Instrument and equipment listed in this manual are approved by the STC.



Table 1-2 G5 Attitude and G5 DG/HSI Equipment

Model	Nomenclature	Unit P/N	Catalog P/N	Software P/N and Version
G5	Electronic Flight Instrument	011-03809-00	010-01485-00	006-B2304-XX*
G5	Installation Kit	011-03892-00	010-12493-10	N/A
G5	Battery pack	011-03893-00	010-12493-00	N/A
GMU 11	Magnetometer	011-04349-01	010-01788-01	006-B2770-XX*
GMU 11	GMU 11 Installation Kit	011-04349-90	010-12598-00	N/A
GAD 29	Data Bus Converter	011-03236-01	010-01172-01	006-B1760-XX*
GAD 29B**	Data Bus Converter	011-03236-11	010-01172-10	006-B1760-XX*
GAD 29/29B	GAD 29/29B Connector Kit	011-03271-00	N/A	N/A

* The approved G5 Part 23 AML STC Electronic Flight Instrument software is P/N 006-B2304-XX. XX denotes the specific version P/N, i.e. 006-B2304-02 is software version 2.60. The G5 Electronic Instrument, GMU 11 Magnetometer and GAD 29/29B listed above is shipped with approved software. To verify the latest approved software visit www.Garmin.com and navigate to the Aviation /General Aviation/Flight Instruments & Indicators/G5 page. Select ‘Software’ in the overview tab.

** The GAD 29B is only required in installations that utilize the G5 heading and course output to a third party autopilot.

1.6 System Overview

1.6.1 G5 Attitude Indicator

The G5 Electronic Flight Instrument configured as an attitude indicator, is shown in Figure 1-1 . The G5 is an electronic instrument display operating as a standalone flight display. It features a bright, sunlight readable, 3.5-inch color display which is sized to fit in a standard 3-1/8-inch instrument cutout. The G5 contains integrated attitude/air data sensors that provide display of attitude and secondary display of air data information. The G5 has battery backup and in the case of aircraft power loss will sustain G5 operation with up to 4 hours of emergency power.

This area intentionally blank



Figure 1-1, G5 Electronic Flight Instrument (Attitude)

1.6.1.1 Attitude

The G5 calculates aircraft attitude using information from its built-in inertial sensors. If the G5 senses that the attitude solution is valid, but not yet within the internal accuracy limits, "ALIGNING" is displayed. The G5 can align itself both while taxiing and during level flight.

The G5 attitude functions are shown below:

- Pitch
- Roll

1.6.1.2 Turn Rate

The Turn Rate Indicator is located at the bottom of the display. A magenta Turn Rate Trend Vector shows the current turn rate. A standard-rate turn (3 deg/sec) is shown on the indicator by the trend vector stopping at the standard turn rate tick mark.

1.6.1.3 Slip/skid

The Attitude Indicator displays slip/skid information as indicated by the location of the ball at the lower center portion of the indicator.

1.6.1.4 GPS Aiding

The G5 requires GPS for attitude aiding. It contains an internal GPS receiver that can be connected to an external antenna or optionally can use external GPS input if available.

As installed in this STC, the G5 receives the GPS position for aiding via the following methods:

- Previously installed and approved GPS antenna (See Section 3.4.1)
- GTN 6XX/7XX series navigators (See section 1.6.1.11)
- GNS 4XX(W)/5XX(W) series navigators (See section 1.6.1.11)
- GNS 480 series navigator (See section 1.6.1.11)
- GTX 3x5 w/GPS transponder with software version 2.10 or later. (See section 1.6.1.11)



Additionally, the G5 functions provided by the GPS are shown below:

- Ground Track
- Ground Speed (GS)

1.6.1.5 Air Data

The G5 unit is connected to the aircraft Pitot / Static system. See section 4.1.2.4 for details.

The G5 functions provided by the air data are shown below:

- Secondary Airspeed indicator
- Secondary Barometric altimeter
- Secondary Vertical speed
- Secondary Altimeter Barometric Setting
- Secondary Altimeter
- Secondary Altitude Display
- Selected altitude setting, bug and visual altitude alerting
- Secondary Vertical Speed Indicator
- Vspeed references

1.6.1.6 Standby Battery

The standby battery is required. The G5 has an externally mounted lithium – ion battery that sustains the G5 flight display with up to 4 hours of emergency power.



Figure 1-2 G5 Standby Battery

1.6.1.7 G5 Attitude Interfaced to GMU 11

The GMU 11 magnetometer can be installed as an optional interface for a standalone G5 attitude display. This will allow the display of heading on the attitude display in place of track, but would not allow the removal of the existing DG.



1.6.1.8 G5 Attitude Interface Summary

The G5 Electronic Flight Instrument when configured as an attitude indicator in this STC installation uses 14VDC or 28 VDC power, ground, RS-232, CAN BUS and coax⁽¹⁾ connection for external mounted GPS antennas. The following list is a summary of interfaces used by the G5 Attitude indicator.

- Aircraft Power and Ground
- Aircraft Pitot/Static
- GPS Coax connection ⁽¹⁾
- One RS-232 connection
- One CAN Bus connection
- Standby battery

(1) Used only in installations utilizing an external GPS antenna for GPS input to the G5.

1.6.1.9 G5 Attitude Power and Ground Interface Summary

The G5 uses 14VDC or 28 VDC power and aircraft ground. Reference Section 5 for wiring details.

1.6.1.10 G5 Attitude Pitot/Static Interface Summary

The G5 requires pitot and static inputs for the altitude and airspeed functions. Reference Section 4.1.4 for installation specifics.

1.6.1.11 G5 Attitude RS-232 Interface Summary

The G5 Attitude indicator can utilize RS-232 connections when available to receive GPS data.

When a G5 HSI is installed, the G5 Attitude indicator can utilize the RS-232 connection for GPS and VHF navigation information.

If an existing connection is made to the RS-232 port, the G5 connection can be spliced into the existing wiring at the connector. For specific wiring information refer to Section 5.

For specific configuration settings for RS-232 refer to Section 5.



1.6.1.12 G5 Attitude CAN BUS Interface Summary

The G5 Attitude indicator can utilize CAN BUS connections when specified by a specific equipment configuration to allow heading information from the GMU 11, communication of navigation data from the GAD 29/29B and communication between the G5 Attitude indicator and the G5 HSI.

For specific wiring information refer to Section 5.

1.6.2 G5 DG/HSI Indicator

The G5 Electronic Flight Instrument configured as an HSI, is shown in Figure 1-3. The G5 is an electronic instrument display operating as a standalone flight display. It features a bright, sunlight readable, 3.5-inch color display which is sized to fit in a standard 3-1/8-inch instrument cutout. The G5 contains integrated attitude/air data sensors that provide a backup display of attitude and air data information. The G5 has battery backup and in the case of aircraft power loss will sustain G5 operation with up to 4 hours of emergency power. When the G5 is installed as a DG/HSI the battery backup is optional.



Figure 1-3 G5 Electronic Flight Instrument (DG/HSI)

The Garmin G5 indicator can replace an existing vacuum-driven or electro mechanical DG/HSI. In this location the G5's primary function is the display of slaved compass, #1 VHF NAV and/or #1 GPS NAV. The possible configurations for a G5 DG/HSI are discussed below. (Note: The VHF navigators and GPS navigators interfaced by this STC are not installed by this AML STC. Only the interface of the VHF NAV, GPS NAV and G5 Attitude and G5 DG/HSI are approved with this STC.)

1.6.2.1 G5 Slaved DG

The basic installation is a G5 in the DG indicator location and a GMU 11.

- In this configuration the G5 is installed as a slaved compass with no NAV information.
- The G5 DG can be used as a backup Attitude/Airspeed/Altitude Indicator.



1.6.2.2 G5 HSI VHF NAV

For installations where the G5 HSI is being used for basic VHF NAV, the G5 HSI is installed with a GNC255 or SL30.

- The G5 HSI will be a situationally correct display of VHF NAV course information with the heading of the aircraft
- The G5 HSI will be used to input OBS/Course information
- The G5 HSI can be used as a backup Attitude/Airspeed/Altitude Indicator
- If installed, a G5 Attitude indicator can also present VHF NAV lateral and vertical deviation

1.6.2.3 G5 HSI GPS NAV

For installations where the G5 HSI is being used for GPS NAV, the G5 will be installed with a Garmin GPS navigator and the GAD 29/29B

- The G5 HSI will be a situationally correct display of GPS NAV information with the heading of the aircraft
- The G5 HSI will be used to input OBS/Course information
- The G5 HSI can be used as a backup Attitude/Airspeed/Altitude Indicator
- If installed, a G5 Attitude indicator can also present GPS NAV lateral and vertical deviation

1.6.2.4 G5 HSI VHF NAV and GPS NAV

For installations where the G5 HSI is being used for full VHF NAV and GPS NAV, the G5 will be installed with a Garmin GPS/VHF navigator and the GAD 29/29B.

- The G5 HSI will be a situationally correct display of VHF NAV or GPS NAV information with the heading of the aircraft
- The G5 HSI will be used to input OBS/Course information
- The G5 HSI can be used as a backup Attitude/Airspeed/Altitude Indicator
- If installed, a G5 Attitude indicator can also present VHF NAV or GPS NAV lateral and vertical deviation

1.6.2.5 Backup Attitude Indicator

All of the functions listed in 1.6.1 are also available by selecting the G5 HSI Menu via the knob and selecting PFD.

1.6.2.6 G5 DG/HSI Interface Summary

- Aircraft Power and Ground
- Aircraft Pitot/Static
- GPS Coax connection ⁽¹⁾
- One RS-232 connection
- One CAN Bus connection
- Standby battery (optional)

⁽¹⁾ Used only in installations utilizing an external GPS antenna for GPS input to the G5.



1.6.2.7 G5 DG/HSI Power and Ground Interface Summary

The G5 uses 14VDC or 28 VDC power and aircraft ground. Reference Section 5 for wiring details.

1.6.2.8 G5 DG/HSI Pitot/Static Interface Summary

The G5 requires pitot and static inputs for the backup altitude and airspeed functions. Reference Section 4.1.4.

1.6.2.9 G5 DG/HSI RS-232 Interface Summary

The G5 DG/HSI can utilize RS-232 connections when available to receive

- GPS data for aiding.
- VHF navigation information, both lateral and vertical.

For specific configuration settings for RS-232 refer to Section 5.

If an existing connection is made to the RS-232 port, the G5 connection can be spliced into the existing wiring at the connector. For specific wiring information refer to Section 5.

1.6.2.10 G5 DG/HSI CAN BUS Interface Summary

The G5 DG/HSI can utilize CAN BUS connections when specified by a specific equipment configuration to allow heading information from the GMU 11, communication of navigation data from the GAD 29/29B and communication between the G5 Attitude instrument and the G5 HSI.

For specific wiring information refer to Section 5.

1.6.2.11 Standby Battery

The standby battery is optional for the DG/HSI installation. The G5 has an externally mounted lithium – ion battery that sustains the G5 flight display with up to 4 hours of emergency power.

1.6.3 GMU 11 Magnetometer

The Garmin GMU 11 Magnetometer is a remote mounted device that interfaces with a Garmin G5 to provide heading data to the G5 Attitude and/or G5 DG/HSI. The Garmin G5 and GMU 11 magnetometer replaces traditional rotating mass instruments. The GMU 11 Magnetometer uses magnetic field measurements to create electronically stabilized heading data. The GMU 11 is required when a G5 is installed as a DG/HSI.



Figure 1-4 GMU 11

1.6.4 GAD 29/29B

The GAD 29/29B is a light-weight, remote-mount unit that allows interface to IFR navigators such as the GNS and GTN series. The GAD 29/29B has a 25 pin D-sub connector and a 9 pin D-sub connector. These connectors provide the following functionality:

- 2 Low Speed ARINC 429 Transmitters
- 4 Low Speed ARINC 429 Receivers
- 1 CAN Network Port
- *Analog Outputs
- *Excitation Pass Through

*GAD29B only

For the G5 Attitude and/or G5 DG/HSI installation the GAD 29/29B will receive either ARINC 429 data from the navigator interfaced and transmit that information onto the CAN bus to be consumed by the G5. The GAD 29/29B can run on 14 volt DC or 28 volt DC.

The GAD 29B contains the same characteristics and function of the GAD 29 as well as providing autopilot heading and course datum to allow a G5 DG/HSI to be interfaced with third party auto pilots. Reference section 5.12 for approved autopilot interfaces.



Figure 1-5 GAD 29/29B

1.7 Technical Specifications

1.7.1 Physical Characteristics

All width, height, and depth measurements are taken with unit rack, if applicable, and connectors.

Table 1-3: Physical Characteristics

Configuration	Width	Height	Depth	Unit Weight	Weight of Unit and Connector
G5 with Battery	3.42 in	3.60 in	3.03 in*	0.83 lb	0.98 lb**
GAD 29	6.10 in	1.48 in	5.54 in	0.38 lb	0.63 lb
GAD 29B	6.10 in	1.48 in	5.54 in	0.40 lb	0.65 lb
GMU 11	2.74 in	0.92 in	6.19 in	0.16 lb	0.26 lb
*Depth behind aircraft panel			**Weight includes mounting ring		



1.7.2 Power Requirements

Table 1-4: Power Requirements

LRU	Characteristics	Specifications
G5	Average Current Draw @ 14 VDC	.200 A
	Max Current Draw @ 14 VDC	.250 A
	Average Current Draw @ 28 VDC	.100 A
	Max Current Draw @ 28 VDC	.125 A
GMU 11	Average Current Draw @ 14 or 28 VDC	.100 A
	Max Current Draw @ 14 or 28 VDC	.100 A
GAD29/29B	Average/Max Current Draw @ 14 VDC	.200 A
	Average/Max Current Draw @ 28 VDC	.100 A

2 LIMITATIONS

2.1 Installation Limitations

It is the installer's responsibility to ensure the installation will meet the requirements in this manual prior to modification of the aircraft.

The installation of the G5 requires the retention of the mechanical airspeed indicator, altimeter, and vertical speed indicator.

- For installations in aircraft approved for IFR operations:
 - If the G5 is installed as the primary attitude indicator, the existing rate of turn indicator must be retained.
 - If the G5 is installed as the rate of turn indicator, the existing primary attitude indicator must be retained.
- For installations in aircraft approved for VFR-only operations;
 - The G5 can be installed as the attitude indicator and rate of turn indicator without retention of either the existing attitude indicator or rate of turn indicator.

As installed by this STC, the G5:

- is NOT approved in FAA certified aircraft that:
 - are approved for Flight Into Known Icing (FIKI) conditions
 - have a gross take-off weight more than 6000 lbs
 - have more than 6 seats including pilot/copilot
- must be installed in an aircraft with an electrical power generating system capable of supplying 14 VDC or 28 VDC
- if a G5 is being installed as an attitude indicator and an existing attitude indicator is retained, the G5 pointer type must be configured to match the existing indicator pointer type
 - Fixed Pointer Type / G5 Config = Ground
 - Movable Pointer Type / G5 Config = Sky
- cannot replace a primary attitude indicator that includes a flight director or is part of an autopilot system (an existing attitude indicator in the primary location that is part of an autopilot but without flight director may be moved to the turn coordinator location and a G5 installed in the primary location)
- cannot replace the turn coordinator that is part of an autopilot system



- cannot replace a DG/HSI that is part of an autopilot system that is not an approved autopilot, see Table 5-1.
- cannot replace the non-stabilized magnetic compass (Whiskey Compass must be retained in the aircraft)
- must be installed in an instrument panel constructed of aluminum with a minimum thickness of .040 inches.
- is only approved to interface with aircraft systems specified in this manual
- must not have interface cables and wiring installed in fuel bays

2.2 Operational Limitations

Refer to the Airplane Flight Manual Supplement (AFMS) for operational limitations.

This area intentionally blank



3 INSTALLATION OVERVIEW

3.1 Introduction

The following section contains an overview of the steps required for the installation of the G5 Electronic Flight Instrument. This section includes requirements for selection of proper locations in the aircraft, as well as requirements for supporting structure, mechanical alignment and wiring. Any restrictions on nearby equipment and requirements are also specified.

3.2 Installation Materials

The installation kit listed in Table 3-1 is required for each G5 installation.

Table 3-1: Contents of the G5 Installation Kit (011-03892-00)

Item	Garmin P/N	Quantity
Connector Kit, 9 Pin, w/CAN Term*	011-03002-00	1
Mounting Ring, G5	115-02251-03	1
Screw, 6-32, 0.500"	211-60207-12	3

*NOTE: Not all items included in kit P/N 011-03002-00 are used in this installation.

The installation kit listed in Table 3-2 is required any time a GMU 11 is installed.

Table 3-2: Contents of the GMU 11 Installation Kit (011-04349-90)

Item	Garmin P/N	Quantity
Connector Kit, 9 Pin, w/CAN Term	011-03002-00	1
Nylon Locking 6-32 Nut	210-10008-08	4
Screw, 6-32, 0.500"	211-60207-12	4
Flat 6-32 Washer	212-00024-06	4

Table 3-3: Contents of the Connector Kit (011-03002-00)

Item	Garmin P/N	Quantity
Sub-Assy, Bkshl w/Hdw, Jackscrew, 9 pin	011-01855-00	1
Sub Assy, CAN Termination Kit*	011-02887-00	1



Conn, Rcpt, D-Sub, Crimp Socket, 9 Ckt	330-00625-09	1
Contact, Sckt, D-Sub, Crimp, Size 20, 20-24 AWG	330-00022-02	9

*NOTE: Not all items included in kit P/N 011-02887-00 are used in this installation

The installation kit listed in Table 3-4 is required whenever a GAD 29/29B is installed.

Table 3-4: Contents of the GAD 29/29B Connector Kit (011-03271-00)

Item	Garmin P/N	Quantity
Backshell w/Hdw, Jackscrew, 9 Pin	011-01855-00	1
Backshell w/Hdw, Jackscrew, 25 Pin	011-01855-02	1
Conn, Plug, D-Sub, Crimp Pin, 25 Place	330-00624-25	1
Conn, Rcpt, D-Sub, Crimp Sckt, 9 Place	330-00625-09	1
Contact, Socket, Military Crimp, Size 20	336-00022-02	11
Contact, Pin, Military Crimp, Size 20	336-00024-00	27

The item listed in Table 3-5 will be supplied when a G5 DG/HSI is ordered. The adapter plate is used whenever a G5 is installed and any instrument panel modification has taken place or a G5 is installed in an instrument hole with cutouts for instrument knobs. Alternatively the installer can field fabricate the adapter as needed. Reference 4.1.2.4 for installation details.

Table 3-5: G5 Adapter Plate

Item	Garmin P/N	Quantity
G5 Adapter Plate	115-02642-00	As required

The item listed in Table 3-6 is optional. It can be ordered from Garmin or fabricated in accordance with Section 4.1.2.6. The recessed adapter plate is only used when recessing the G5 into the instrument panel. This same part can be used when installing single or dual recessed G5 units. Reference 4.1.2.6 for installation details.

Table 3-6: G5 Recessed Adapter Plate

Item	Garmin P/N	Quantity
G5 Recessed Adapter Plate	115-02733-00	As required



3.2.1 Materials Required but Not Supplied

The following installation materials are required, but are not available from Garmin:

- Insulated stranded wire (MIL-W-22759/34 or MIL-W-22759/16)
- Shielded wire (MIL-C-27500 cable utilizing M22759/34 wire (SD) and ETFE jacket or MIL-C-27500 cable utilizing M22759/16 wire (TE) and ETFE jacket)
- Push/pull manually resettable circuit breakers.
Aircraft with 14 VDC or 28 VDC electrical systems require the following circuit breaker:
 - MS26574-5 (5 Amp, G5, GMU 11, GAD 29/29B)
- Tie wraps or lacing cord
- MS25036 ring terminals (for grounding and circuit breaker connections)
- Shield terminators (AS83519/1-X or equivalent)
- Silicon fusion tape, A-A-59163 (MIL-I-46852C or equivalent)
- Environmental splice (M81824/1-X, where X=size or equivalent)
- Flat braid, 1/16" (AA59569F36T0062 or equivalent)
- Tubing and fittings are required to connect pitot and static air to the G5. Pitot and Static plumbing parts are aircraft specific, see Section 4.1.4.

The following installation materials may be required depending on the installation, but are not available from Garmin:

- 2024-T3 aluminum alloy sheet per AMS-QQ-A-250/4 or clad 2024-T3 aluminum alloy sheet per AMS-QQ-A-250/5. Minimum sheet thickness requirements:
 - 0.032" for GMU 11 magnetometer supporting structure.
 - 0.040" for GAD 29/29B supporting structures.
- Aircraft grade fasteners e.g., AN525 screws, MS20426AD rivets, MS21059 rivet nut plates, MS21071 reduced rivet spacing nut plates. NAS1832, NAS1834, or NAS1836 potted inserts maybe required if honeycomb core panels are used to support the installation of G5 components.
- Coaxial cable (RG-400, RG142B or equivalent) (refer to Section 3.4.5.3).
- Connector, TNC, male, crimp (M39012/26-0503, 225555-6, 31-4452 or equivalent).
- Connector, BNC, male, crimp (M39012/16-0503, 225395-6 or equivalent).



3.3 Test Equipment

The following test equipment is required to complete the G5 installation and to perform post-installation checkout of the system:

- Ground power cart (capable of supplying power to the aircraft systems and avionics)
- Air data test set (e.g. Barfield DPS450 or similar)
- VHF NAV test set
- Low resistance ohmmeter
- Digital Level (or equivalent)

The following equipment may be required based on the units being installed and the particular aircraft, see Section 4.1 for information:

- Laser Square
- Protractor Tool
- Plumb Bob
- Aircraft Jack Set

3.4 Installation Considerations

The installation instructions are intended to be used in coordination with the avionics installation practices in AC 43.13-1B and AC 43.13-2B.

- Modification of existing plastic instrument panel overlays may be required to install the G5 electronic flight instrument.
- Fabrication of a wiring harness is required.
- Sound mechanical and electrical methods and practices are required to achieve optimum system performance.

3.4.1 GPS Antenna

A GPS signal is required. The G5 can use an external GPS antenna or GPS data from one of the GPS navigators or GTX 3x5 listed in Section 5.

In a dual G5 installation only the G5 Attitude requires the GPS position input. The GPS information is communicated to the G5 DG/HSI over the CAN Bus.

If a GPS Navigator or a GTX 3x5 is used for a GPS signal, disable the internal GPS receiver of the G5. If an external GPS antenna is connected to the G5, enable the internal GPS receiver. See Section 5 for configuration settings.

This STC approves the interface to antennas shown in Table 3-7 and Table 3-8.

This STC does not approve the installation of a GPS antenna. A separate airworthiness approval for antenna installation is required except for existing or previously approved installations. One means of installation approval is Garmin Antenna STC SA02018SE-D for mounting GPS antennas.

Other antennas that meet the specifications listed in Table 3-9 will work with the G5, but it is the installer's responsibility to ensure that their choice of antenna meets FAA standards according to this specific installation.



3.4.1.1 GARMIN ANTENNAS

Table 3-7 lists Garmin antennas supported by the G5. The GA35 and GA36 meet the requirements of TSO/ETSO-C144.

Table 3-7 Supported Garmin Antennas

Model	Connector Type	Part Number
GA35	TNC	013-00235-0X
GA36	TNC	013-00244-0X
GA56	TNC	011-00134-00

3.4.1.2 NON-GARMIN ANTENNAS

Table 3-8 lists non-Garmin antennas supported by the G5. For non-Garmin antennas, follow the manufacturer's installation instructions.

Table 3-8 Supported Non-Garmin Antennas

Model	Antenna Type	Mfr	Part Number
Comant 2480-201 VHF/GPS*	VHF COM/ GPS	Comant	CI 2480-201

*The GPS antenna connector is TNC type. The VHF COM antenna connector is BNC type.

An antenna meeting the specifications in Table 3-9 is capable of receiving both GPS and WAAS signals when connected to the G5.

Table 3-9 GPS Antenna Minimum Requirements

Characteristics	Specifications
Frequency Range	1565 to 1585 MHz
Gain	16 to 25 dB typical, 40 dB max
Noise Figure	Less than 4.00 dB
Nominal Output Impedance	50 Ω
Supply Voltage	4.5 to 6.5 VDC
Supply Current	up to 60 mA

3.4.2 Considerations for Vacuum System

If a vacuum driven instrument is removed, the vacuum source must be capped and the system checked for leaks. See the aircraft specific maintenance manual for procedure.

The vacuum system and associated parts may be removed if there is no remaining need for vacuum. See the aircraft specific maintenance manual and AC 43.13-2B for guidance when removing the vacuum system. If the vacuum pump is removed, the engine accessory port must be properly covered. See specific engine maintenance and parts manuals for guidance.



3.4.3 Switches

There are no switches added by this STC installation.

3.4.4 Placards and Labels

All placards and labels should be readable in all lighting conditions. Ambient flood lighting is acceptable. The new circuit breaker installed for the G5 unit and supporting equipment must be labeled as noted in the interconnect drawings in Section 5. These labels are summarized in Table 3-10.

Table 3-10: G5 and Supporting LRU Circuit Breaker Labels

Description	Label	
	Single G5 Installation	Dual G5 Installation
G5 (Attitude Indicator)	ATT [1]	ATT [1]
G5 (DG/HSI)	HSI or DG	HSI or DG
GMU 11	[2]	[2]
GAD 29/29B	GAD	GAD

[1] Circuit breaker is labeled “ATT” when the G5 is installed in the primary attitude position. When an existing primary attitude indicator is retained the G5 installed in the Turn Coordinator position should be labelled #2 ATT. Alternate spellings of “ATT” is acceptable.

[2] When a single G5 is installed, the GMU 11 is powered from the same breaker as the G5. When two G5s are installed, the GMU 11 is powered from the same breaker as the G5 in the DG/HSI position.

3.4.5 Cable and Wiring Considerations

Select wire in accordance with AC 43.13-1B Chapter 11, Sections 5 through 7. Mark wire in accordance with AC 43.13-1B Chapter 11 Section 16. Mark harness connectors in accordance with AC 43.13 Chapter 11 Section 17. Install wiring in accordance with AC 43.13-1B Chapter 11, Sections 8 through 13. Record the aircraft wire routing in Appendix C of *Garmin G5 Electronic Flight Instrument Part 23 AML STC Maintenance Manual including Instructions for Continued Airworthiness*, P/N 190-01112-11. Use the following guidelines to prevent damage to the aircraft and systems:

- Do not route the wire harness near flight control cables, high electrical capacity lines, high-energy sources or fuel lines.
- Locate the wire harness in a protected area of the aircraft.
- Make sure the wire harness does not come in contact with sources of high heat or be routed adjacent to RF coaxial cables.
- Make sure there is ample space for the wire harness and mating connectors.
- Avoid sharp bends.

3.4.5.1 Pressurized Aircraft Considerations

In pressurized aircraft, wiring that penetrates the pressure vessel must be installed in accordance with the Type Design of the aircraft. Any wires that penetrate the pressure bulkhead must use existing provisions such as spare pins in the existing bulkhead connectors, or existing sealed wire thoroughfares in accordance with the AMM. Substantiation for additional holes in the pressure vessel is beyond the scope of this manual and would require additional data from the aircraft manufacturer or other FAA approved data.

3.4.5.2 CAN Bus

The primary digital interface used to exchange data between the G5 Attitude indicator, GMU 11 and GAD 29/29B is the Controller Area Network, also known as the CAN bus. CAN was developed by Bosch GmbH in the 1980s, and its specifications are currently governed by ISO 11898-2. CAN is widely used in aviation, automotive, and industrial applications due to its simplicity and reliability.

CAN BUS ARCHITECTURE

The electrical architecture of the CAN bus takes the form of a linear “backbone” consisting of a single twisted wire pair with an LRU connected (terminated) at each end (Figure 3-1). The installer should attempt to make this “backbone” as short as practical. The maximum overall length of the CAN bus from end to end should be 85 feet. At each of the two extreme ends of the CAN bus, a 120 Ω resistor is installed to “terminate” the bus. Termination resistors are either provided via termination adapters that plug into an LRU’s CAN connection or are internal to the LRU.

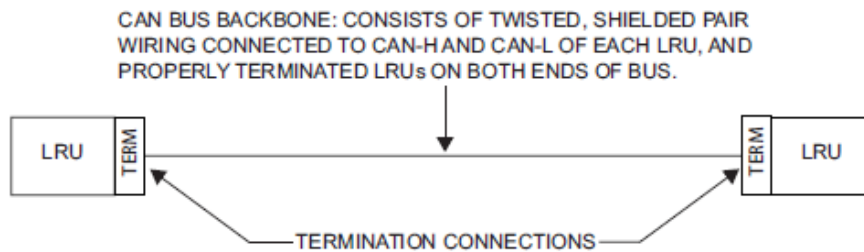

Figure 3-1 CAN Bus Backbone

Multiple LRU’s may be connected in a daisy chain manner along the backbone of the CAN bus (Figure 3-2).

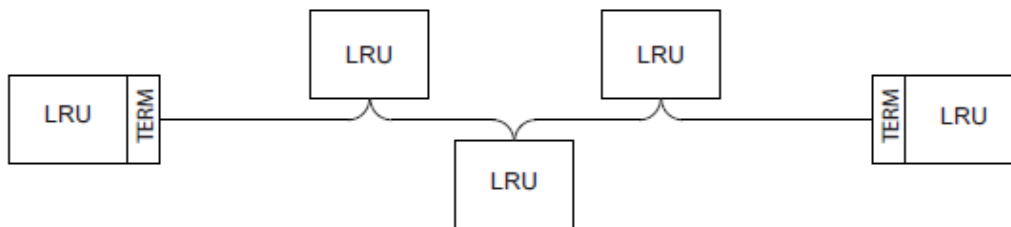

Figure 3-2 Correct CAN BUS Wiring Example and Node Connections

Daisy-chained LRUs (LRUs not at the extreme ends of the CAN bus) connect to the CAN backbone through short “stub” or “node” connections (Figure 3-2). The length of each node connection should be 3 inches or less, the maximum allowed distance from a splice to a connector.

Multiple devices must not connect to the CAN bus backbone at the same point. Rather than splicing two or more stub node connections together, the CAN bus should instead be daisy-chained from one device to the next (Figure 3-2).

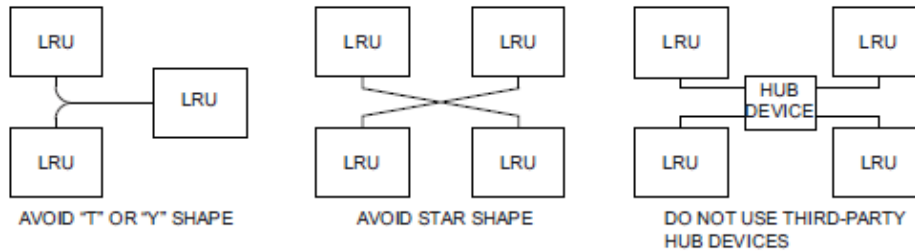

Figure 3-3 Incorrect CAN Wiring Example

CAN BUS WIRING

Wiring used for the CAN bus should be shielded twisted-pair cable, MIL-C-27500. The shields for each CAN bus wire segment should be interconnected, forming a continuously connected shield from one end of the CAN bus to the other end of the CAN bus. The CAN bus shield should always be grounded to the device connector backshells for all devices connected the CAN bus.

CAN BUS TERMINATION

At each of the two extreme ends of the CAN bus backbone, a 120 Ω resistor is installed to terminate the bus. In the G5 system, separate resistors are not required. Instead, termination resistors are provided either via termination adapters that plug into an LRU’s CAN connection or via an internal resistor.

- The G5 and GMU 11 installation kits provide a 9-pin termination adapter that provides termination when attached to the device’s main connector. The termination adapter contains a 120 Ω resistor that is connected between pins 1 and 2 (Figure 3-4).
- The GAD29/29B contains a 120 Ω resistor inside the unit that provides termination when the two CAN TERM pins are connected together (Figure 3-5). Alternatively the GAD29/29B can be terminated externally using a termination adapter, Garmin P/N 011-02887-00 (Figure 3-4).

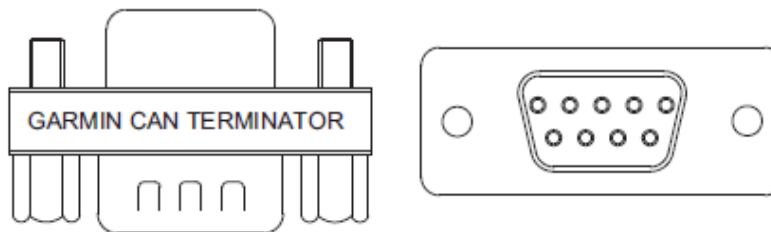

Figure 3-4 CAN Bus Termination (011-02887-00) for G5 and GMU 11

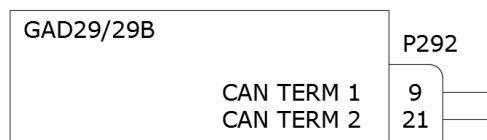

Figure 3-5 CAN Bus Termination for GAD 29/29B



Both ends of the CAN bus must have a CAN bus terminator installed (Figure 3-2), but devices that are not at the ends of the CAN bus should not have a CAN bus terminator installed .

CAN BUS INSTALLATION GUIDELINES

For maximum reliability of the CAN bus, the following guidelines should be followed:

- The CAN bus backbone must be a single linear path with exactly two distinct ends. CAN bus connections should be “daisy chained” from device to device. Avoid “star” and “Y” topologies, and do not use a hub device (see Figure 3-3).
- The overall length of the bus should not exceed 85 feet.
- Do not connect more than one device to the CAN bus backbone at the same point. Instead, daisy chain the CAN bus backbone from one device to the next.
- Observe proper wiring, shielding, and grounding requirements as described above.
- Terminate the CAN bus at the two extreme ends of the bus, as described above.
- When adding a new device to the CAN bus, evaluate proposed modifications to the CAN bus wiring connections to ensure compliance with all above requirements.

3.4.5.3 Coaxial Cable Considerations

When routing coaxial cables, observe the following precautions:

- All cable routing should be kept as short and as direct as possible.
- Avoid sharp bends.
- Avoid routing cables near power sources (e.g. 400 Hz generators, trim motors, etc.) nor near power for fluorescent lighting.

Refer to Section 3.2.1 for recommended coaxial cable types.

3.4.6 Cooling Requirements

While no forced cooling air is required for the G5, GMU 11 or GAD 29/29B it is highly recommended that the air behind the panel be kept moving (by ventilation or a fan). Units tightly packed in the avionics stack heat each other through radiation, convection, and sometimes by direct conduction. Even a single unit operates at a much higher temperature in still air than in moving air. Fans or some other means of moving the air around electronic equipment are usually a worthwhile investment.



NOTE

Avoid installing LRUs near heat sources. If this is not possible, ensure that additional cooling is provided. Allow adequate space for installation of cables and connectors. The installer will supply and fabricate all of the cables. Install wiring in accordance with FAA AC 43.13-1B and AC 43.13-2B.

3.4.7 Compass Safe Distance

After reconfiguring the avionics in the cockpit panel, if the unit is mounted less than 12 inches from the compass, recalibrate the compass and make the necessary changes for noting correction data.



3.4.8 Shield Termination Considerations

For G5 installations utilizing the RS-232, CAN bus and ARINC 429 interfaces, terminate the shield to the G5, GMU 11 and GAD 29/29B connector backshells as shown in Figure 4-42 and Figure 4-43. For shield terminations at the GPS or VHF Navigator follow the appropriate installation techniques as indicated by the manufacturers installation instructions for that unit. If there are any interposing connectors then the shields must have continuity through the interposing connector. This can be achieved by

- 1) Terminating the shields to the backshell of the connector if both mating connectors and both backshells are metal.
- 2) Terminating the shield to aircraft ground directly
- 3) Passing the shield through pins in the connector. This is the least preferred method.

3.4.9 Audio Interference

This STC installation does not interface to audio signals. Attention to harness installation and routing as specified in Section 3.4.5 should be considered for Audio interference mitigation.

This area intentionally blank



4 INSTALLATION PROCEDURES

4.1 Mechanical Installation

4.1.1 Special Tools Required

Laser Square

For GMU 11 magnetometer installations it is recommended (but optional) to use a laser square with a line accuracy of $\pm 3/32$ inches end-to-end, at 15 feet perpendicular distance (or better). A Stanley Laser Level Square 77-188 S2 meets the line accuracy requirement.

Digital Level

It is recommended to use a digital level when installing GMU 11 magnetometer.

Protractor Tool

A protractor tool may be required to measure the angle offset during the magnetometer installation.

Plumb Bob

A plumb bob may be required for leveling and installing the magnetometer unit.

Aircraft Jack Set

A set of aircraft jacks may be required for stabilizing the aircraft after it is leveled.

4.1.2 G5 Mounting Requirements



NOTE

It is important that the G5 is installed perpendicular to the aircraft's longitudinal axis (display bezel parallel to the wing spar carry thru) and as close to level in the roll axis as possible. Small roll offsets and pitch offsets, up to 15°, can be corrected for during calibration.

In addition to the installation limitations in Section 2.1, consider the following when selecting a mounting location for the G5:

- Protect the mounting location for the G5 from rapid thermal transients, in particular large heat loads from nearby high-power equipment.
- Do not install the G5 within 1 inch of magnetically mounted antennas, speaker magnets, or other strongly magnetic items.
- If installing dual G5s above and below each other, a minimum spacing of 3.6 inches center to center is required, see Section 4.1.2.4 for more information.
- Two Adapter Plates must be used if installing the G5 in an instrument hole with any cutout for instruments knobs. See Figure 4-10 and Figure 4-12 for more information.

One or two G5s may be installed. See Figure 4-1 for typical installation configurations in an IFR approved aircraft.

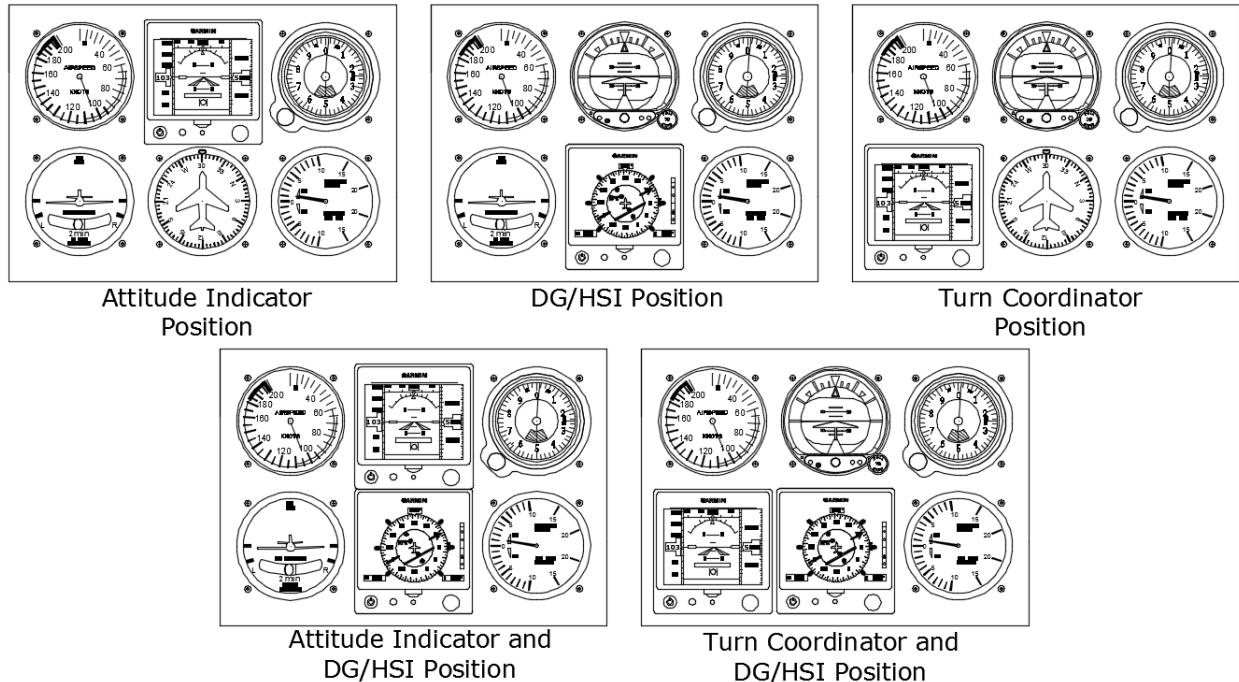

Figure 4-1 Typical G5 Installations for IFR Approved Aircraft

A G5 can be installed in an instrument panel that does not have an existing attitude indicator or DG/HSI. In these cases, the G5 must be located on the Pilot's instrument panel, and centered as nearly as practicable about the vertical plane of the pilot's forward vision. If the G5 is installed as an;

- Attitude indicator, it must be located as close to the top center position of the pilot's instrument panel as practical.
- DG/HSI, it shall be located adjacent to and directly below the instrument in the top center position when possible.

4.1.2.1 Mounting Ring Installation

The G5 Mounting Ring (115-02251-03) can be used as a template when marking the panel for cutout. For complete cutout dimensions see Figure 6-11.

Secure the mounting ring to the aircraft panel using the supplied #6-32 pan head Phillips mounting screws. Evenly torque the mounting screws to 10-12 in-lbs.

- The G5 must be leveled to within 15.0° in the longitudinal axis (Pitch). (Reference Figure 4-4)
- The G5 must be leveled to within 2.0° in the lateral axis (Roll). (Reference Figure 4-3)
- Mount the G5 with the connector aligned to within 1.0° of the vertical axis (Yaw) of the aircraft (display bezel parallel to the wing spar carry thru). (Reference Figure 4-5)

An aircraft leveling and offset calibration procedure must additionally be carried out prior to flight.

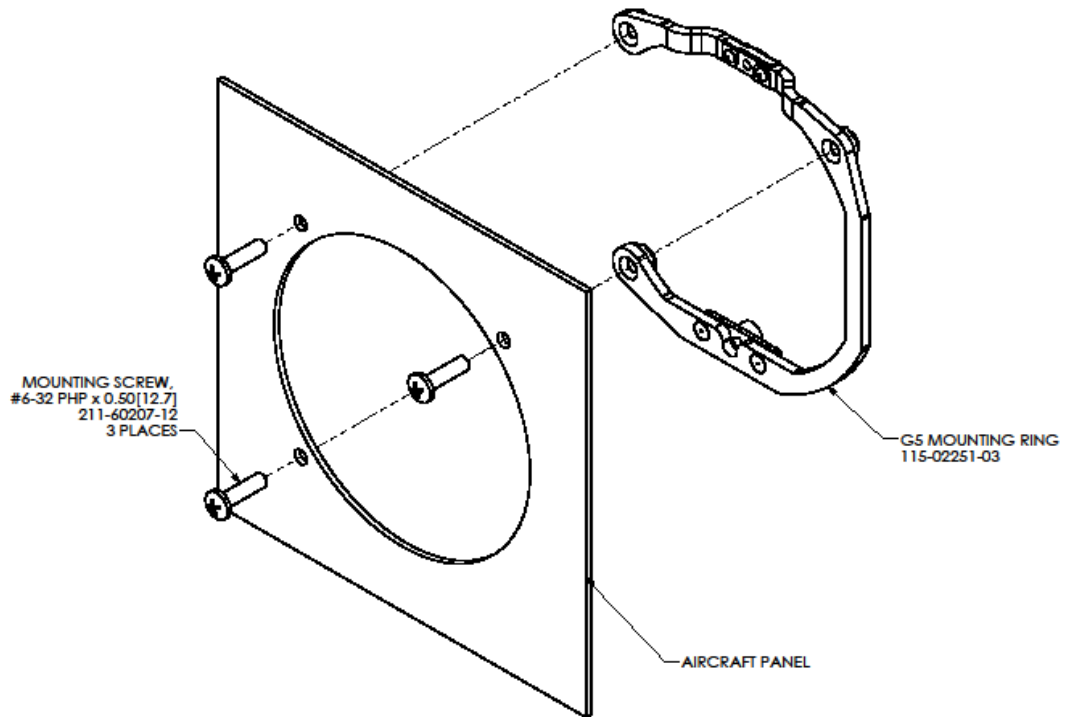

Figure 4-2 G5 Mounting Ring

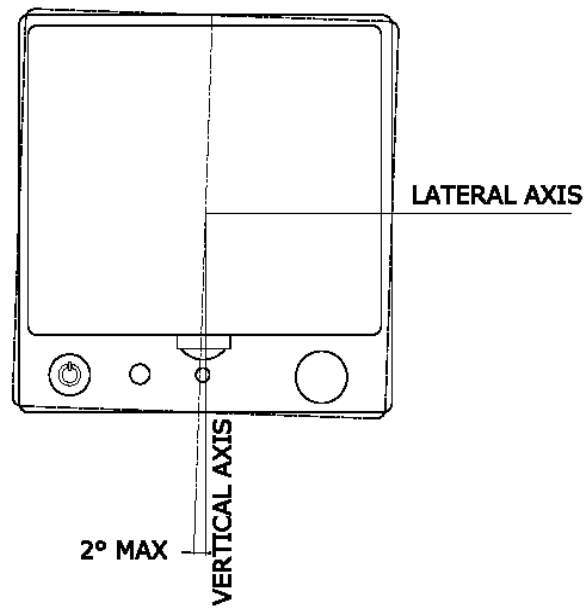

Figure 4-3 Maximum Misalignment of the G5 in the Lateral Axis

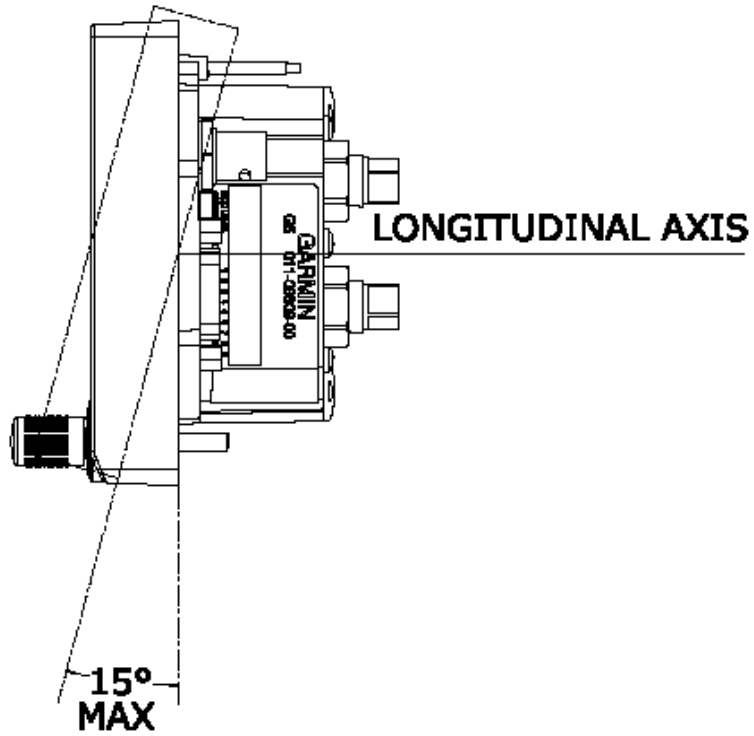

Figure 4-4 Maximum Misalignment of the G5 in the Longitudinal Axis

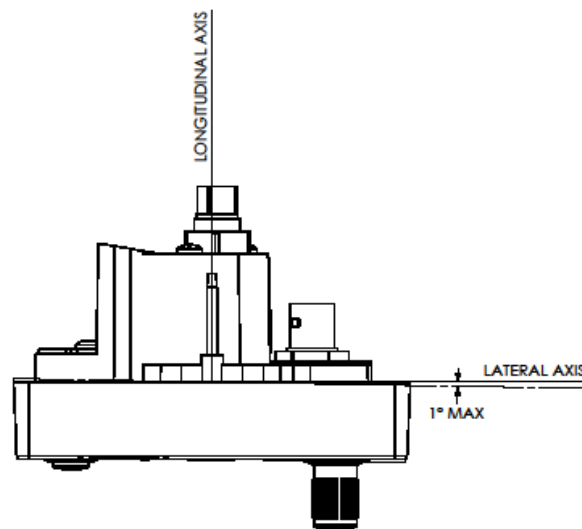

Figure 4-5 Maximum Misalignment of the G5 in the Vertical Axis

4.1.2.2 G5 Installation

The G5 is installed by inserting the alignment pin located at the top of the unit into the mating hole in the mounting ring, pushing the unit flush with the instrument panel, and fastening the captive 3/32" hex socket head screw to the mounting ring as shown in Figure 4-6. To fasten the captive screw to the mounting ring, insert a 3/32" hex drive tool through the access hole in the front cover of the G5 as shown in Figure 4-7. Torque the captive mounting screw to 10-12 in-lbs.

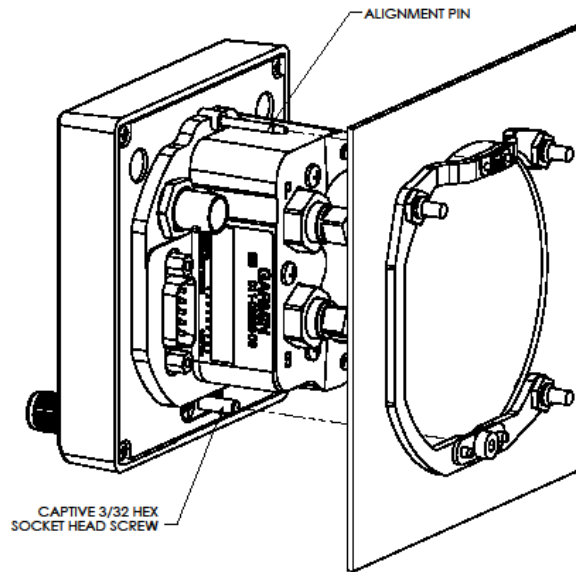

Figure 4-6 G5 Alignment Pin

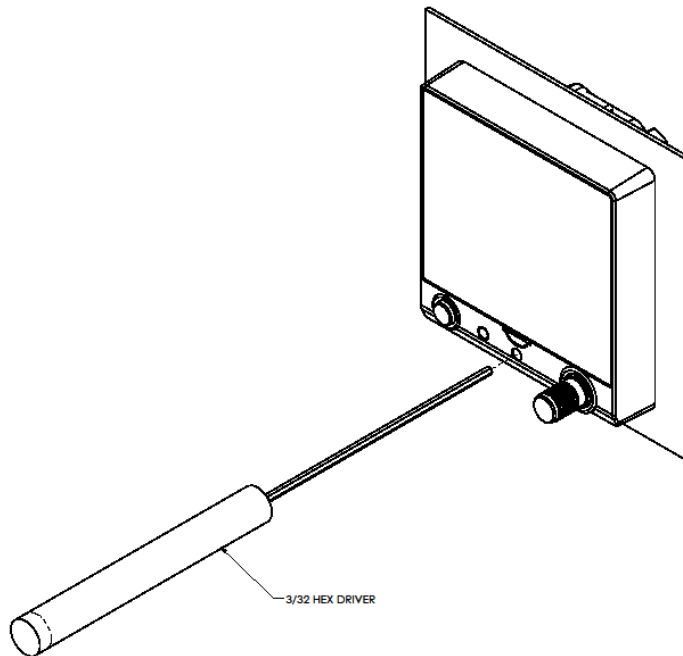

Figure 4-7 G5 Hex Driver Insertion

4.1.2.3 Optional #6-32 Captive Mounting Screw

The captive 3/32" hex socket head screw can be used for panel thicknesses up to 0.150". For installations with a panel thickness greater than 0.150", the captive mounting screw can be replaced with a standard #6-32 hex socket head screw (MS16995). To replace the screw, remove the two #4-40 flat head Phillips mount plate screws, the G5 screw mount plate, and the captive screw as shown in Figure 4-8. Reverse this process to install the longer #6-32 hex socket head screw. Ensure correct orientation of the screw mount plate before applying 6-8 in-lb. of torque to the #4-40 mount plate screws.

NOTE: Standard #6-32 hex socket head screws use a 7/64" hex drive feature. The access hole in the G5 bezel is large enough to accommodate this increase in hex tool size.

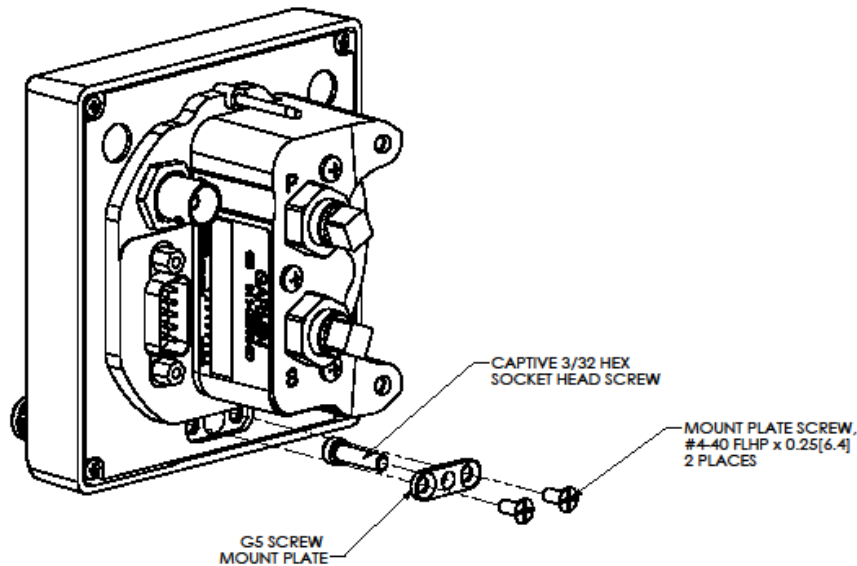

Figure 4-8 G5 Captive Mounting Screw Replacement

This area intentionally blank

4.1.2.4 Dual G5 Installations Requiring Instrument Panel Modification

The minimum vertical distance needed between two G5 units is 3.6 inches center to center. Some instrument panels may require modification of existing holes to gain the needed 3.6 inch spacing.

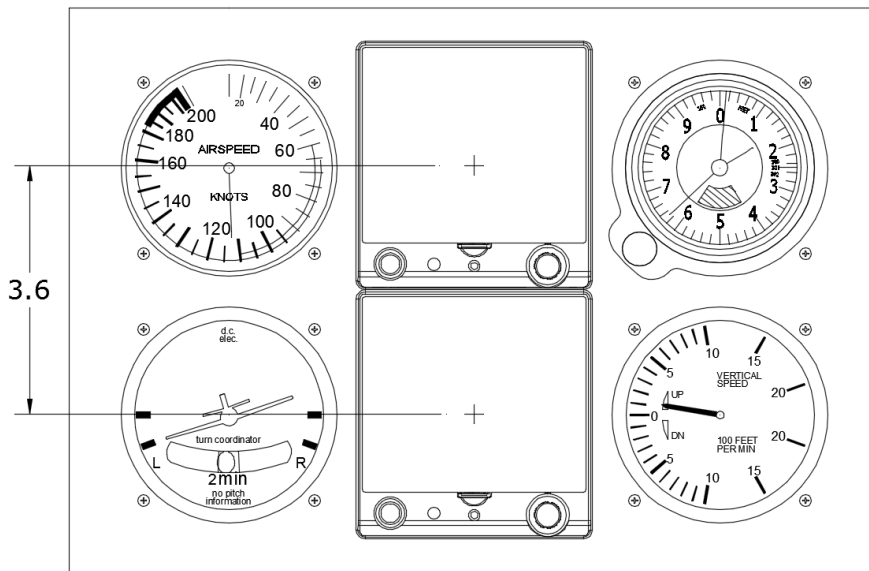

Figure 4-9 Required Vertical Spacing Between G5 Units

The panel may be modified by enlarging one hole or both, up to a maximum of 0.25 inch per instrument hole. The proposed positions must be such that neither G5 unit is obscured by the glareshield, control yoke or other object.

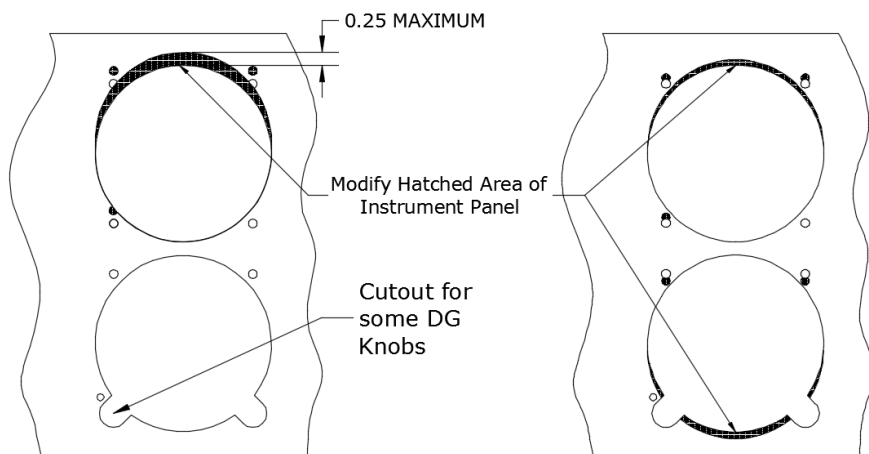

Figure 4-10 Instrument Panel Modification

The G5 Adapter Plate, (115-02642-00) is shown in Figure 4-11. Each installation of a G5 in a DG/HSI will include 2 adapter plates. Two G5 adapter plates must be installed as shown in Figure 4-12 when

- any instrument panel modification has taken place
- G5 is installed in an instrument hole with cutouts for instrument knobs

The G5 adapter plate is fabricated from 0.050 thick 2024-T3 aluminum per the dimensions shown in Figure 4-11. Apply a finish coat of paint to adaptor plates as desired prior to final installation. These may be field fabricated if needed and must have some type of corrosion protection (primer, alodine, etc.).

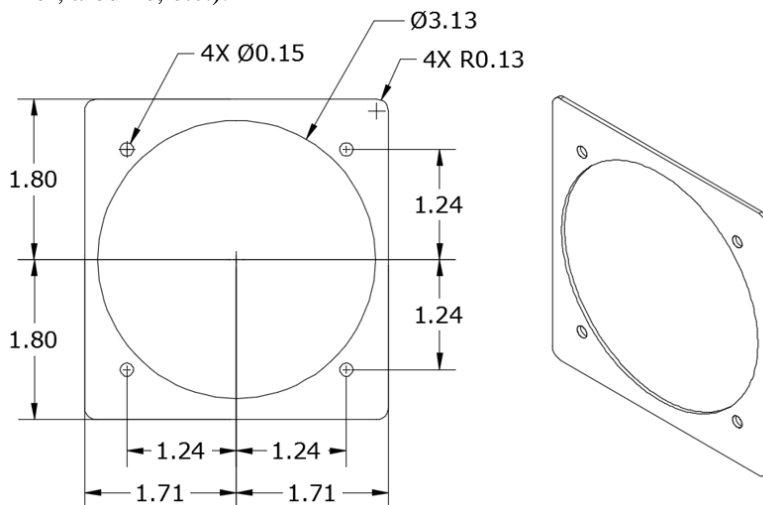

Figure 4-11 G5 Adapter Plate

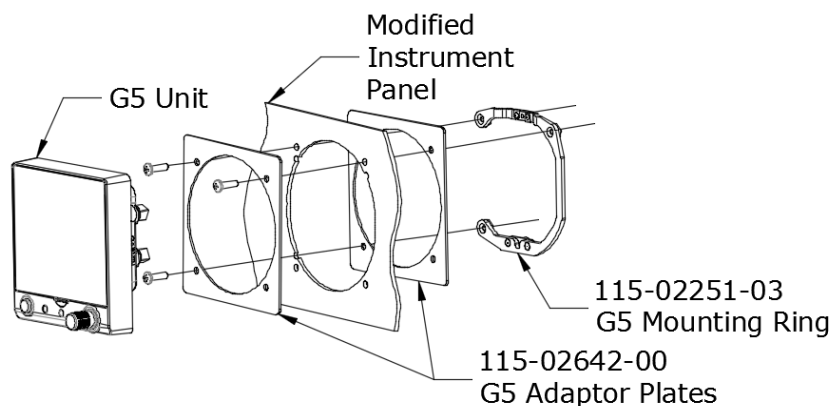

Figure 4-12 G5 Adapter Plate Assembly

4.1.2.5 Cutting a New Instrument Hole for G5 Installation

For G5 installations in aircraft approved for VFR-only operation, there may be the need to cut a new instrument hole.

If it is desired to mount the G5 recessed, refer to Section 4.1.2.6 for instructions and limitations.

In order to satisfy the structural requirements when cutting a new instrument hole in the existing panel, the following conditions must be met:

- 1) Modification of the instrument panel must be in accordance with AC 43.13-2B, Chapter 2.
- 2) The instrument panel must be a minimum of 0.040 inches thick.
- 3) The dimensions and limitations of the hole must be as shown in Figure 4-13.
- 4) The new location must satisfy the alignment requirements shown in Figure 4-3, Figure 4-4, and Figure 4-5.
- 5) There must be at least 0.25 inches between the main instrument hole or the screw holes and any adjacent holes or the edges of the panel.
- 6) The instrument panel must be structurally capable of supporting the weight of the installed units.
- 7) The location of the hole must allow for sufficient clearance for the G5 electrical and pneumatic connections, see Figure 4-14.
- 8) The location must be free from rapid thermal transients, in particular, large heat loads from electrical loads.
- 9) Do not mount the G5 within 1 inch of magnetically mounted antennas, speaker magnets, or other strongly magnetic items.

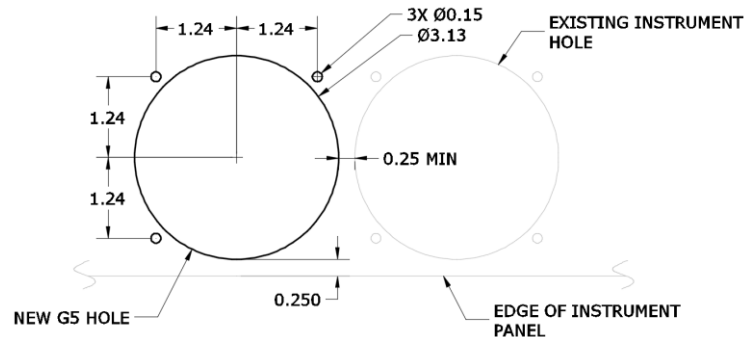

Figure 4-13, G5 Instrument Hole Dimensions

This area intentionally blank

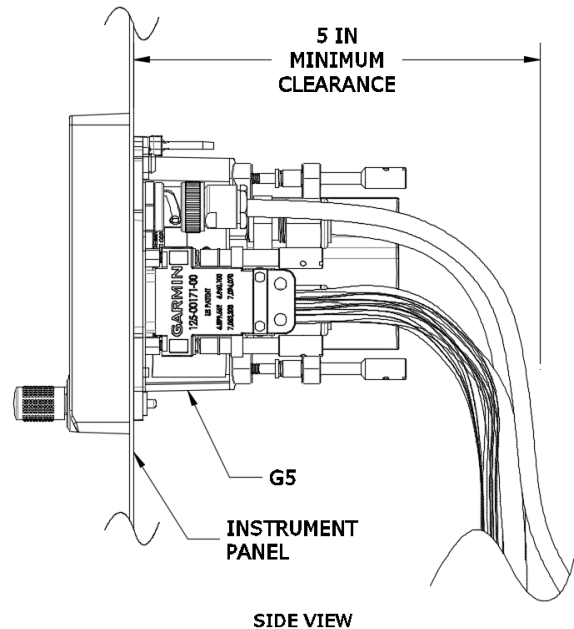

Figure 4-14, Clearance for Connections

4.1.2.6 G5 Recessed Mount Option

The G5 unit may be recessed into the instrument panel which positions the display flush with the instrument panel. A full understanding of this modification is required before starting. A recessed adapter plate and modification of the instrument panel will be needed. Some instrument panels may not be capable of supporting this modification. See section 4.1.2.6.5 for suggested adapter plate modification procedure.

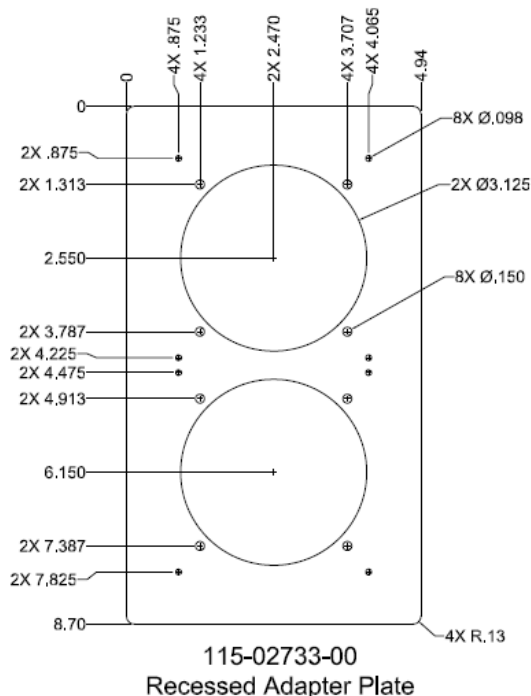

Figure 4-15 Recessed Adapter Plate

Recessed Adapter Plate, 115-02733-00, is required when a G5 unit is recessed in the panel. The plate can be ordered from Garmin, or field fabricated. If field fabricated, it must be 0.090 thick 2024-T3 aluminum per Figure 4-15 and must have some type of corrosion protection (primer, alodine, etc.). The Recessed Adapter Plate includes reference holes and can be used as a template for creating the recessed cutout.

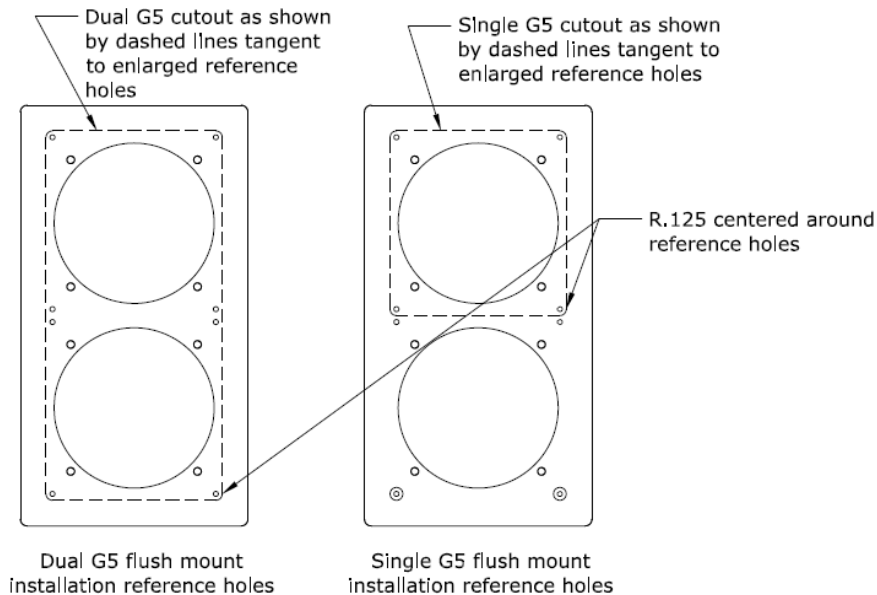

Figure 4-16 Recessed Adapter Plate Template Reference Holes

4.1.2.6.1 Recess Mounting Single G5

Install a single recessed G5 as illustrated by

Figure 4-17 and Figure 4-18. A G5 installation in the attitude position is shown, but the same instructions can be used when installing a G5 in the DG or turn coordinator positions. Modify 115-02733-00 adapter for single G5 installation per Figure 4-16. A minimum of four No. 6 MS35206-2XX screws must be used to secure the modified mounting adapter plate in place. Maintain 1.5D edge distance minimum.

This area intentionally blank

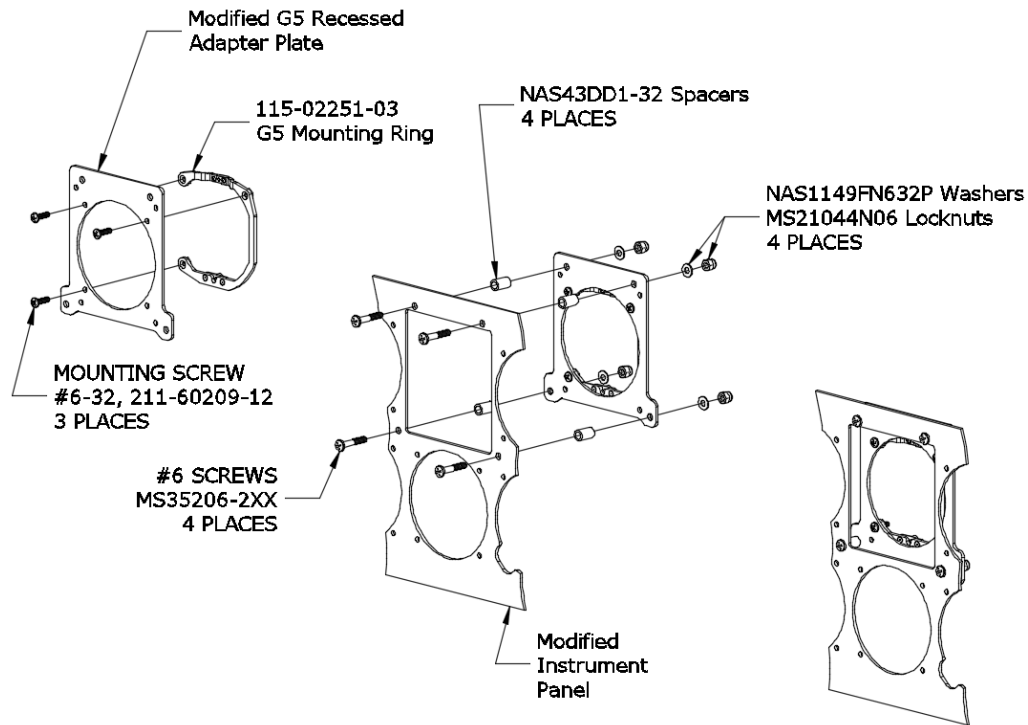

Figure 4-17 Single G5 Recessed Adapter Plate Installation

Install G5 unit per section 4.1.2.2.

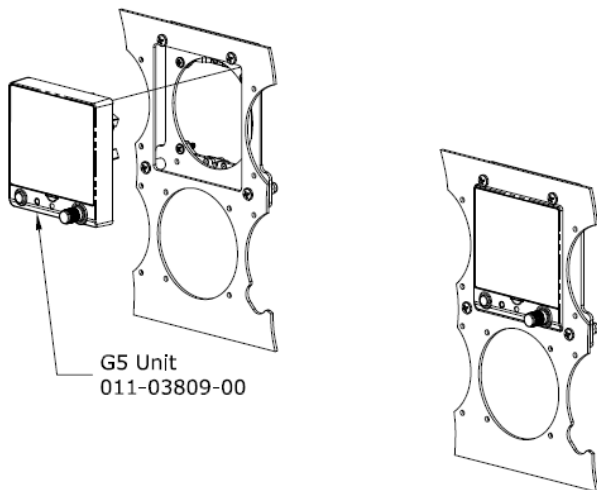

Figure 4-18 Single G5 Recessed Installation

4.1.2.6.2 Recess Mounting Dual G5 Vertically

Install dual recessed G5s as illustrated by Figure 4-19 and Figure 4-20. A minimum of six No. 6 MS35206-2XX screws must be used to secure the modified mounting adapter plate in place. Maintain 1.5D edge distance minimum.

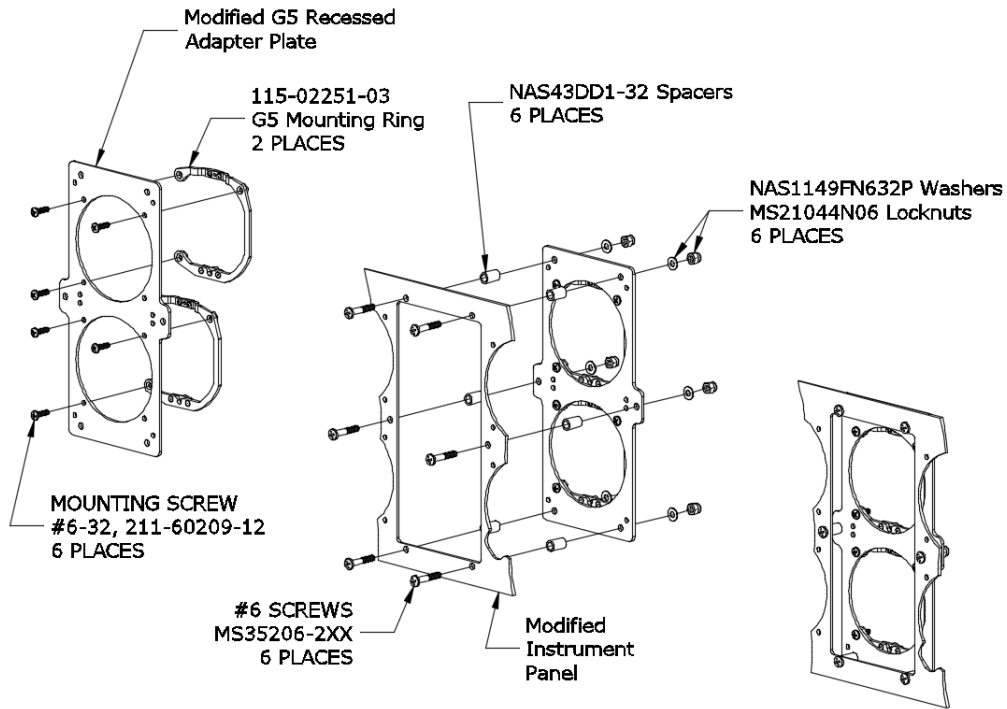

Figure 4-19 Dual Vertical G5 Recessed Adapter Plate Installation

Install G5 units per section 4.1.2.2.

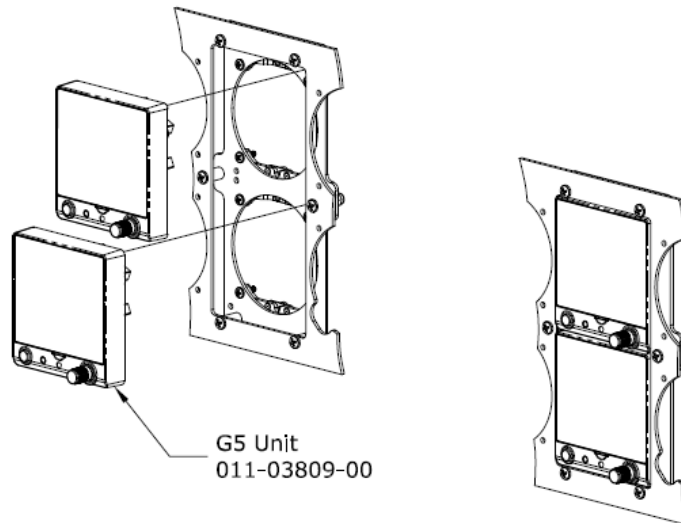
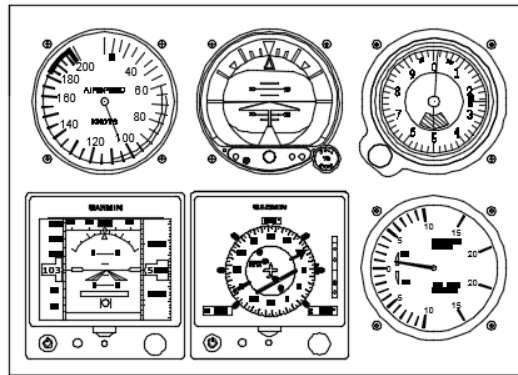

Figure 4-20 Dual Vertical G5 Recessed Installation

4.1.2.6.3 Recess Mounting Dual G5 Horizontally

In an installation where the G5 Attitude indicator is in the Turn Coordinator position and a G5 DG/HSI is installed as well (ref Figure 4-21), the dual G5s may be installed recessed horizontally in a similar manner to the dual vertical recessed installation. A horizontal recessed adapter plate will need to be field fabricated in order to fit the existing installation. This plate must be fabricated of 0.090 thick 2024-T3 aluminum and must have some type of corrosion protection (primer, alodine, etc.). A minimum of six No. 6, MS35206-2XX screws must be used to secure the modified mounting adapter plate in place. Maintain 1.5D edge distance minimum.



Turn Coordinator and
DG/HSI Position

Figure 4-21 Dual Horizontal G5 Recessed Installation

This area intentionally blank

4.1.2.6.4 Instrument Panel Modification Limitations

The modification required for recess mounting a G5, whether it is single, dual vertical or dual horizontal must meet the following conditions:

- 1) The mounting location must satisfy the alignment requirements shown in Figure 4-3, Figure 4-4, Figure 4-5.
- 2) The proposed location must allow for sufficient clearance for the G5 unit and connections as shown in Figure 4-14.
- 3) The hole must meet the limitations and minimums as shown in Figure 4-22.
- 4) The modification must be completed in accordance with AC 43.13-2B, Chapter 2.

Any modification of subsequent structure or parts other than the instrument panel as defined in these instructions are beyond the scope of this manual. Additional data from the aircraft manufacturer or other FAA approved data would be required for these situations.

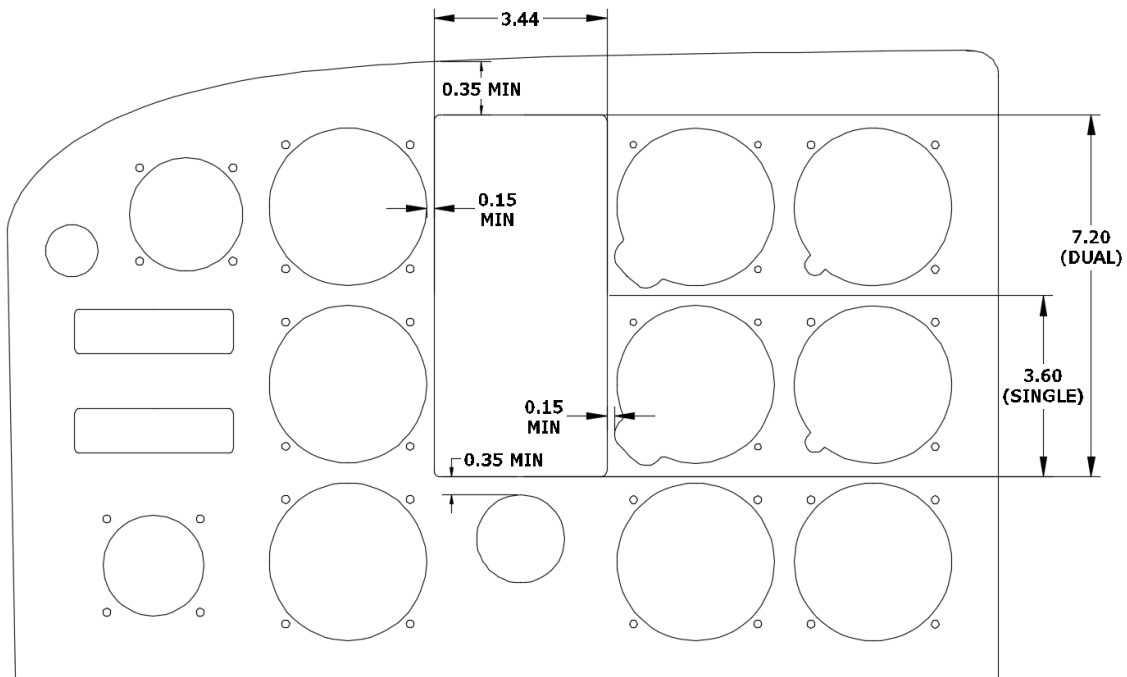

Figure 4-22, Instrument Panel Limitations

4.1.2.6.5 Modifying Recess Mount Adapter Plate

This section illustrates a suggested procedure for modifying the G5 Recessed Adapter Plate and instrument panel. Dual vertical G5 installation shown; dual horizontal and single installation procedure is similar.

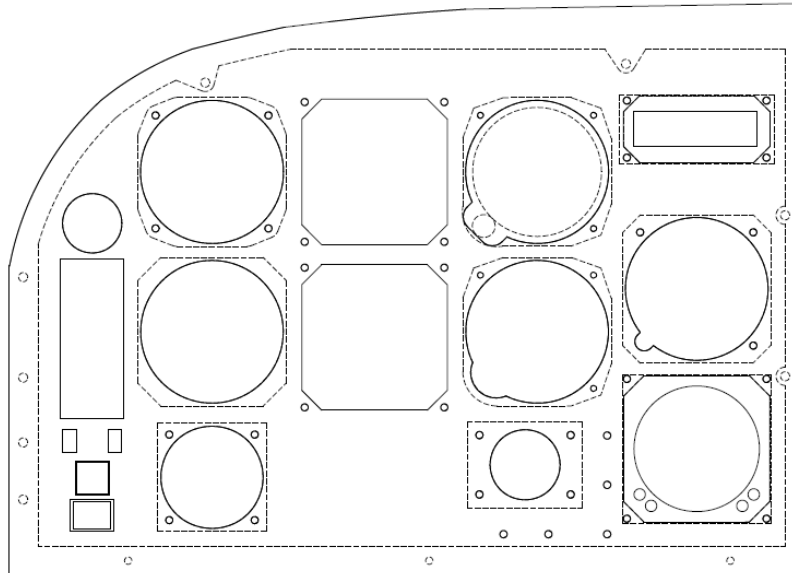

Figure 4-23 Instrument Panel; View looking forward

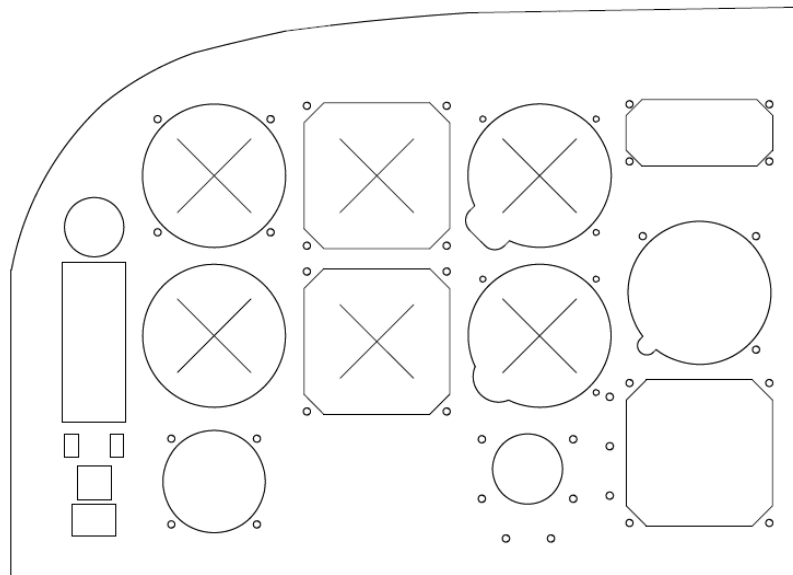

Figure 4-24 Instrument Panel view with instruments removed

Temporarily remove instruments adjacent to proposed G5 location and/or as needed.

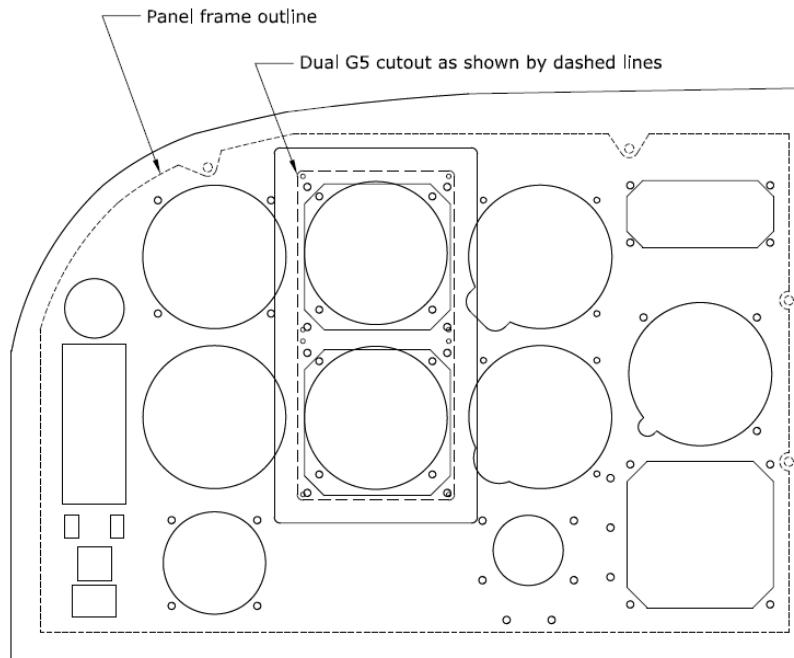

Figure 4-25 Recessed Adapter Plate located on panel

Place 115-02733-00, Recessed Adapter Plate, at desired location, keeping in mind distance to instrument panel frame and other instruments.

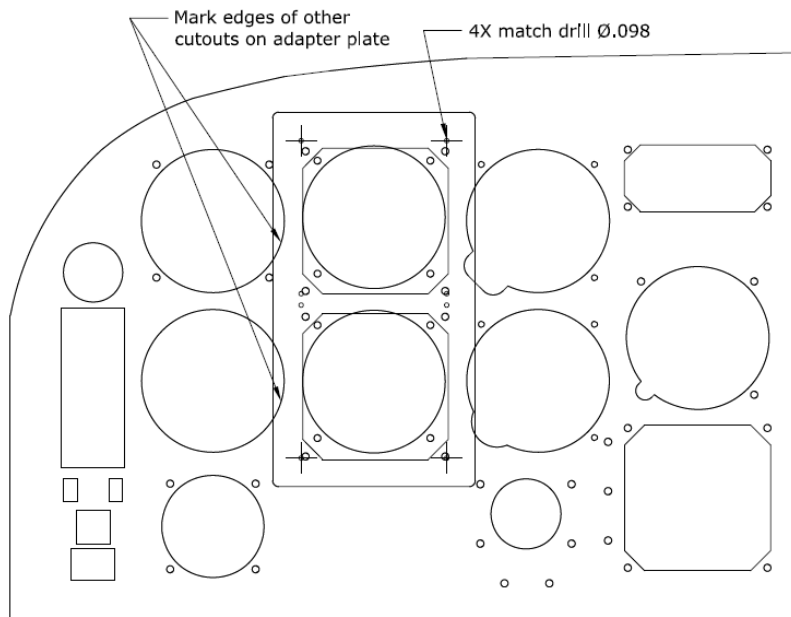

Figure 4-26 Match drilling through panel, using adapter plate as template

When ready, mark adapter plate and match drill instrument panel 4x, .098 diameter through adapter plate reference holes

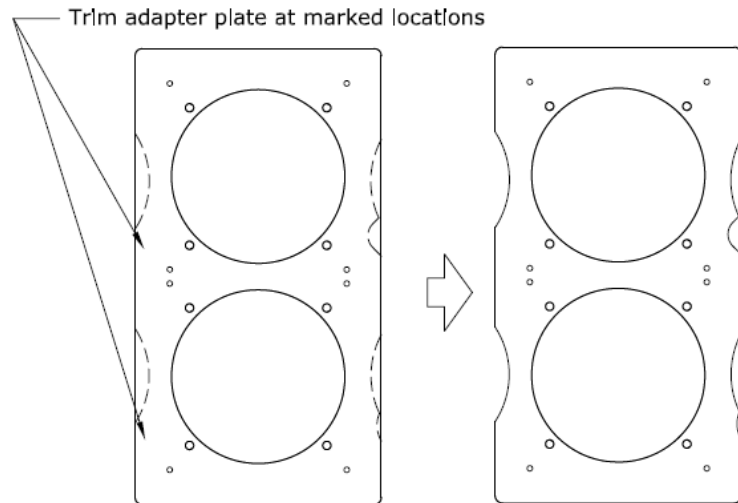

Figure 4-27 Preliminary trimming of adapter plate

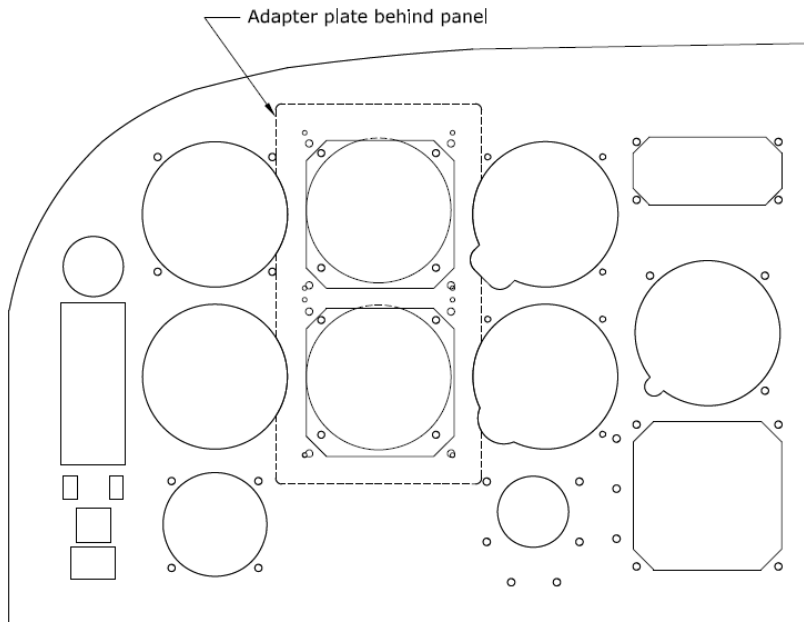

Figure 4-28 Adapter plate located on far side of instrument panel

Use reference holes from adapter plate to align adapter plate behind panel.

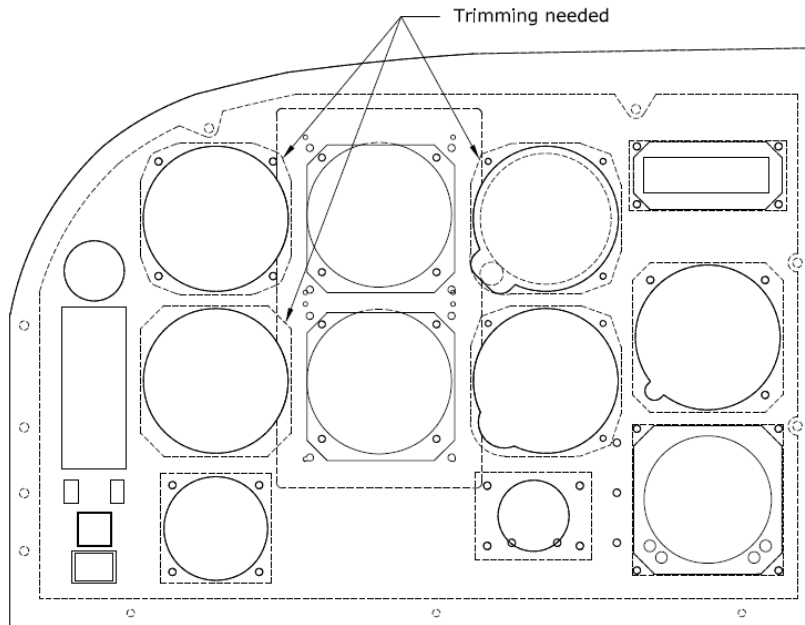

Figure 4-29 Additional trimming of adapter plate required

Mark adapter plate where trimming is needed in order to avoid interference with any adjacent instrument or other item.

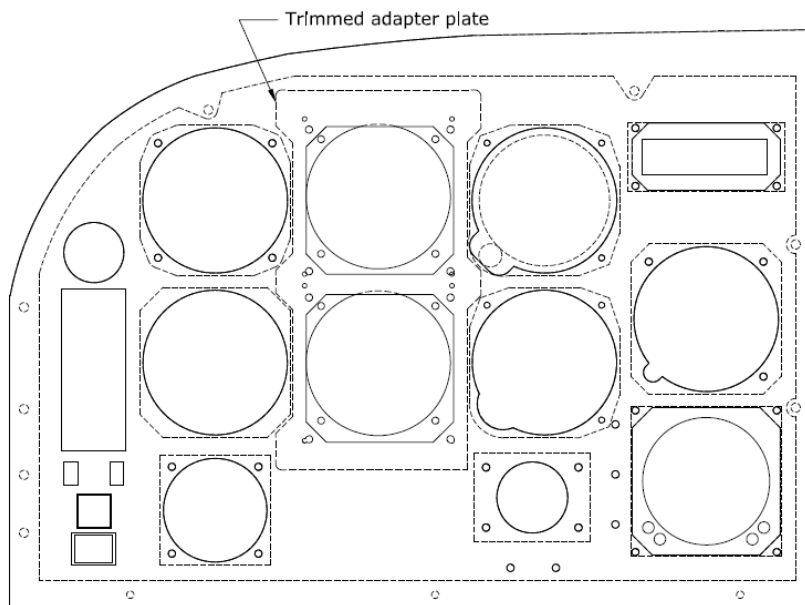

Figure 4-30 Trimmed adapter plate

Trim adapter plate as needed; remove only enough material to allow adapter plate to fit without interference.

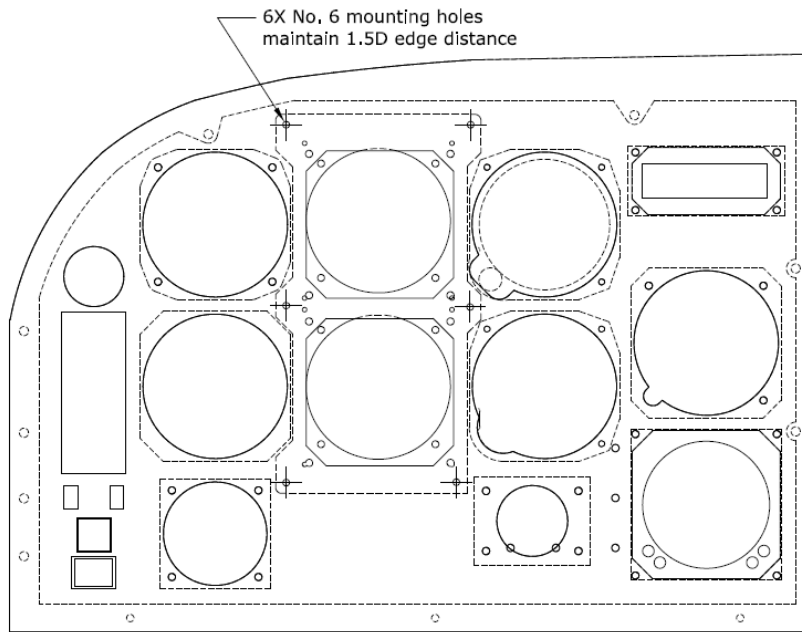

Figure 4-31 Adapter plate mounting holes

Drill 6 mounting holes through both adapter plate and panel; maintain minimum 1.5D edge distance for No. 6 hardware.

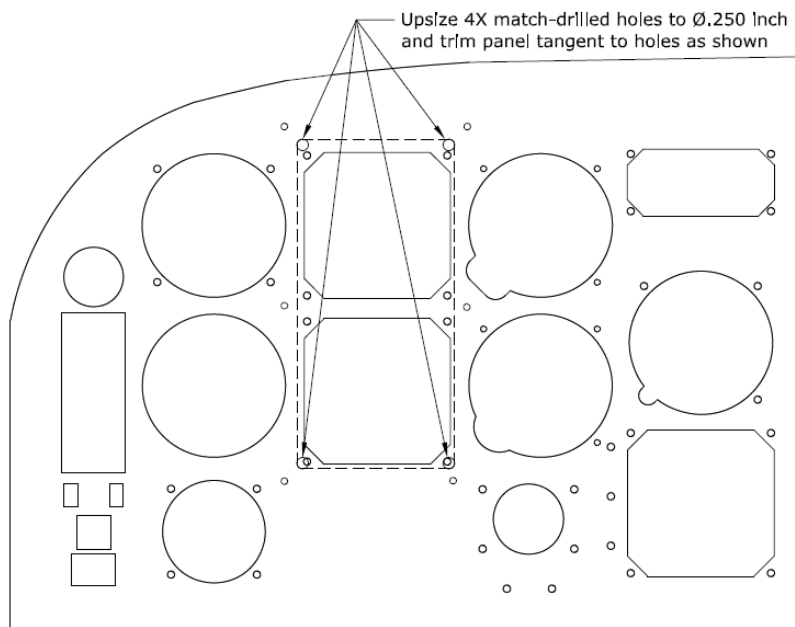

Figure 4-32 Dual G5 panel cutout, using match drilled holes for reference

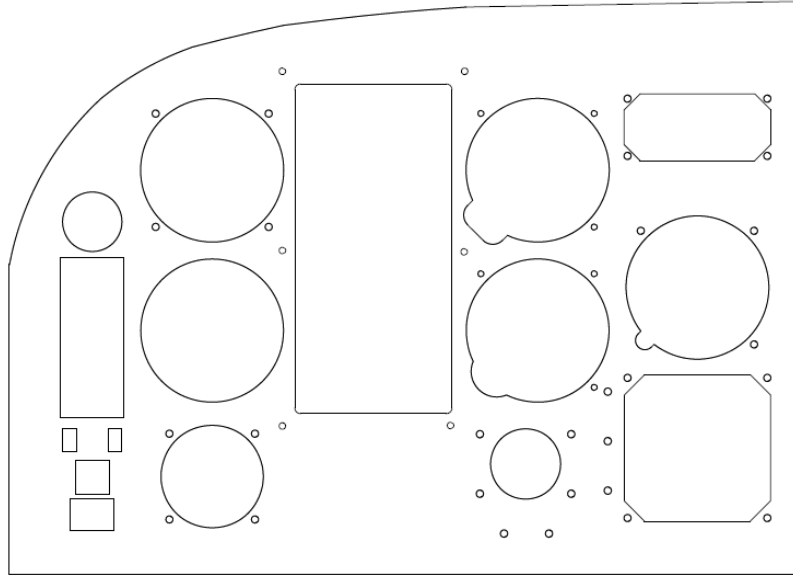

Figure 4-33 Instrument panel after cutout for dual vertical G5 units

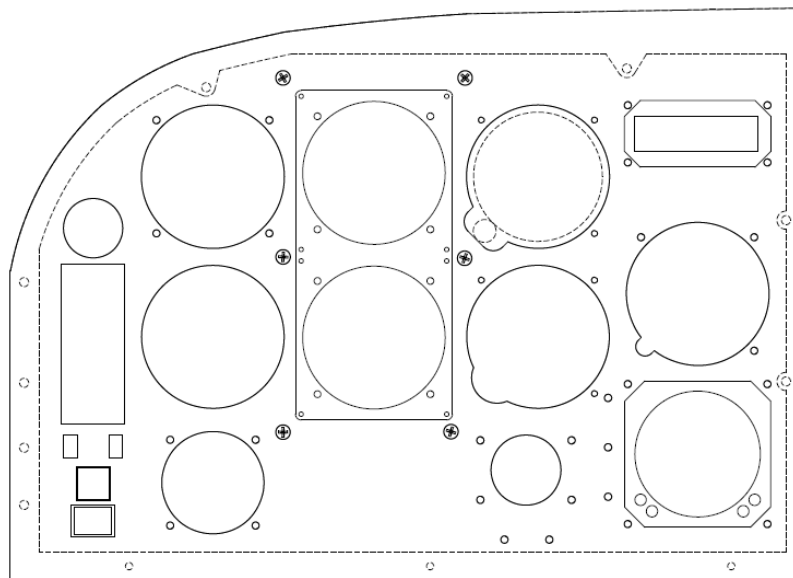

Figure 4-34 Adapter plate installed

Deburr and finish instrument panel and adapter plate as needed, then install adapter plate per Section 4.1.2.6.1 or Section 0.

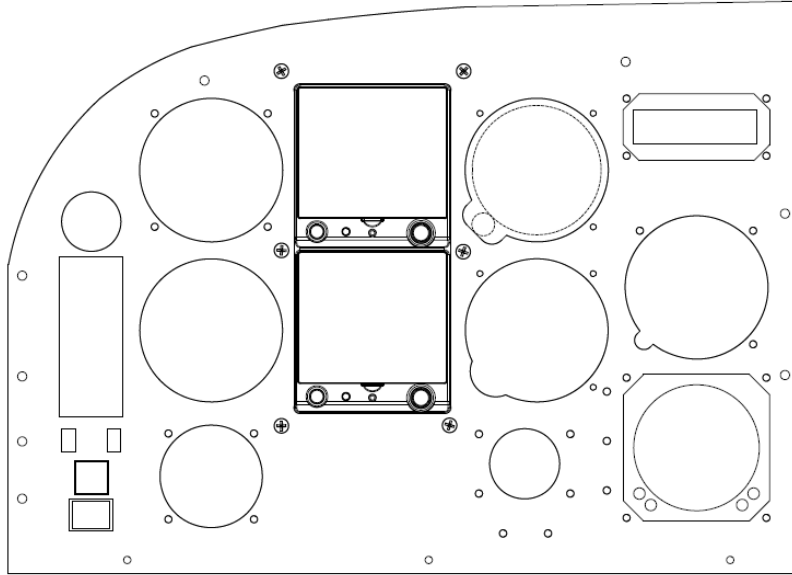

Figure 4-35 Dual vertical G5 units installed

Install G5 units per Section 4.1.2.2.

This area intentionally blank

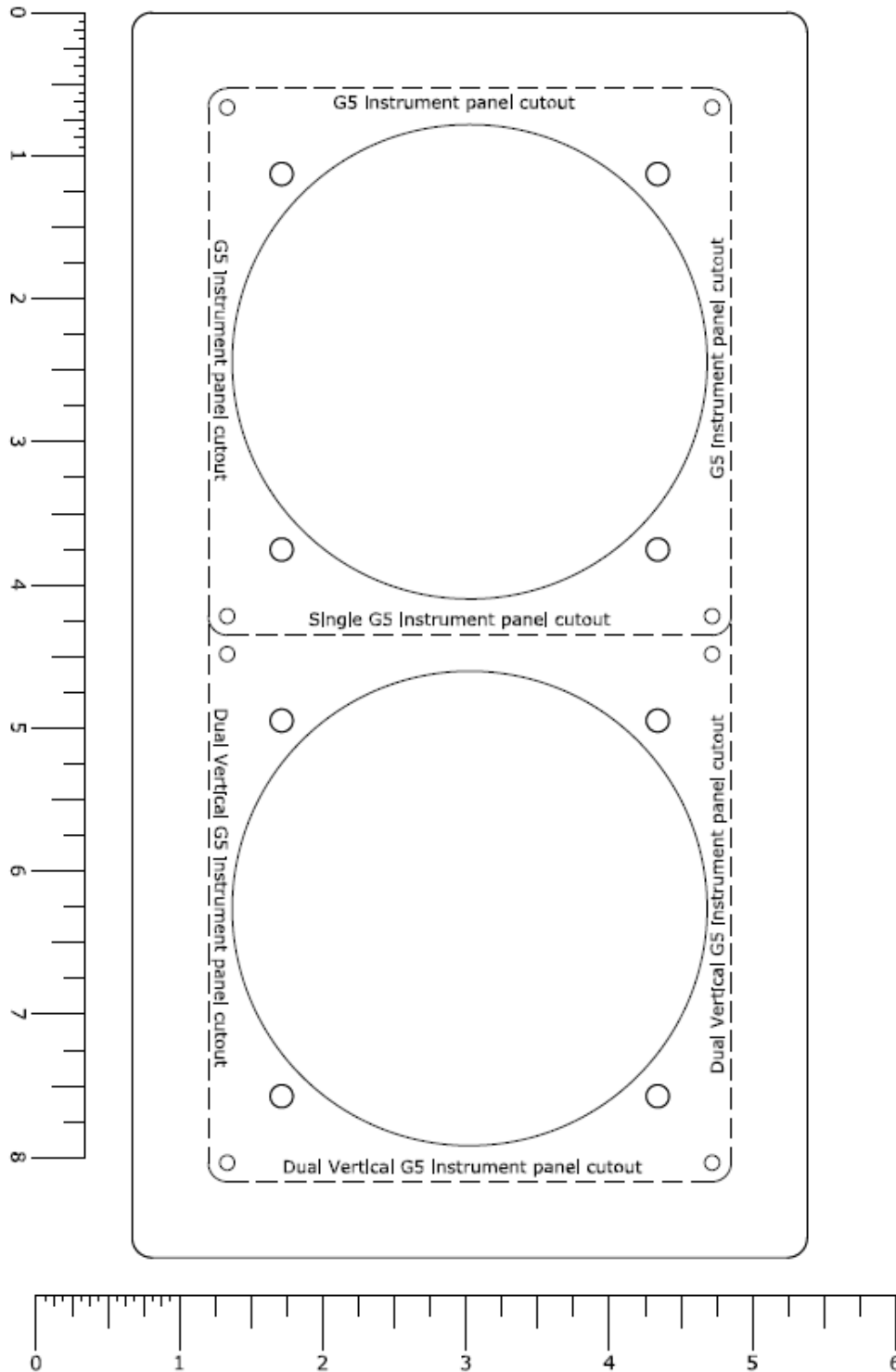

Figure 4-36 G5 flush mount adapter plate printable template

The figure above may be photocopied and scaled as needed to match the full size part. This paper copy may be used along with the instructions on Section 4.1.2.6.5 to verify the proposed installation of the G5 units will meet the installation requirements.

4.1.2.7 GMU 11 Magnetometer Mounting Requirements

The GMU 11 is an extremely sensitive magnetic sensor, more sensitive to magnetic disturbances than a flux gate magnetometer. For this reason, when choosing a location, distance from possible magnetic disturbances is critical to a successful installation.

Consider the following items when choosing a mounting location:

- Maintain as much distance as possible from electric motors, ferromagnetic materials, electrical devices drawing more than 100 mA and electrical conductors
- Ensure that any electrical conductor near the GMU 11 is shielded
- The GMU 11 must not be mounted on an access panel
- Mounting of the GMU 11 in the wing is preferred



CAUTION

After a location has been selected and a GMU 11 mounting method chosen, a location survey must be performed at that location prior to fabricating or assembling any parts for the GMU 11 mounting. It is possible that the location will fail the survey and the installation will require a new location, with different installation requirements. See Section 4.1.2.8 for Magnetic Interference Survey instructions.



CAUTION

Failure to meet these specifications may result in a failed magnetometer calibration.

For the installation of the GMU 11 level the aircraft in both the longitudinal and lateral axes. Refer to the aircraft's maintenance manual for leveling instructions. It is preferred that the aircraft is placed on jacks while leveled to avoid inadvertently placing the aircraft in a non-level position when entering, exiting or working the aircraft.

The GMU 11 should be mounted to a surface known to have sufficient structural integrity to withstand additional inertial forces imposed by the 0.26-pound unit.

In order to satisfy the structural mounting requirements for the GMU 11, the following conditions must be met:

- 1) The mounting location must satisfy the alignment requirements shown in Figure 4-37 and Figure 4-38
- 2) The mounting structure, existing or new, must be electrically bonded to the airframe per Section 4.6.
- 3) Any supporting structure must be rigidly connected to the aircraft primary structure through strong structural members capable of supporting substantial loads.
- 4) Mounting platform shall not span greater than 12" in width or length without direct attachment to primary structure. If mounting platform does span greater than 12", add necessary stringers, doublers, bulkhead flange reinforcements, etc., to provide adequate support. Existing honeycomb core sandwich panels with aluminum face sheets are adequate and do not require additional reinforcement.
- 5) A minimum of 3" between the connector end of the GMU 11 and any object must be maintained to ensure clearance for connector and wire harness.
- 6) If a support bracket or shelf needs to be fabricated, it should be fabricated and attached to the aircraft structure in accordance with the methods outlined in AC43.13-2B Chapter 1 and 2, AC43.13-1B Chapter 4, and the following requirements:
 - a) Material shall be 2024-T3 aluminum alloy sheet per AMS-QQ-A-250/4 or Clad 2024-T3 aluminum alloy sheet per AMS-QQ-A-250/5.

- b) Material shall be minimum 0.032 inch thick.
- c) Material shall have some type of corrosion protection (primer, alodine, etc.)
- d) It shall be attached to primary aircraft structure with a minimum of 4 non-magnetic fasteners or rivets from Table 4-1.

Table 4-1 GMU 11 Supporting Hardware

Hardware	Minimum Specifications
Rivets	MS20470AD3-X (3/32 Diameter, Length A/R)
Screws	MS51957-XX (#6-32, Stainless Steel, Length A/R)
Washers	NAS1149CN632R (#6-32, Stainless Steel)
Nuts	MS21044C06 (#6-32, Stainless Steel)

In general, wing mounting of the GMU 11 magnetometer is preferred. Fuselage mounting is permitted, but NOT within two feet of the cabin area because of numerous potential disturbances that can interfere with accurate operation. The GMU 11 must be mounted in a serviceable location in the aircraft (e.g., accessible through an access panel).

The GMU 11 must be oriented with the mounting flanges facing down to within 3.0° of the aircraft pitch and roll axis as show in Figure 4-37.

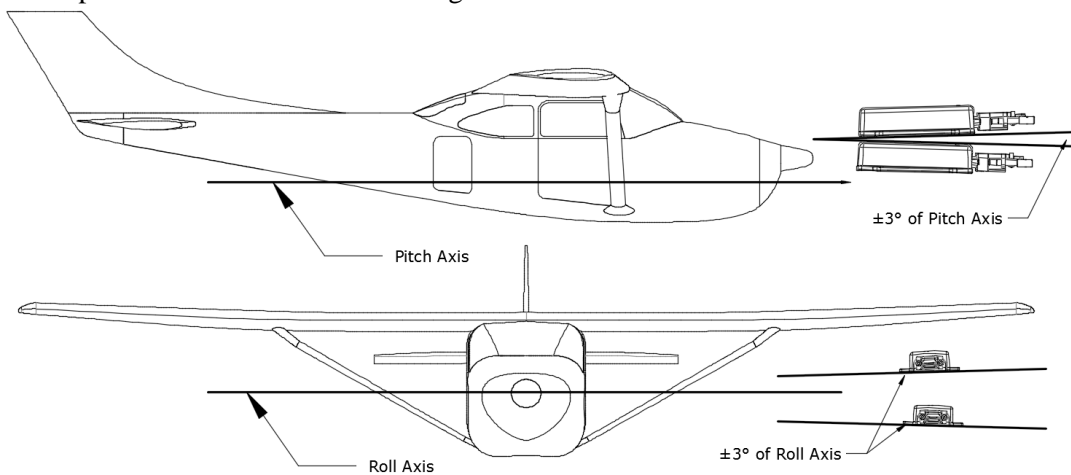

Figure 4-37 GMU 11 Pitch and Roll Requirements

This area intentionally blank

Lateral orientation can be such that the connector faces forward, aft, left or right, but must be within 2° of the longitudinal axis of the aircraft, see Figure 4-38.

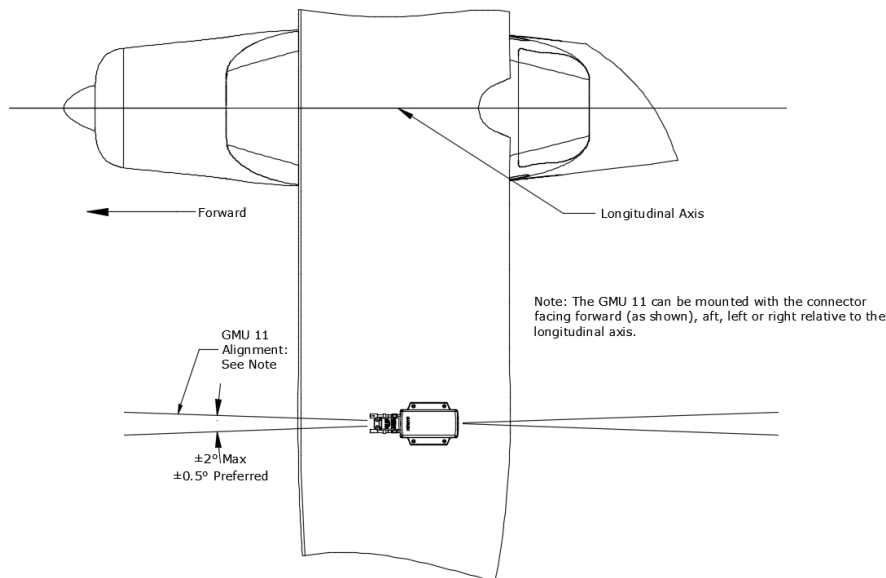

Figure 4-38 GMU 11 Heading Alignment Requirements

4.1.2.8 Magnetic Interference Survey

1. Temporarily place the GMU 11 in the proposed mounting location maintaining orientation as described in Figure 4-37 and Figure 4-38.
2. Secure in place using tape if needed. Do not use clamps or other devices that are ferrous or magnetic.
3. Run the magnetic interference survey in accordance with APPENDIX C. If the survey passes, the location is considered reliable for the installation of the GMU 11.

If the test fails, the location should be considered unreliable until the source of the magnetic interference is identified, remedied and the location is retested and passes the test. If the magnetic interference cannot be remedied, another location should be chosen and tested.

This area intentionally blank

4.1.2.9 GMU 11 Mounting



CAUTION

Care should be taken when tightening the mounting screws of the GMU 11. Excessive tightening may damage the mounting flange or break the screws. Fasteners should be tightened until snug, plus one-quarter turn.

GMU should not be mounted in a composite wing.

It may be mounted in a wing constructed of metal so long as any hardware used to attach the GMU or its bracket do not penetrate the fuel tank. For installation in a composite wing tip, of a metal wing, see APPENDIX D.

Using the hardware called out in Figure 4-39, mount the GMU 11, and replace any magnetic fasteners within 1.5 feet with nonmagnetic equivalents (e.g. replace zinc-plated steel screws used to mount wing covers or wing tips with nonmagnetic stainless steel screws).

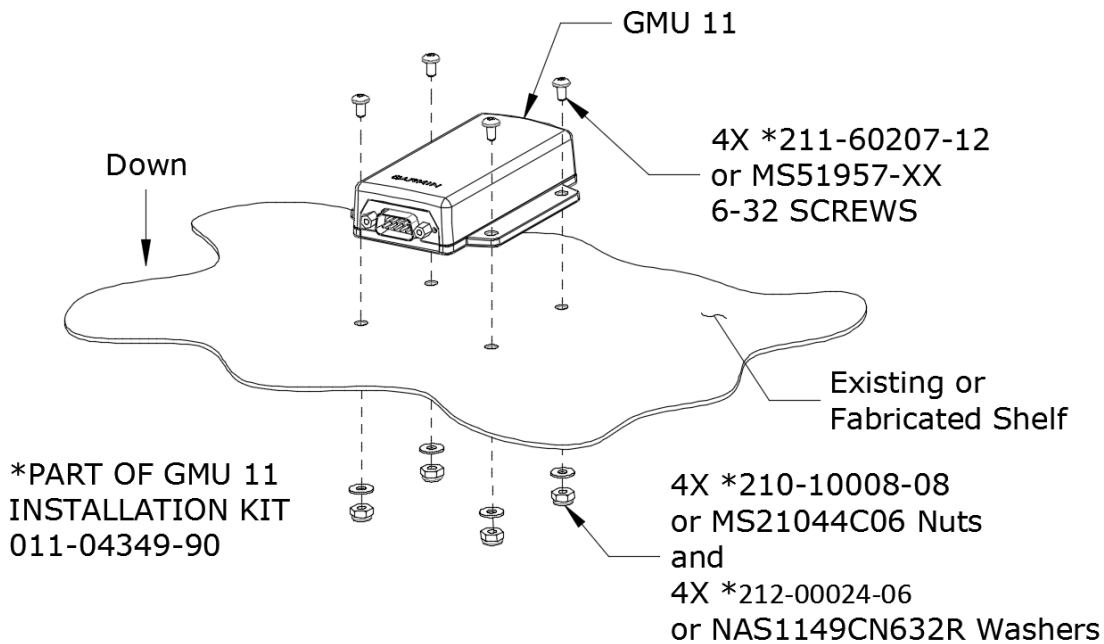

Figure 4-39 GMU 11 Mounting Hardware



4.1.3 GAD 29/29B Mounting Requirements

The GAD 29/29B should be mounted to a surface known to have sufficient structural integrity to withstand additional inertial forces imposed by the 0.63-pound unit.

In order to satisfy the structural mounting requirements for the GAD 29/29B, the following conditions must be met:

- 1) The mounting structure, existing or new, must be electrically bonded to the airframe per Section 4.6.
- 2) Any supporting structure must be rigidly connected to the aircraft primary structure through strong structural members capable of supporting substantial loads.
- 3) Mounting platform shall not span greater than 12" in width or length without direct attachment to primary structure. If mounting platform does span greater than 12", add necessary stringers, doublers, bulkhead flange reinforcements, etc., to provide adequate support. Existing honeycomb core sandwich panels with aluminum face sheets are adequate and do not require additional reinforcement.
- 4) A minimum of 3" between the connector end of the GAD 29/29B and any object must be maintained to ensure clearance for connectors and wire harness.
- 5) If a support bracket or shelf needs to be fabricated, it should be fabricated and attached to the aircraft structure in accordance with the methods outlined in AC43.13-2B Chapter 1 and 2, AC43.13-1B Chapter 4, and the following requirements:
 - a) Material shall be 2024-T3 aluminum alloy sheet per AMS-QQ-A-250/4 or Clad 2024-T3 aluminum alloy sheet per AMS-QQ-A-250/5.
 - b) Material shall be minimum 0.040 inch thick.
 - c) Material shall have some type of corrosion protection (primer, alodine, etc.)

It shall be attached to primary aircraft structure with a minimum of 4 fasteners or rivets listed in Table 4-2.

Table 4-2 GAD 29/29B Supporting Hardware

Hardware	Minimum Specifications
Rivets	MS20470AD3-X (3/32 Diameter, Length A/R)
Screws	MS35206-XXX (#6-32, Length A/R)
Washers	NAS1149FN632P
Nuts	MS21042L06

Using the hardware called out in Figure 4-40, mount the GAD 29/29B to the chosen mounting location. Recommended torque of fasteners is 20-25 in-lbs.

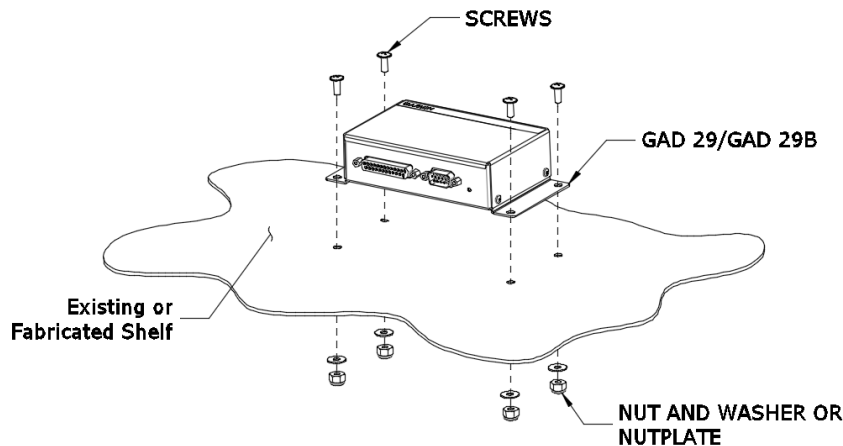

Hardware Specifications

SCREWS	AN525832RXX (8-32 LENGTH A/R)			
WASHERS	NAS1149FN816P	OR	#8 NUTPLATES	STANDARD PART; ANY MS (MILITARY SPECIFICATION) PART NUMBER
NUTS	MS21044N08		RIVETS	MS20426AD3-X

Figure 4-40 GAD 29/29B Mounting Hardware

4.1.3.1 GAD 29B Transformer Mounting Instructions

For GAD 29B installations interfacing with certain Century and Cessna autopilots an inline transformer may be required. Refer to Section 5.12 for further information on specific autopilots.

Solder transformer leads to the appropriate wire per SAE AS4461, and cover with heat shrink that extends the entire lead of the transformer and at least 0.5 inch of the insulated wire. Do this for each transformer lead and then cover the entire assembly with heat shrink, extending at least 1 inch past the solder connections.

This assembly must then be secured to the existing aircraft wiring harness near the GAD 29B to reduce strain on the components. Secure using a minimum of two cable ties, one over the body of the transformer and one near the solder joints.

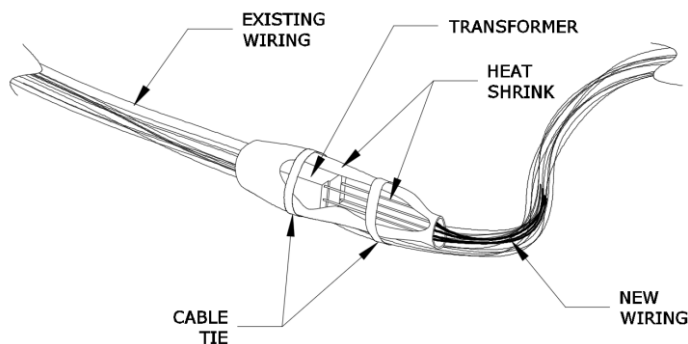

Figure 4-41 GAD 29B Inline Transformer Mounting Instructions



4.1.4 Pneumatic Connections

The G5 Attitude indicator and G5 DG/HSI use pitot and static pressure for the secondary display of altitude and airspeed. The installer must install the necessary hoses and fittings to interface to the existing aircraft pitot and static pressure source. Below are guidelines to use for this installation.

The G5 has two ports that are connected to the aircraft's pitot and static pressure sources. The ports are labeled on the unit using the abbreviations "P" and "S" respectively (Figure 6-9). The pressure ports have 1/8-27 ANPT female threads. The mating fitting must have 1/8-27 ANPT male threads.

Determine the hose/connection material that best interfaces with the existing aircraft installation. Reference the appropriate aircraft parts manual to determine the current part numbers associated with the aircraft installation of hose and connections used in the pitot/static system.

Use appropriate tubing and fittings to connect the pitot and static lines to the unit. Avoid sharp bends in the tubing and route hoses clear of aircraft control cables. The G5 must not be at the low point of the pneumatic plumbing lines to avoid moisture or debris collecting at or near the unit. Ensure that no deformations of the airframe surface have been made that would affect the relationship between static air pressure and true ambient static air pressure for any flight condition. Refer to 14 CFR Part 43, Appendix E and AC43.13-1B, Chapter 12, Section 4 for approved practices while installing hoses and connections. If this static source had an alternate static source selector switch, it must be retained.

For aircraft equipped with a single pitot-static system, the G5 must be connected to the pitot-static system used by the pilot's instruments. For aircraft equipped with a dual pitot-static system, the G5 must be connected to the pitot-static system that is independent from the pilot's instruments.



CAUTION

To avoid damaging the G5 pressure sensors, both the pitot and static ports must be connected to the test set.



CAUTION

Verify sealant/tape is not present inside the plumbing upon assembly. Use care to avoid getting fluids or particles inside the pneumatic lines or G5 ports.

This area intentionally blank



4.2 Antenna Cable Installation and Connections



NOTE

GPS antenna cable loss must be between 1.5 dB and 6.5 dB in order to maintain proper rejection of interference signals. If RG-142B or RG-400 is used it must be between 6.5 and 35 feet long to meet the cable loss requirement. For longer lengths, use low-loss double or triple-shielded, 50 Ω coaxial cable.

Proper selection of coaxial cable and assembly of connectors is critical to GPS signal performance. Use a TNC connector, AMP P/N 31-4452, to connect the coaxial cable to the GPS antenna. Use a BNC connector, AMP P/N 225395-6, to connect the coaxial cable to the G5.

Additional loss from coaxial connectors and adapters, such as TNC to BNC, should be considered when computing cable loss. A typical loss of 0.2 dB can be used for each connection.

For very short runs, where the loss is less than 1.5 dB, additional cable should be used to increase the loss to within 1.5 dB and 6.5 dB. This additional cable may be coiled, taking into account the minimum bend radius of the cable.

4.2.1 Coaxial Cable Termination

Follow the steps below for installation of coaxial cables:

- Secure the cable in accordance with AC 43.13-1B chapter 11, section 11.
- Trim the coaxial cable to the desired length.
- Install the TNC or BNC connectors per the manufacturer's instructions.

This area intentionally blank



4.3 Electrical Installation

4.3.1 Special Tools

Crimp tools and positioners are required to ensure consistent, reliable crimp contact connections for the D-sub connectors. The following crimp tools are recommended:

Table 4-3: Contact Crimp Tooling

Manufacturer	Crimp Tool P/N	Positioner P/N	Insertion/Extraction Tool P/N
MIL-Spec	M22520/2-01	M22520/2-08	M81969/1-02
Daniels	AFM8	K13-1	

4.3.2 Power Distribution

The circuit protection device for the G5 and GAD 29/29B must be a push-pull manually resettable circuit breaker or identically rated circuit protection device approved by the aircraft type certificate. See Section 3.2.1 for required circuit breaker part numbers. The G5 must be connected to the battery bus to supply power. (Note: some aircraft manufacturers may label the battery bus as “essential bus” or “main bus”).

4.3.3 Wiring Harness Assembly

Allow adequate space for installation of the wiring harness and connectors. Construct the wiring harness in accordance with the information contained in this and the following sections. Mark wire in accordance with AC 43.13-1B Chapter 11 Section 16. Strip and insert the wire into the contact and crimp with the recommended (or equivalent) crimping tools. Insert the contacts into the connector as specified by the interconnect diagrams in Section 5. Verify the contacts are properly engaged into the connector by gently tugging on the wire. Mark harness connectors in accordance with AC 43.13 Chapter 11 Section 17. Route and secure the wiring harness away from sources of electrical interference.

The tables below lists the parts required to complete the assembly of the G5, GMU 11 and GAD 29/29B wiring harness connectors. Some of the parts required for this installation are included in the connector kit, and some are to be provided by the installer. See the notes below the tables for parts that are included in the connector kit. The Garmin connector backshell gives the installer the ability to easily terminate shield grounds at the connector backshell as shown in and Figure 4-43. Numbers referenced in Figure 4-42 and Figure 4-43 correspond to items listed in Table 4-4, Table 4-5, and Table 4-6.



Table 4-4: G5 (1P51, 2P51) and GMU11 (P111) Connector Parts

Item	Description	Part Number	Notes
1	Shield Termination, Solder Style, Insulated, Heat-Shrinkable, Environment Resistant (X = size)	AS83519/1-X (SAE-AS83519)	1
2	Contact, Socket, MIL Crimp, Size 20	M39029/63-368, or	
		336-00022-02	2
3	Insulation Tape, Electrical, Self-Adhering, Unsupported Silicone Rubber	A-A-59163 (MIL-I-46852C)	
4	Terminal, Lug, Crimp Style, Copper, Insulated, Ring Tongue, Bell Mouthed, Type II, Class I	MS25036-149	
5	Connector, Plug, D-Sub, MIL Crimp Socket	330-00625-09	2
6	Backshell, Jackscrew, 9/15 Pin	125-00171-00	2
7	Clamp, Backshell, Jackscrew, 9/15 Pin	115-01078-00	2
8	Screw, 4-40x.375, PHP, SS/P, w/Nylon	211-60234-10	2
9	Cover, Backshell, Jackscrew, 9/15 Pin	115-01079-00	2
10	Screw, 4-40x.187, FLHP100, SS/P, w/Nylon	211-63234-06	2
11	Screw, PHP, 8-32 x 0.312", Cad-Plated Steel, or Screw, PHP, 8-32 x 0.312", Stainless	MS35206-242, or MS51957-42	
12	Split Washer, #8 (0.045" compressed thickness), Cad-plated Steel, or Split Washer, #8 (0.045" compressed thickness), Stainless	MS35338-42, or	
		MS35338-137	
13	Flat washer, Cad-plated Steel, #8, 0.032" thick, □0.174" ID, 0.375" OD, or Flat Washer, Stainless, #8, 0.032" thick, 0.174" ID, □0.375" OD	NAS1149FN832P, or NAS1149CN832R	
14	Flat Braid, 1/16"	AA59569F36T0062	1

Notes:

1. A preferred solder sleeve is the TE Connectivity/Raychem S02 series. These solder sleeves come with a pre-installed shield drain. For detailed instructions on product use, refer to TE Connectivity/Raychem process standard RCPS-100-70.
2. Garmin Part Number. Included in kit p/n 011-03002-00.

This area intentionally blank



Table 4-5: GAD 29/29B 9-pin (P291) Connector Parts

Item	Description	Part Number	Notes
1	Shield Termination, Solder Style, Insulated, Heat-Shrinkable, Environment Resistant (X = size)	AS83519/1-X (SAE-AS83519)	1
2	Contact, Socket, MIL Crimp, Size 20	M39029/63-368, or	
		336-00022-02	2
3	Insulation Tape, Electrical, Self-Adhering, Unsupported Silicone Rubber	A-A-59163 (MIL-I-46852C)	
4	Terminal, Lug, Crimp Style, Copper, Insulated, Ring Tongue, Bell Mouthed, Type II, Class I	MS25036-149	
5	Connector, Plug, D-Sub, MIL Crimp Socket	330-00625-09	2
6	Backshell, Jackscrew, 9/15 Pin	125-00171-00	2
7	Clamp, Backshell, Jackscrew, 9/15 Pin	115-01078-00	2
8	Screw, 4-40x.375, PHP, SS/P, w/Nylon	211-60234-10	2
9	Cover, Backshell, Jackscrew, 9/15 Pin	115-01079-00	2
10	Screw, 4-40x.187, FLHP100, SS/P, w/Nylon	211-63234-06	2
11	Screw, PHP, 8-32 x 0.312", Cad-Plated Steel, or Screw, PHP, 8-32 x 0.312", Stainless	MS35206-242, or MS51957-42	
12	Split Washer, #8 (0.045" compressed thickness), Cad-plated Steel, or Split Washer, #8 (0.045" compressed thickness), Stainless	MS35338-42, or	
		MS35338-137	
13	Flat washer, Cad-plated Steel, #8, 0.032" thick, □0.174" ID, 0.375" OD, or Flat Washer, Stainless, #8, 0.032" thick, 0.174" ID, □0.375" OD	NAS1149FN832P, or	
		NAS1149CN832R	
14	Flat Braid, 1/16"	AA59569F36T0062	1

Notes:

1. A preferred solder sleeve is the TE Connectivity/Raychem S02 series. These solder sleeves come with a pre-installed shield drain. For detailed instructions on product use, refer to TE Connectivity/Raychem process standard RCPS-100-70.
2. Garmin Part Number. Included in kit p/n 011-03271-00.

This area intentionally blank



Table 4-6: GAD 29/29B 25-pin (P292) Connector Parts

Item	Description	Part Number	Notes
1	Shield Termination, Solder Style, Insulated, Heat-Shrinkable, Environment Resistant (X = size)	AS83519/1-X (SAE-AS83519)	1
2	Contact, Pin, MIL Crimp, Size 20	M39029/64-369, or	
		336-00024-00	2
3	Insulation Tape, Electrical, Self-Adhering, Unsupported Silicone Rubber	A-A-59163 (MIL-I-46852C)	
4	Terminal, Lug, Crimp Style, Copper, Insulated, Ring Tongue, Bell Mouthed, Type II, Class I	MS25036-149	
5	Connector, Plug, D-Sub, MIL Crimp Socket	330-00625-09	2
6	Backshell, Jackscrew, 9/15 Pin	125-00173-00	2
7	Clamp, Backshell, Jackscrew, 9/15 Pin	115-01078-02	2
8	Screw, 4-40x.375, PHP, SS/P, w/Nylon	211-60234-10	2
9	Cover, Backshell, Jackscrew, 9/15 Pin	115-01079-02	2
10	Screw, 4-40x.187, FLHP100, SS/P, w/Nylon	211-63234-06	2
11	Screw, PHP, 8-32 x 0.312", Cad-Plated Steel, or Screw, PHP, 8-32 x 0.312", Stainless	MS35206-242, or MS51957-42	
12	Split Washer, #8 (0.045" compressed thickness), Cad-plated Steel, or Split Washer, #8 (0.045" compressed thickness), Stainless	MS35338-42, or	
		MS35338-137	
13	Flat washer, Cad-plated Steel, #8, 0.032" thick, □0.174" ID, 0.375" OD, or Flat Washer, Stainless, #8, 0.032" thick, 0.174" ID, □0.375" OD	NAS1149FN832P, or	
		NAS1149CN832R	
14	Flat Braid, 1/16"	AA59569F36T0062	1

Notes:

1. A preferred solder sleeve is the TE Connectivity/Raychem S02 series. These solder sleeves come with a pre-installed shield drain. For detailed instructions on product use, refer to TE Connectivity/Raychem process standard RCPS-100-70.
2. Garmin Part Number. Included in kit p/n 011-03271-00.

This area intentionally blank

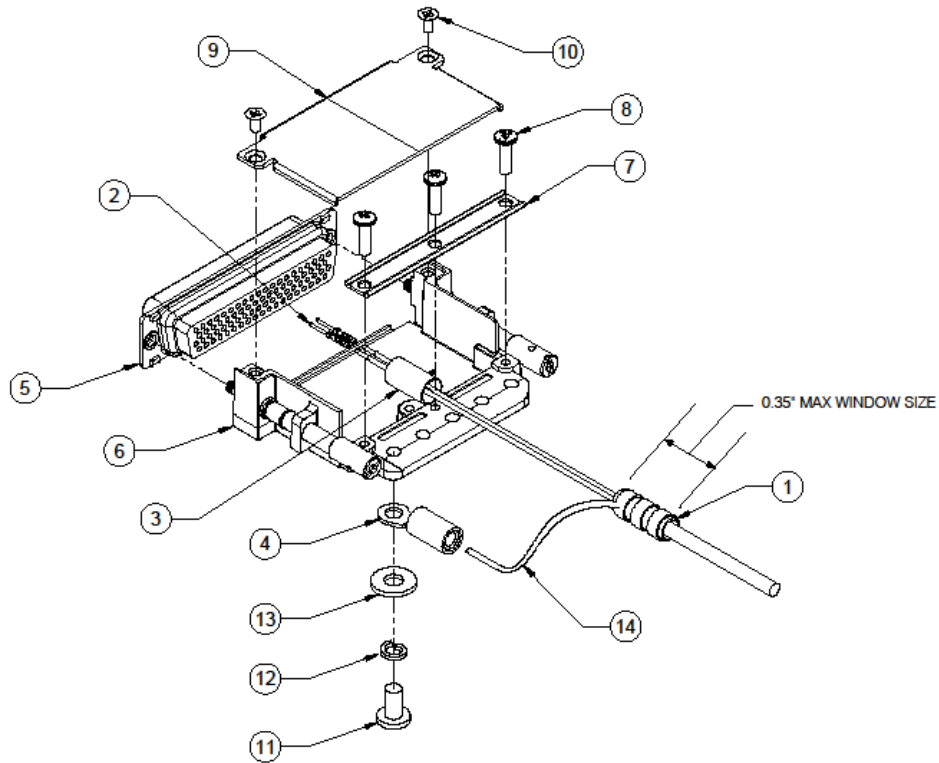
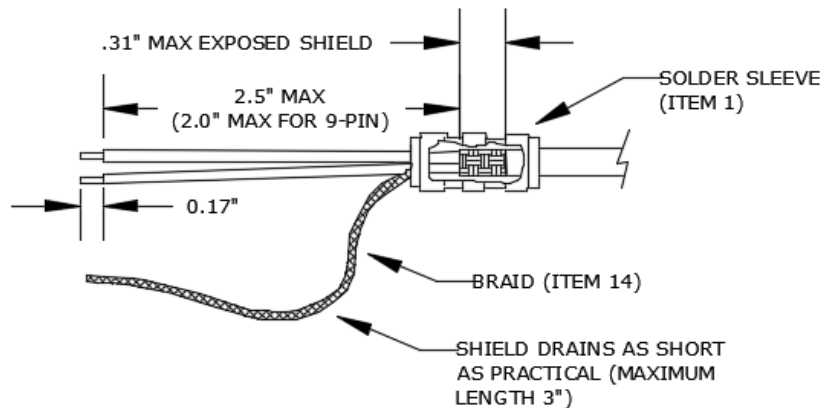

Figure 4-42 Wiring Harness Connector Assembly

NOTE: 78 pin D-sub connector shown, 9 pin and 25 pin D-sub connector similar.

This area intentionally blank

SHIELDED CABLE PREPARATION (PREFERRED METHOD)



SHIELDED CABLE PREPARATION (ALTERNATE METHOD)

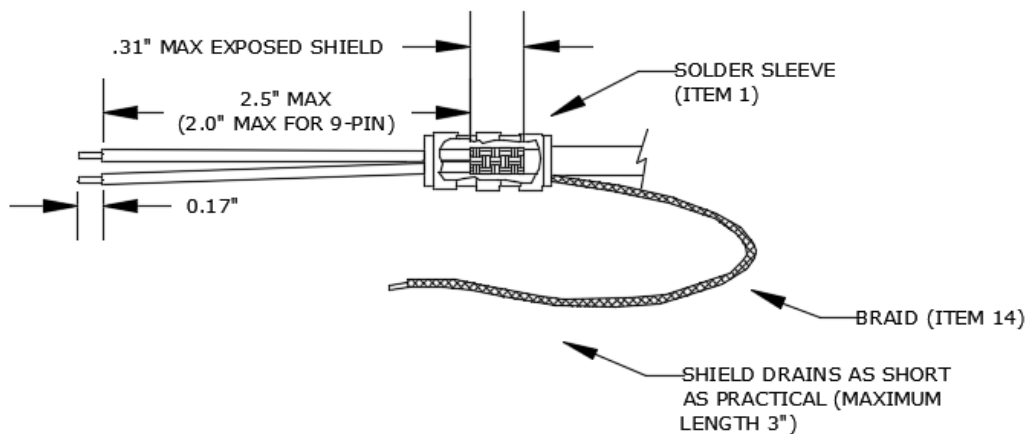

Figure 4-43 Shield Termination Methods

Prepare all of the shielded wires using one of the shield termination methods shown in Figure 4-43. Keep the shield drains as short as practical (3" max total length). See Table 4-4, Table 4-5, and Table 4-6 regarding numbers in parentheses in the following procedure.

1. Strip 2.5 inches (maximum) (2.0 inches maximum for 9-pin connectors) of the jacket to expose the shield braid.
2. Remove the exposed braid.
3. Carefully score the jacket 1/4 to 5/16 inches and remove the jacket to leave the braid exposed.
4. Slide a shield terminator (1) onto the exposed shield braid and insert shield braid drain (14) into shield terminator. Secure the shield terminator and braid drain to the shield using a heat gun approved for use with solder sleeves.



5. Strip the signal wires approximately 0.17 inches.
6. Crimp socket contacts (2) on to the signal wires.
7. Crimp ring terminals (4) on to the shield drain wires.
8. Repeat steps 1 through 7 as needed for the remaining shielded wires.
9. Insert the signal wire socket contacts into the appropriate locations in the D-sub connector (5).
10. Attach the shield drain ring terminals to the connector backshell shield block using the supplied screws and washers (11)(12)(13).
11. Wrap the wiring harness with silicone fusion tape (3) at the point where the strain relief clamp (7) and connector backshell (6) will contact the wiring harness.
12. Attach the strain relief clamp (7) to the connector backshell (6) using the supplied screws (8).



CAUTION

Placing the concave side of the strain relief clamp across the wiring harness will damage the wiring harness.



NOTE

Only two ring terminals should be attached to each screw on the connector backshell shield ground. It is preferred that only two wires be terminated in each ring terminal. This will necessitate the use of a ring terminal, #8, insulated, 14-16 AWG (MS25036-153). If only a single wire is left or if only a single wire is needed for this connector a ring terminal, #8, insulated, 18-22 AWG (MS25036-149) can be used. If more wires exist for the connector than two per ring terminal, it is permissible to terminate three wires per ring terminal.

13. Install the connector backshell cover (9) using the supplied screws (10).

This area intentionally blank



4.4 Weight and Balance

Weight and balance computations are required after the installation of the G5. Table 4-7 lists the weights associated with the G5 Electronic Flight Instrument. Refer to AC 43.13-1B, Chapter 10, for the weight and balance procedure covering the addition of equipment to the aircraft.

Table 4-7: LRU Weights

Item	Weight
G5 with Battery, connector and mounting ring	.98 lbs
GMU 11	.26 lbs
GAD 29	.63 lbs
GAD 29B	.65 lbs

4.5 Electrical Load Analysis

If the current draw of the G5 unit(s), GMU 11 or GAD 29/29B is less than the removed equipment, then the aircraft's electrical load capacity can be shown to be adequate by analysis. If it is determined the modification results in an increase in electrical load, then it must be verified the electrical generation and reserve battery capacity remain adequate to support electrical loads essential to safe flight and landing of the aircraft.

4.5.1 Aircraft with Existing Electrical Load Analysis

If there is an existing electrical load analysis for the aircraft, it must be updated to reflect the modification. It must show the electrical system has adequate capacity to supply power to the modified systems in all expected conditions. Refer to the aircraft manufacturer's documentation for guidance on revising and maintaining the electrical load analysis.

4.5.2 Aircraft without Existing Electrical Load Analysis

Prior to undertaking a complete electrical load analysis, the net change to the electrical load resulting from the G5 installation should be determined. See Table 4-8 for a sample calculation. The results of this analysis will be used to determine how to proceed further.

This area intentionally blank



4.5.2.1 Electrical Load is Reduced Following Modification

If calculations show the overall load on the electrical system is reduced as shown in the following example, no further analysis is required. This assumes the electrical system was within all limits prior to the G5, GMU 11 and GAD 29/29B installation. Record the new electrical load calculations.

Table 4-8: Sample Net Electrical Load Change Calculation

Items removed from aircraft:	Electrical Load (Amps) ¹
SUBTOTAL	

Items added to aircraft		
G5	14 V (typical) ⁽¹⁾	.200 A
	28 V (typical) ⁽¹⁾	.100 A
GMU11	14 V (typical) ⁽¹⁾	.100 A
	28 V (typical) ⁽¹⁾	.100 A
GAD 29/29B	14 V (typical) ⁽¹⁾	.200 A
	28 V (typical) ⁽¹⁾	.100 A
SUBTOTAL		

NET CHANGE IN BUS LOAD
 (NEW BUS LOAD – OLD BUS LOAD) _____

Notes:

- (1) Use 14 V or 28 V typical current draw depending on aircraft system when performing this calculation.

4.5.2.2 Electrical Load is Increased Following Modification

If it is determined the electrical load has increased an appreciable amount, a complete electrical load analysis must be performed to show the capacity of the electrical system is sufficient for the additional electrical load. For guidance on performing an electrical load analysis, refer to ASTM F 2490-05, Standard Guide for Aircraft Electrical Load and Power Source Capacity Analysis. Alternatively, the loads under various operating conditions may be measured, as described in Section 4.5.2.3.

4.5.2.3 Performing an Electrical Load Analysis by Measurement

This section describes how to perform an electrical load analysis for a single alternator-single battery electrical system. These procedures may be modified accordingly for aircraft with multiple batteries or alternators, and it must be shown the maximum electrical demand does not typically exceed 80% of the electrical system capacity.

In this section the following definitions are used:

normal operation: the primary electrical power generating system is operating normally.

emergency operation: the primary electrical power generating system is inoperative and a back-up electrical power generating system is being used. This typically requires load shedding of non-essential equipment to provide adequate electrical power to essential required equipment for safe flight and landing of the airplane.

Either an in-circuit or clamp-on ammeter can be used for current measurement. The instrument used must be calibrated and must be capable of reading current to the nearest 0.5 A, or better.

1. Record the continuous load rating for the alternator and battery.
2. Compile a list of electrical loads on the aircraft (generally, this is just a list of circuit breakers and circuit breaker switches).
3. Identify whether each load is *continuous* (e.g. GPS) or *intermittent* (e.g. stall warning horn, landing gear).
4. Using the worst-case flight condition, identify whether each load is used in a particular phase of flight for *normal* operation. If some loads are mutually exclusive and will not be turned on simultaneously (e.g. pitot heat and air conditioning), use only those loads for the worst-case condition.
5. Identify whether each load is used in a particular phase of flight for emergency operation. As a minimum, these systems generally include:
 - COM Radio #1
 - NAV Radio #1
 - Transponder and associated altitude source
 - Audio Panel
 - Stall Warning System (if applicable)
 - Pitot Heat

- Landing Light (switched on during landing only)
 - Instrument Panel Dimming
6. Insert/attach the ammeter in the line from the external power source to the master relay circuit as shown in Figure 4-44. This will eliminate errors due to the charging current drawn by the battery.



CAUTION

To avoid damage to equipment, ensure the ammeter is capable of handling the expected load.

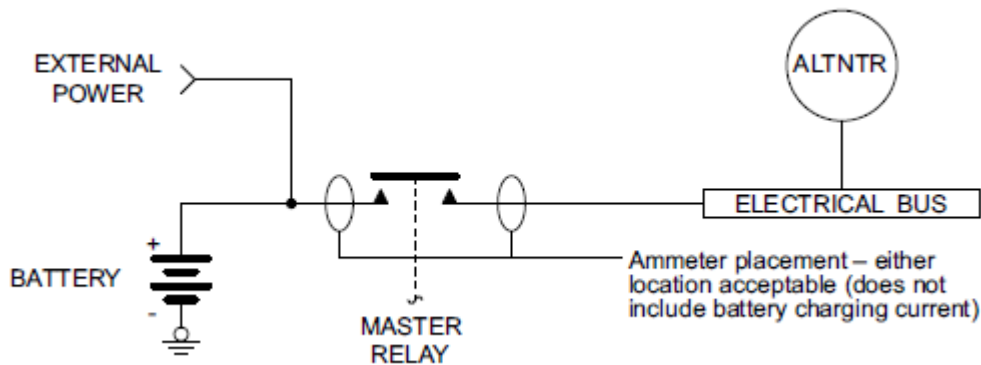

Figure 4-44 Ammeter Placement for Current Measurements

7. Ensure all circuit breakers are closed.
8. Apply external power to the aircraft. The voltage of the power source should be set to the nominal alternator voltage (usually 13.8 VDC or 27.5 VDC).
9. Turn on the battery master switch.



NOTE

Intermittent electrical loads are not measured. It is assumed if additional current is required beyond what the alternator can supply, this short-duration demand will be provided by the battery.

10. Set the lighting as described below. These settings will be used for every current measurement which follows:
 - Set instrument panel and flood lights to maximum brightness.
 - Set displays with a backlight to 50% brightness
11. Using the tabulation completed above, switch on all *continuous* electrical loads used for the taxiing phase and record the current measured by the ammeter (measurement (a) in Figure 4-45). The autopilot circuit breaker (if installed) should be closed, but the autopilot should not be engaged.



WARNING

Pitot heat should be switched on only long enough to take the current measurement and then switched off to avoid injury to personnel or damage to the Pitot tube.

12. Using the tabulation completed above, switch on all continuous electrical loads used for the **normal** takeoff/landing phase and record the current measured by the ammeter. Measurements must be taken with the landing lights ON and OFF (measurements (b1) and (b2) in Figure 4-45).
13. Engage the autopilot (if installed).
14. Using the tabulation completed above, switch on all continuous electrical loads which are used for the **normal** cruise phase and record the current measured by the ammeter (measurement (c) in Figure 4-45).
15. Using the tabulation completed above, switch on all continuous electrical loads used for the **emergency** cruise phase and record the current measured by the ammeter.
16. Using the tabulation completed above, switch on all continuous electrical loads used for the emergency landing phase and record the current measured by the ammeter.
17. Using the values measured and recorded, complete the ELA using the blank form in Figure 4-45 and Figure 4-46.
18. Verify the maximum electrical load does not exceed 80% of the electrical system capacity. See example in Figure 4-47 and Figure 4-48.



NOTE

Electrical loads in excess of 80% but not greater than 95% of electrical system capacity are permitted during the takeoff/landing phase of flight when landing light(s) are switched on.

This area intentionally blank



AIRPLANE ELECTRICAL LOAD TABULATION FORM

Date: _____ Tail Number: _____ Phase(s) of flight during which circuit/system is used

Circuit/System	Circuit Breaker Number	Operating Time	Normal Operation			Emergency Operation	
			Taxiing 10 min	TO/Land 10 min	Cruise 60 min	Cruise	Land 10 min

Figure 4-45 Blank Electrical Load Tabulation Form, Sheet 1 of 2



AIRPLANE ELECTRICAL LOAD TABULATION FORM (CONTINUED)

Date: _____ Tail Number: _____ Phase(s) of flight during which circuit/system is used

Circuit/System	Circuit Breaker Number	Operating Time	Normal Operation			Emergency Operation	
			Taxiing 10 min	TO/Land 10 min	Cruise 60 min	Cruise	Land 10 min
Total current used (amps):			{ _____ (a)	$\overline{\text{Ldg Lt ON}}$ (b1)	_____ (c)	_____ (d)	_____ (e)
+ Alternator rating (amps): _____				$\overline{\text{Ldg Lt OFF}}$ (b2)			
x 100% = Percent of alternator capacity used:			{ _____ % (< 80%)	_____ % $\overline{\text{Ldg Lt ON}}$ (< 95%)	_____ % (< 80%)	N/A	N/A
				_____ % $\overline{\text{Ldg Lt OFF}}$ (< 80%)			
Pass/Fail:			_____	_____	_____		

Notes:

Figure 4-46 Blank Electrical Load Tabulation Form, Sheet 2 of 2



ELECTRICAL LOAD TABULATION FORM

Date: 02/14/14 Tail Number: NXXXX

Phase(s) of flight during which circuit/system is used

Circuit/System	Circuit Breaker Number	Operating Time	Normal Operation			Emergency Operation	
			Taxiing 10 min	TD/Land 10 min	Cruise 60 min	Cruise	Land 10 min
ALTERNATOR FIELD		Continuous	<input checked="" type="checkbox"/>	<input checked="" type="checkbox"/>	<input checked="" type="checkbox"/>	<input type="checkbox"/>	<input type="checkbox"/>
ANNUNCIATOR PANEL		Continuous	<input checked="" type="checkbox"/>	<input checked="" type="checkbox"/>	<input checked="" type="checkbox"/>	<input checked="" type="checkbox"/>	<input checked="" type="checkbox"/>
VACUUM WARNING		Intermittent	<input type="checkbox"/>	<input type="checkbox"/>	<input type="checkbox"/>	<input type="checkbox"/>	<input type="checkbox"/>
GEAR WARNING		Intermittent	<input type="checkbox"/>	<input type="checkbox"/>	<input type="checkbox"/>	<input type="checkbox"/>	<input type="checkbox"/>
GEAR ACTUATOR		Intermittent	<input type="checkbox"/>	<input type="checkbox"/>	<input type="checkbox"/>	<input type="checkbox"/>	<input type="checkbox"/>
CLUSTER GAUGE		Continuous	<input checked="" type="checkbox"/>	<input checked="" type="checkbox"/>	<input checked="" type="checkbox"/>	<input checked="" type="checkbox"/>	<input checked="" type="checkbox"/>
IGNITION		Intermittent	<input type="checkbox"/>	<input type="checkbox"/>	<input type="checkbox"/>	<input type="checkbox"/>	<input type="checkbox"/>
PFD		Continuous	<input checked="" type="checkbox"/>	<input checked="" type="checkbox"/>	<input checked="" type="checkbox"/>	<input checked="" type="checkbox"/>	<input checked="" type="checkbox"/>
TURN COORDINATOR		Continuous	<input checked="" type="checkbox"/>	<input checked="" type="checkbox"/>	<input checked="" type="checkbox"/>	<input type="checkbox"/>	<input type="checkbox"/>
GEAR RELAY		Intermittent	<input type="checkbox"/>	<input type="checkbox"/>	<input type="checkbox"/>	<input type="checkbox"/>	<input type="checkbox"/>
ADC		Continuous	<input checked="" type="checkbox"/>	<input checked="" type="checkbox"/>	<input checked="" type="checkbox"/>	<input checked="" type="checkbox"/>	<input checked="" type="checkbox"/>
PANEL LIGHTS		Continuous	<input checked="" type="checkbox"/>	<input checked="" type="checkbox"/>	<input checked="" type="checkbox"/>	<input checked="" type="checkbox"/>	<input checked="" type="checkbox"/>
GLARESHIELD LIGHTS		Continuous	<input checked="" type="checkbox"/>	<input checked="" type="checkbox"/>	<input checked="" type="checkbox"/>	<input checked="" type="checkbox"/>	<input checked="" type="checkbox"/>
AHRS		Continuous	<input checked="" type="checkbox"/>	<input checked="" type="checkbox"/>	<input checked="" type="checkbox"/>	<input checked="" type="checkbox"/>	<input checked="" type="checkbox"/>
FLAP ACTUATOR		Intermittent	<input type="checkbox"/>	<input type="checkbox"/>	<input type="checkbox"/>	<input type="checkbox"/>	<input type="checkbox"/>
COM 1		Continuous	<input checked="" type="checkbox"/>	<input checked="" type="checkbox"/>	<input checked="" type="checkbox"/>	<input checked="" type="checkbox"/>	<input checked="" type="checkbox"/>
GPS/NAV 1		Continuous	<input checked="" type="checkbox"/>	<input checked="" type="checkbox"/>	<input checked="" type="checkbox"/>	<input checked="" type="checkbox"/>	<input checked="" type="checkbox"/>
COM 2		Continuous	<input checked="" type="checkbox"/>	<input checked="" type="checkbox"/>	<input checked="" type="checkbox"/>	<input type="checkbox"/>	<input type="checkbox"/>
GPS/NAV 2		Continuous	<input checked="" type="checkbox"/>	<input checked="" type="checkbox"/>	<input checked="" type="checkbox"/>	<input type="checkbox"/>	<input type="checkbox"/>
AUTOPILOT [1]		Continuous	<input checked="" type="checkbox"/>	<input checked="" type="checkbox"/>	<input checked="" type="checkbox"/>	<input type="checkbox"/>	<input type="checkbox"/>
AUDIO PANEL		Continuous	<input checked="" type="checkbox"/>	<input checked="" type="checkbox"/>	<input checked="" type="checkbox"/>	<input checked="" type="checkbox"/>	<input checked="" type="checkbox"/>
RADIO BLOWER		Continuous	<input checked="" type="checkbox"/>	<input checked="" type="checkbox"/>	<input checked="" type="checkbox"/>	<input type="checkbox"/>	<input type="checkbox"/>
ADF		Continuous	<input checked="" type="checkbox"/>	<input checked="" type="checkbox"/>	<input checked="" type="checkbox"/>	<input type="checkbox"/>	<input type="checkbox"/>
TRANSPONDER		Continuous	<input checked="" type="checkbox"/>	<input checked="" type="checkbox"/>	<input checked="" type="checkbox"/>	<input checked="" type="checkbox"/>	<input checked="" type="checkbox"/>
GDL 69		Continuous	<input checked="" type="checkbox"/>	<input checked="" type="checkbox"/>	<input checked="" type="checkbox"/>	<input type="checkbox"/>	<input type="checkbox"/>
GTS 8X5		Continuous	<input checked="" type="checkbox"/>	<input checked="" type="checkbox"/>	<input checked="" type="checkbox"/>	<input type="checkbox"/>	<input type="checkbox"/>
JPI ENGINE MONITOR		Continuous	<input checked="" type="checkbox"/>	<input checked="" type="checkbox"/>	<input checked="" type="checkbox"/>	<input checked="" type="checkbox"/>	<input checked="" type="checkbox"/>
BOSE HEADSETS		Continuous	<input checked="" type="checkbox"/>	<input checked="" type="checkbox"/>	<input checked="" type="checkbox"/>	<input checked="" type="checkbox"/>	<input checked="" type="checkbox"/>
ALTITUDE ENCODER		Continuous	<input checked="" type="checkbox"/>	<input checked="" type="checkbox"/>	<input checked="" type="checkbox"/>	<input checked="" type="checkbox"/>	<input checked="" type="checkbox"/>
STROBE LIGHT		Continuous	<input checked="" type="checkbox"/>	<input checked="" type="checkbox"/>	<input checked="" type="checkbox"/>	<input checked="" type="checkbox"/>	<input checked="" type="checkbox"/>
NAV LIGHTS		Continuous	<input checked="" type="checkbox"/>	<input checked="" type="checkbox"/>	<input checked="" type="checkbox"/>	<input checked="" type="checkbox"/>	<input checked="" type="checkbox"/>
RECOGNITION LIGHTS		Continuous	<input checked="" type="checkbox"/>	<input checked="" type="checkbox"/>	<input checked="" type="checkbox"/>	<input checked="" type="checkbox"/>	<input checked="" type="checkbox"/>
LANDING LIGHT		Continuous	<input checked="" type="checkbox"/>	<input checked="" type="checkbox"/>	<input type="checkbox"/>	<input type="checkbox"/>	<input checked="" type="checkbox"/>
PITOT HEAT		Continuous	<input checked="" type="checkbox"/>	<input checked="" type="checkbox"/>	<input checked="" type="checkbox"/>	<input checked="" type="checkbox"/>	<input checked="" type="checkbox"/>
BOOST PUMP		Continuous	<input type="checkbox"/>	<input checked="" type="checkbox"/>	<input checked="" type="checkbox"/>	<input checked="" type="checkbox"/>	<input checked="" type="checkbox"/>

Figure 4-47 Sample Completed Electrical Load Tabulation Form, Sheet 1 of 2



ELECTRICAL LOAD TABULATION FORM (CONTINUED)

Date: 02/14/14 Tail Number: NXXXX Phase(s) of flight during which circuit/system is used

Circuit/System	Circuit Breaker Number	Operating Time	Normal Operation			Emergency Operation	
			Taxiling 10 min	TO/Land 10 min	Cruise 60 min	Cruise	Land 10 min
_____	_____	_____	<input type="checkbox"/>	<input type="checkbox"/>	<input type="checkbox"/>	<input type="checkbox"/>	<input type="checkbox"/>
_____	_____	_____	<input type="checkbox"/>	<input type="checkbox"/>	<input type="checkbox"/>	<input type="checkbox"/>	<input type="checkbox"/>
_____	_____	_____	<input type="checkbox"/>	<input type="checkbox"/>	<input type="checkbox"/>	<input type="checkbox"/>	<input type="checkbox"/>
_____	_____	_____	<input type="checkbox"/>	<input type="checkbox"/>	<input type="checkbox"/>	<input type="checkbox"/>	<input type="checkbox"/>
_____	_____	_____	<input type="checkbox"/>	<input type="checkbox"/>	<input type="checkbox"/>	<input type="checkbox"/>	<input type="checkbox"/>
_____	_____	_____	<input type="checkbox"/>	<input type="checkbox"/>	<input type="checkbox"/>	<input type="checkbox"/>	<input type="checkbox"/>
_____	_____	_____	<input type="checkbox"/>	<input type="checkbox"/>	<input type="checkbox"/>	<input type="checkbox"/>	<input type="checkbox"/>
_____	_____	_____	<input type="checkbox"/>	<input type="checkbox"/>	<input type="checkbox"/>	<input type="checkbox"/>	<input type="checkbox"/>
_____	_____	_____	<input type="checkbox"/>	<input type="checkbox"/>	<input type="checkbox"/>	<input type="checkbox"/>	<input type="checkbox"/>
Total current used (amps):			47.5 (a)	60 Ldg Lt ON (b1) 44.7 Ldg Lt OFF (b2)	43.5 (c)	34.0 (d)	48.1 (e)
+ Alternator rating (amps):			70				
x 100% = Percent of alternator capacity used:			68 % (<u><</u> 80%)	86 % Ldg Lt ON (<u><</u> 95%) 64 % Ldg Lt OFF (<u><</u> 80%)	62 % (<u><</u> 80%)	N/A	N/A
Pass/Fail:			<u>PASS</u>	<u>PASS</u>	<u>PASS</u>		

Notes:

Figure 4-48 Sample Completed Electrical Load Tabulation Form, Sheet 2 of 2

4.6 Electrical Bonding

The GAD 29/29B is the only LRU installed by this STC that requires bonding. The following sections present data on acceptable methods of electrical bonding for the GAD 29/29B. Electrical bonding can be achieved with mounting hardware (rivets, bolts, nuts, washers, etc..) or via bond straps. A reliable electrical bond rely on mated surfaces to be clean of any primer/grease/dirt. When bolts are used to secure racks/brackets/etc.. and are relied upon for



electrical bond, in lieu of the mating surfaces of the racks/brackets/etc. then the area under the head of the bolt/screw or washer must be free of primer and a spot face should be prepared that is at least 0.125 inches wider than the head of the bolt or the washer (if used) under the head. If primer or film was removed to achieve this then any exposed area still visible after the bond is completed must be refinished with the original finish or other suitable film (eg primer) or coating, ref ARP1870. If the bolt is secured with washer and nut then a similar spot face as described above shall occur between the washer and the mounting structure. Rivets used to mechanically attach brackets/shelves/etc.. provide an inherent electrical bond through the rivets and require no additional bond preparation. Similarly riveted nut plates do not need any special bonding preparation and can be relied upon to provide electrical bond between the fastener and the nutplate. The top or bottom side of the Garmin racks or equipment flanges do not need any special bond preparations. Additional details on how to accomplish electrical bonding can also be found in SAE ARP1870 section 5.

When equipment is mounted to honeycomb shelves, the face sheets must be metal. The honeycomb material between the face sheets is not conductive and therefore care must be taken to make sure proper bonding of the equipment has taken place. The top and bottom faces sheets must be grounded to each other and one of the face sheets must be grounded to the airframe.

The instrument panel must be of metal construction so that remotely mounted units have a metal ground reference back to the other G5 interfacing equipment mounted on the instrument panel. For metal aircraft the latter is achieved inherently through the metallic aircraft structure. For composite aircraft a ground plane (or reference) may need to be created to achieve a comparable ground. This procedure is described in Section 4.6.2.

All LRU bonding measurements must be made with the connector(s) disconnected from the LRU.

4.6.1 Metal Aircraft

The GAD 29/29B and the support brackets require a resistance value of 2.5 milliohms or less between individual mating surfaces. For general steps on how to prepare aluminum surfaces for electrical bonding refer to Section 0.

If the instrument panel is attached by vibration mounts, verify that the mounts are grounded to the metallic airframe structure by means of a bonding jumper. Ensure that the installed bonding jumper meets the following specifications.

1. The braid is a 7/16" or wider tubular braid (part number QQB575R30T437, 24,120 circular mils) or a 3/4" or wider flat braid (part number QQB575F36T781, 20,800 circular mils).
2. The braid contains a terminal lug (mil-spec MS20659-130) at each end.
3. The strap length is as short as possible, not exceeding 6 inches.

Ensure that each terminal lug is secured to its respective mating surface with one #10 steel bolt and one flat washer (part number AN970-3). Lugs and washers should be center-aligned and flush on all outside edges. These components should be in full contact with the mating surface.

4.6.2 Nonmetallic Aircraft



NOTE

Carbon reinforced composite (with or without mesh) or fiberglass with mesh is considered to be conductive. Wood, Kevlar and fiberglass without mesh is considered to be non-conductive.

If the equipment is mounted in the metallic instrument panel then the bonding should be accomplished like that for metal aircraft (Section 4.6.1). For composite areas of the aircraft the GAD 29/29B must be electrically bonded to the metallic instrument panel either directly through the unit remote install/mounting rack or with heavy-duty dead soft aluminum tape such as 3M Heavy Duty Aluminum Foil Tape 438. The following guidance should be used for locating and bonding the LRU:

1. Identify a location for the LRU which is close to the instrument panel or the grounding structure for the instrument panel.
2. Identify a route between the LRU location and the instrument panel ground that will accommodate a strip of aluminum tape with a width of at least four inches and a length-to-width ratio of 7:1.
3. If the tape will come in contact with carbon composite material, the tape must be electrically isolated from the carbon composite material to prevent corrosion due to dissimilar materials. Secure a thin layer of fiberglass cloth to the carbon fiber with fiberglass resin as shown in Figure 4-49.

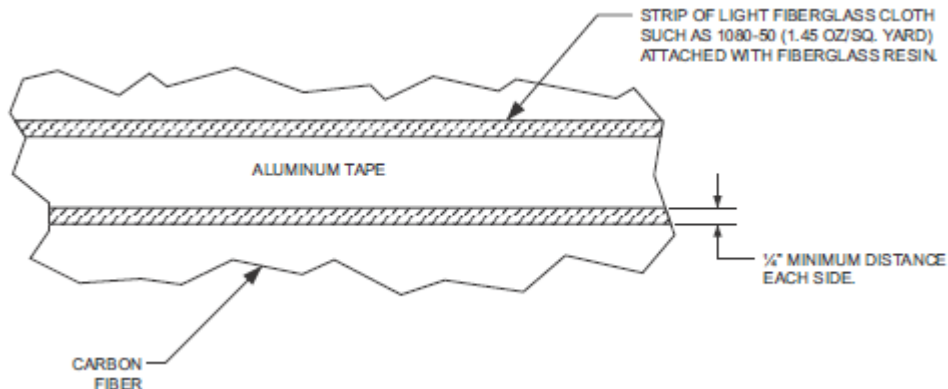

Figure 4-49 Fiberglass Insulation for Carbon Fiber Material

4. Identify a grounding location. The ground must be a bare metal surface on the instrument panel or grounding structure for the instrument panel. If it is impractical to reach a grounding location with aluminum tape then:
 - a. The tape shall meet a 5:1 length to width ratio.
 - b. The bond strap shall be one inch wide and no longer than five inches.
5. Prepare the aluminum surface at the ground location outlined in Section 0 or identify a ground stud to which the braid can be attached. Any new ground stud shall also be prepared for electrical bonding.
6. Route the tape between the LRU mount and the grounding location for the instrument panel. If needed to maintain the 7:1 length-to-width ratio, the tape can be overlapped in more than one strip.
7. If two pieces of tape need to be joined end-to-end, they can be joined as illustrated in Figure 4-50.

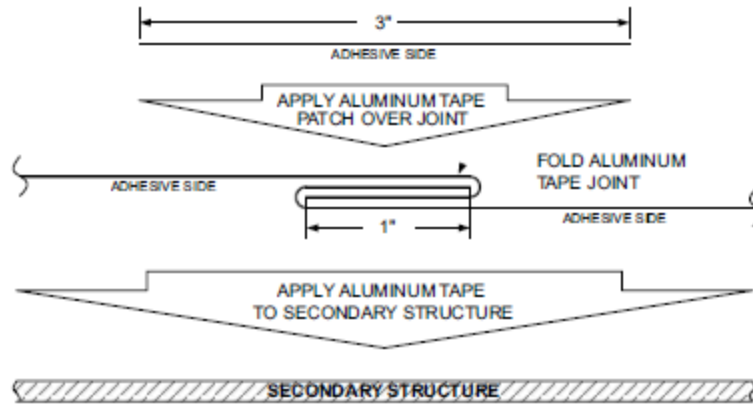

Figure 4-50 Aluminum Tape Joint

8. Fold the end of the tape over twice for added thickness at the prepared grounding location. Refer to Figure 4-51. Apply 3" wide tape over the seam as shown.
9. The tape shall not have any tears in the joint or along the length of the tape as tears will degrade the bonding performance.
10. Electrical bond preparation for all aluminum-to-aluminum interfaces per SAE ARP1870 section 5.1 and 5.5.
11. If a bonding strap will be used to reach the grounding location, secure the end of the tape to the secondary composite surface as shown in Figure 4-51. Note that the procedure for installing mounting bolts applies only to secondary aircraft structures, not to primary structure or structural load-carrying members. The tape shall meet 5:1 length to width ratio if a bonding strap is used. The bonding strap shall be one inch wide and no longer than five inches. Refer to Figure 4-51.
12. Terminate both ends of the bonding strap with MS20659-130 terminal lugs.
13. Install AN960C10 washer between the terminal lug and the mating metal surface and secure with a #10 steel bolt. Ensure that the lug and washer are centered and in full contact with the mating surface with no overhang when secured.
14. Secure the end of the tape in place using a 0.063" piece of aluminum using three bolts and nuts. Refer to Figure 4-51.
15. Secure the aluminum tape to the GAD 29/29B or mounting rack as shown in Figure 4-52.
16. Verify that the resistance between tape and the local grounding location does not exceed 2.5 mΩ.

This area intentionally blank

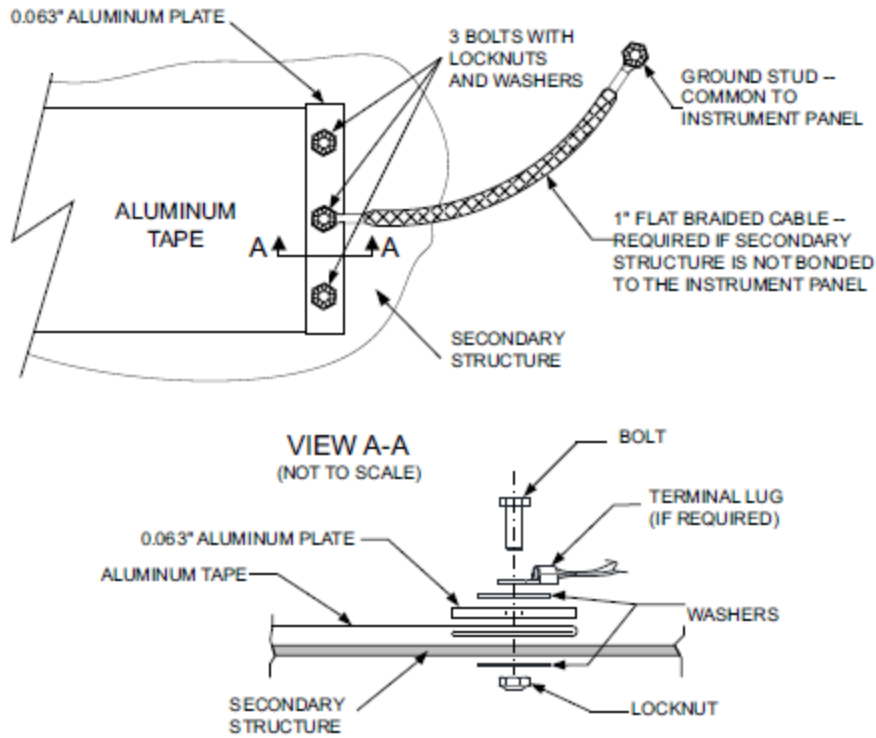

Figure 4-51 Aluminum Tape Ground Termination

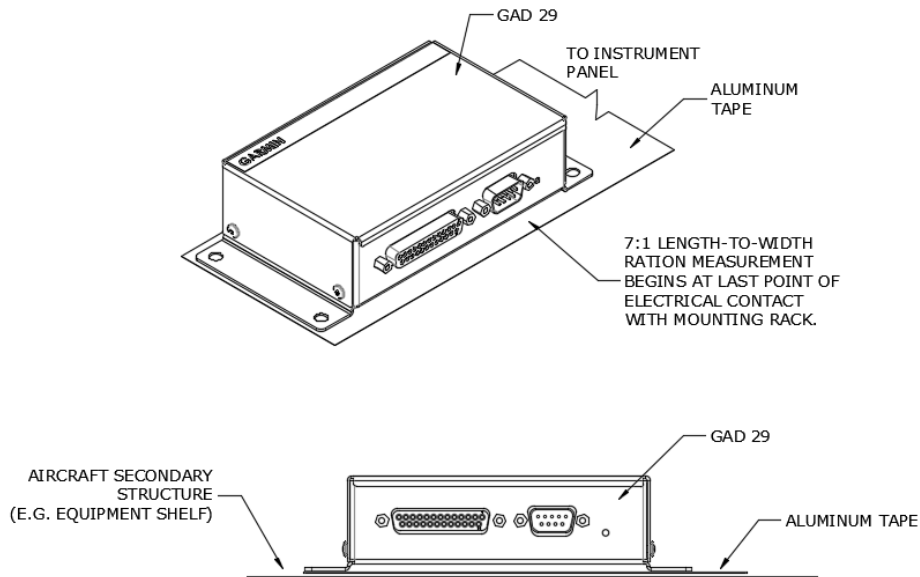

Figure 4-52 GAD 29/29B Aluminum Tape Installation



4.6.3 Aluminum Surface Preparation

In order to prepare the aluminum surface for proper bonding, the following general steps should be followed. For a detailed procedure, reference SAE ARP1870, Sections 5.1 and 5.5.

1. Clean grounding location with solvent.
2. Remove non-conductive films or coatings from the grounding location. When area is cleaned around fastener heads or washers the area cleaned should be 0.125 inches wider than the foot print of the washer or the bolt head.
3. Apply a chemical conversion coat such as Alodine 1200 to the bare metal.
4. Once the chemical conversion coat is dry, clean the area.
5. Install bonding aluminum tape or equipment at grounding location.
6. After the bond is complete, if any films or coatings were removed from the surface, reapply a suitable film or coating to the surrounding area.

This area intentionally blank



5 SYSTEM INTERCONNECTS

This section will provide the specific wiring interconnects for the various configuration possibilities for the G5 Attitude indicator and G5 DG/HSI installations. Each installation contains the specific G5 and or GPS/VHF Navigator configuration table. Power and Ground wiring is identical for each installation and is only shown in Figure 5-2.



NOTE:

The configuration tables are presented in order as the configuration pages on the G5 are presented. To make configuration of the G5 easier configure the ARINC 429 and or RS-232 options first. This allows for hidden configurations that require the ARINC 429 or RS-232 options to be selected as appropriate.

This area intentionally blank

5.1 G5 Interconnect Notes

1. UNLESS OTHERWISE SPECIFIED, REFER TO SAE AS50881, REV F ; WIRING AEROSPACE VEHICLE
2. UNLESS OTHERWISE SPECIFIED, ALL STRANDED WIRE IS 24 GAUGE MINIMUM AND SHALL MEET OR EXCEED M22759/35 SPEC OR EQUIVALENT. STRANDED WIRE 22 GAUGE AND LARGER SHALL MEET OR EXCEED M22759/34 SPEC OR EQUIVALENT. UNLESS OTHERWISE SPECIFIED, ALL SHIELDED WIRE SHALL MEET OR EXCEED M27500 SPEC OR EQUIVALENT USING THE M22759/34 WIRE AND INSULATION TYPE
3. THE FOLLOWING SYMBOLS ARE USED ON THIS DRAWING:

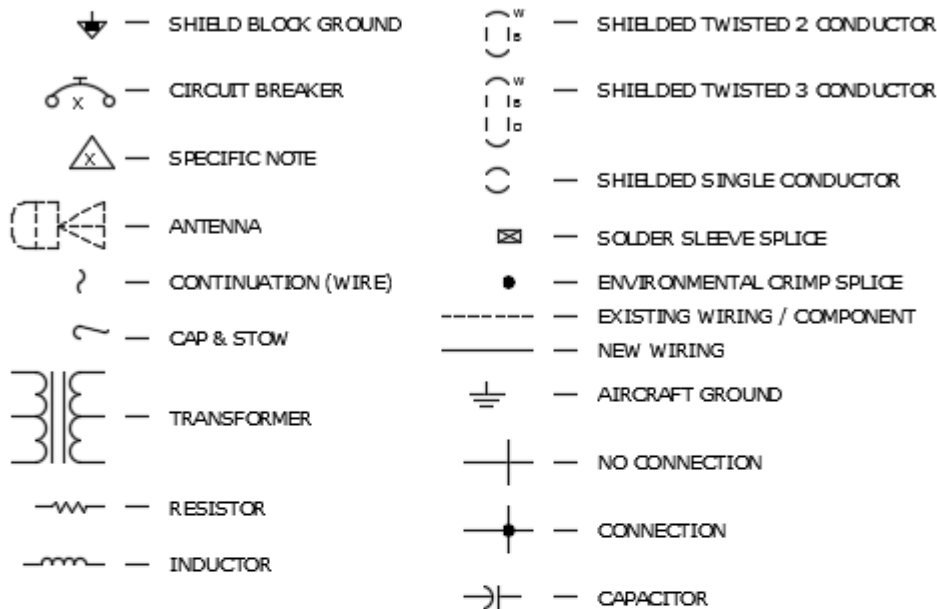

4. CRIMP SPLICE M81824/1-1 IS USED FOR SINGLE 26-20 GAUGE WIRE OR UP TO QTY 2 24 GAUGE (TWISTED TOGETHER, EACH SIDE OF SPLICE).
5. A SINGLE SHIELD BRAID IS TERMINATED USING AN 18-22 GAUGE TERMINAL
TWO SHIELD BRAIDS ARE TERMINATED USING A 14-16 GAUGE TERMINAL
THREE SHIELD BRAIDS ARE TERMINATED USING A 10-12 GAUGE TERMINAL

IN ALL CASES, CHOOSE THE TERMINAL THAT FITS THE MOUNTING STUD.

FOR GARMIN D-SUB BACKSHELLS, NO MORE THAN TWO TERMINALS PER SCREW ARE TO BE INSTALLED.
6. FOR COAXIAL CONNECTOR TERMINATION, REFER TO SPECIFIC CONNECTOR MANUFACTURER INFORMATION.
7. FOR G5, GMU11, AND GAD29/29B CONNECTOR ASSEMBLY AND SHIELD TERMINATION INSTRUCTIONS REFERENCE FIGURES 4-17 AND 4-18.
8. FOR LRUS INTERFACING TO G5 SYSTEM WIRING REFERENCE THE MANUFACTURERS INSTALLATION MANUAL FOR CONNECTOR ASSEMBLY AND SHIELD TERMINATION INSTRUCTIONS.
9. LOWER-CASE LETTERS ARE DEPICTED AS UPPER-CASE LETTERS FOLLOWED BY AN ASTERISK.
10. FOR SPLICES NEAR CONNECTORS, MAXIMUM LENGTH FROM SPLICE TO CONNECTOR IS THREE INCHES.
11. CONFIGURATION/STRAPPING JUMPERS MAXIMUM LENGTH IS FOUR INCHES.

Figure 5-1 G5 Interconnect Notes



CAUTION

Check wiring connections for errors before connecting the wiring harness to the LRUs. Incorrect wiring could cause component damage.

5.2 Power and Ground

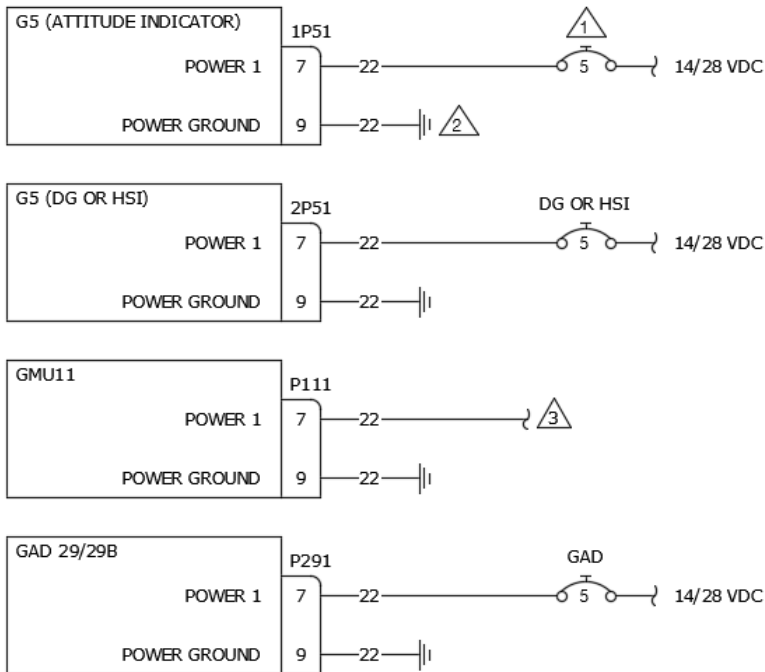

CIRCUIT BREAKER MUST BE LABELED DIRECTLY ADJACENT TO THE CIRCUIT BREAKER AS "ATT" WHEN THE G5 IS INSTALLED AS THE PRIMARY ATTITUDE INDICATOR REGARDLESS OF THE ORIGINAL INSTRUMENT IT IS REPLACING. THE CIRCUIT BREAKER MUST BE READILY ACCESSIBLE TO THE PILOT. ALTERNATE SPELLINGS OR ABBREVIATIONS OF ATTITUDE INDICATOR ARE ACCEPTABLE.



THE G5 POWER GROUND MUST BE INDEPENDENT FROM THE POWER GROUND USED BY THE RATE OF TURN INDICATOR IF THE RATE OF TURN IS RELIANT ON ELECTRICAL POWER.



WHEN A G5 DG/HSI IS INSTALLED THE GMU11 MUST BE POWERED FROM THE DG/HSI CIRCUIT BREAKER. WHEN A G5 DG/HSI IS NOT INSTALLED AND A GMU11 IS INSTALLED WITH A G5 ATTITUDE THE GMU11 MUST BE POWERED FROM THE ATTITUDE CIRCUIT BREAKER. THE GMU11 AND G5 POWER WIRES MUST BE IN SEPARATE TERMINALS AT THE CIRCUIT BREAKER.

Figure 5-2 Power and Ground

This area intentionally blank

5.3 G5 (Attitude Indicator) with External GPS Antenna



Figure 5-3 G5 (Attitude Indicator) with External GPS Antenna

5.3.1 Attitude Indicator Configuration

Config Page	Config Option	Configuration Setting
Device Information	Installation Type	Standalone Instrument
	Diagnostics/Data Log	Enabled
Attitude Configuration	Indicator Type	Normal
	Pitch Display	Normal
	Roll Display	For Fixed Type Pointers G5 Config = Ground or For Movable Type Pointers G5 Config = Sky
	User Pitch Offset	Disabled
	Automatic Declutter	Enabled
Air Data	Air Data Sensors	Enabled
	Vertical Speed Indicator	(1)(2)
Airspeed Note: Configure Units prior to setting airspeeds.	VNE	(1)(2)(3)
	VNO	(1)(2)(3)
	VSO	(1)(2)(3)
	VS1	(1)(2)(3)
	VFE	(1)(2)(3)
	VA	(1)(2)(3)
	VX	(1)(2)(3)
	VY	(1)(2)(3)
	VG	(1)(2)(3)
	VR	(1)(2)(3)
	VMC	(1)(2)(3)
VYSE	(1)(2)(3)	
Magnetometer	Magnetometer	Disabled
Flight Controls	Autopilot Servos	None
Backlight	Current Mode	Automatic
	Default Mode	Automatic
	Minimum Photocell Input	Default
	Minimum Display Brightness	Default
	Maximum Photocell Input	Default
	Maximum Display Brightness	Default
	Filter Time Constant	Default
Display	HSI Page	Disabled
	Power Up Page	PFD
Battery	Show Battery Status	When Using Battery
	Automatic Power Off	On Ground Only
GPS	Internal GPS Receiver	Enabled
	GPS Data Field	Show
Units	Altitude	(1)(2)



Config Page	Config Option	Configuration Setting
	Airspeed	(1)(2)(3)
	Ground Speed	(1)(2)
	Ground Track	Magnetic
	Vertical Speed	(1)(2)(3)
	Pressure	(1)(2)
	Data Field Units Display	Alternate
RS-232	Input Format	None
	Output Format	None
ARINC 429	Output 1	None
	Output 2	None
	Input 1	None
	Input 2	None
	Input 3	None
	Input 4	None
Exit Configuration Mode		

Note 1: Set configuration values and units to match the values indicated in the appropriate AFM and document settings in the space provided.

Note 2: If the aircraft has no AFM set the values as determined by the existing placards, instrument bugs or instrument markings.

Note 3: Existing placards related to airspeed limitations must be retained.

This area intentionally blank

5.4 G5 (Attitude Indicator) with GPS Position Input

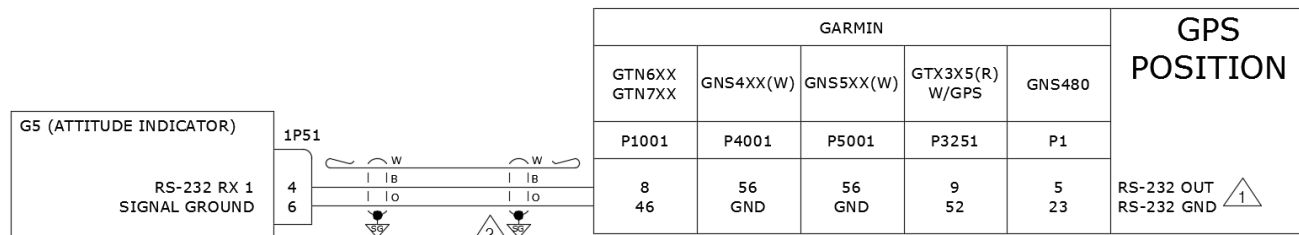

 CONNECT TO AN APPROPRIATELY CONFIGURED, AVAILABLE RS-232 PORT.

 IT IS ACCEPTABLE TO SPLICE WIRES TO EXISTING WIRING. TERMINATE SHIELD GROUNDS TO CONNECTOR BACKSHELL. SHIELD LEADS MUST BE MAX 3.0 INCHES. REFER TO UNIT INSTALLATION MANUALS FOR MORE INFORMATION.

Figure 5-4 G5 (Attitude Indicator) with GPS Position Input

5.4.1 Attitude Indicator

Config Page	Config Option	Configuration Setting
Device Information	Installation Type	Standalone Instrument
	Diagnostics/Data Log	Enabled
Attitude Configuration	Indicator Type	Normal
	Pitch Display	Normal
	Roll Display	For Fixed Type Pointers G5 Config = Ground or For Movable Type Pointers G5 Config = Sky
	User Pitch Offset	Disabled
	Automatic Declutter	Enabled
Air Data	Air Data Sensors	Enabled
	Vertical Speed Indicator	(1)(2)
Airspeed Note: Configure Units prior to setting airspeeds.	VNE	(1)(2)(3)
	VNO	(1)(2)(3)
	VSO	(1)(2)(3)
	VS1	(1)(2)(3)
	VFE	(1)(2)(3)
	VA	(1)(2)(3)
	VX	(1)(2)(3)
	VY	(1)(2)(3)
	VG	(1)(2)(3)
	VR	(1)(2)(3)
	VMC	(1)(2)(3)
VYSE	(1)(2)(3)	
Magnetometer	Magnetometer	Disabled
Flight Controls	Autopilot Servos	None
Backlight	Current Mode	Automatic
	Default Mode	Automatic
	Minimum Photocell Input	Default
	Minimum Display Brightness	Default
	Maximum Photocell Input	Default
	Maximum Display Brightness	Default



Config Page	Config Option	Configuration Setting
	Filter Time Constant	Default
Display	HSI Page	Disabled
	Power Up Page	PFD
Battery	Show Battery Status	When Using Battery
	Automatic Power Off	On Ground Only
GPS	Internal GPS Receiver	Disabled
	Show Data Fields Note: This configuration item is only present when RS-232 Input Format is configured for MapMx	Show
Navigation Note: This configuration Page is only present when RS-232 Input Format is configured for MapMx	Navigation Data	Disabled
Units	Altitude	(1)(2)
	Distance	(1)(2)
	Airspeed	(1)(2)(3)
	Ground Speed	(1)(2)
	Ground Track	Magnetic
	Vertical Speed	(1)(2)
	Pressure	(1)(2)
	Data Field Units Display	Alternate
RS-232	Input Format	MapMx (WAAS Units) AVIATION (Non WAAS Units)
	Output Format	None
ARINC 429	Output 1	None
	Output 2	None
	Input 1	None
	Input 2	None
	Input 3	None
	Input 4	None
Exit Configuration Mode		

5.4.2 GTN 6XX/7XX Configuration

Config Page	Config Option	Configuration Setting
RS-232	RS-232 (x) (x represents any available RS-232 Port)	Output = MapMX Format 2

5.4.3 GNS 4XX(W) / 5XX(W) Configuration

Config Page	Config Option	Configuration Setting
MAIN RS232 CONFIG Page	RS-232 (x) (x represents any available RS-232 Channel)	Input = OFF Output = MapMX (WAAS) AVIATION (Non WAAS)



5.4.4 GNS 480 Configuration

Config Page	Config Option	Configuration Setting
GND Maint Serial Setup	CH (x) (x represents any available Serial Channel)	Output = MapMX

5.4.5 GTX 3x5 Configuration

Config Page	Config Option	Configuration Setting
Interface Group	RS-232 (x) (x represents any available RS-232 Channel)	Output = MapMX

Note 1: Set configuration values and units to match the values indicated in the appropriate AFM and document settings in the space provided.

Note 2: If the aircraft has no AFM set the values as determined by the existing placards, instrument bugs or instrument markings.

Note 3: Existing placards related to airspeed limitations must be retained.

This area intentionally blank

5.5 G5 (Attitude Indicator) and GMU 11 with GPS Position Input

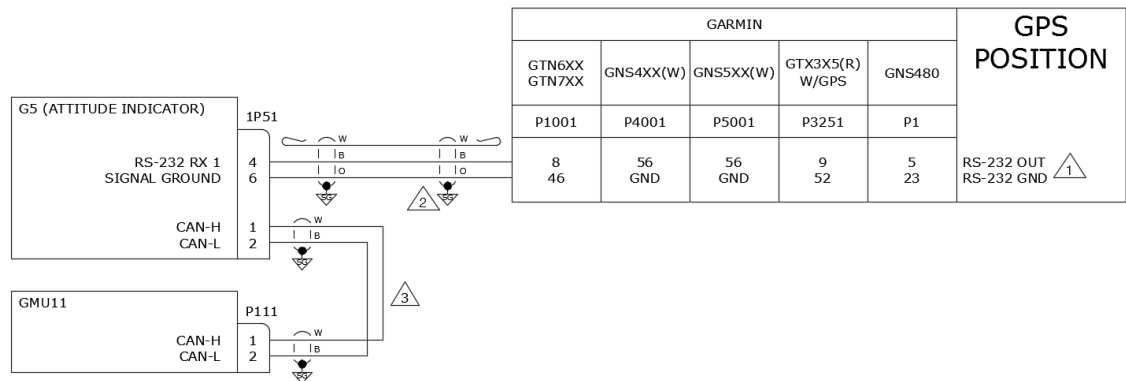



-  CONNECT TO AN APPROPRIATELY CONFIGURED, AVAILABLE RS-232 PORT.
-  IT IS ACCEPTABLE TO SPLICE WIRES TO EXISTING WIRING. TERMINATE SHIELD GROUNDS TO CONNECTOR BACKSHELL. SHIELD LEADS MUST BE MAX 3.0 INCHES. REFER TO UNIT INSTALLATION MANUALS FOR MORE INFORMATION.
-  REFER TO THE CAN BUS TERMINATION SECTION FOR FURTHER CAN BUS INFORMATION.

Figure 5-5 G5 (Attitude Indicator) and GMU 11 with GPS Position Input

5.5.1 Attitude Indicator Configuration

Config Page	Config Option	Configuration Setting
Device Information	Installation Type	Standalone Instrument
	Diagnostics/Data Log	Enabled
Attitude Configuration	Indicator Type	Normal
	Pitch Display	Normal
	Roll Display	For Fixed Type Pointers G5 Config = Ground or For Movable Type Pointers G5 Config = Sky
	User Pitch Offset	Disabled
	Automatic Declutter	Enabled
Air Data	Air Data Sensors	Enabled
	Vertical Speed Indicator	(1)(2)
Airspeed Note: Configure Units prior to setting airspeeds.	VNE	(1)(2)(3)
	VNO	(1)(2)(3)
	VSO	(1)(2)(3)
	VS1	(1)(2)(3)
	VFE	(1)(2)(3)
	VA	(1)(2)(3)
	VX	(1)(2)(3)
	VY	(1)(2)(3)
	VG	(1)(2)(3)
	VR	(1)(2)(3)
	VMC	(1)(2)(3)
VYSE	(1)(2)(3)	
Magnetometer	Magnetometer	Enabled
	Orientation	Connector Aft Or Connector Forward Or Connector Port Or Connector Starboard



Config Page	Config Option	Configuration Setting
Flight Controls	Autopilot Servos	None or See Section 5.12 if a Third Party Autopilot is interfaced
Backlight	Current Mode	Automatic
	Default Mode	Automatic
	Minimum Photocell Input	Default
	Minimum Display Brightness	Default
	Maximum Photocell Input	Default
	Maximum Display Brightness	Default
	Filter Time Constant	Default
Display	HSI Page	Disabled
	Power Up Page	PFD
Battery	Show Battery Status	When Using Battery
	Automatic Power Off	On Ground Only
GPS	Internal GPS Receiver	Disabled
	Show Data Fields Note: This configuration item is only present when RS-232 Input Format is configured for MapMx	Show
Navigation Note: Only used if a third party autopilot is configured. If a third party autopilot interface is configured ON, this configuration page is set to ENABLED by default.	Navigation Data	Enabled
Units	Altitude	(1)(2)
	Distance	(1)(2)
	Airspeed	(1)(2)(3)
	Ground Speed	(1)(2)
	Ground Track	Magnetic
	Vertical Speed	(1)(2)
	Pressure	(1)(2)
	Data Field Units Display	Alternate
RS-232	Input Format	MapMx (WAAS Units) AVIATION (Non WAAS Units)
	Output Format	None
ARINC 429	Output 1	None
	Output 2	None
	Input 1	None
	Input 2	None
	Input 3	None
	Input 4	None
Exit Configuration Mode		

5.5.2 GTN 6XX/7XX Configuration

Config Page	Config Option	Configuration Setting
RS-232	RS-232 (x) (x represents any available RS-232 Port)	Output = MapMX Format 2



5.5.3 GNS 4XX(W) / 5XX(W) Configuration

Config Page	Config Option	Configuration Setting
MAIN RS232 CONFIG Page	RS-232 (x) (x represents any available RS-232 Channel)	Input = OFF Output = MapMX (WAAS) AVIATION (Non WAAS)

5.5.1 GNS 480 Configuration

Config Page	Config Option	Configuration Setting
GND Maint Serial Setup	CH (x) (x represents any available Serial Channel)	Output = MapMX

5.5.2 GTX 3x5 Configuration

Config Page	Config Option	Configuration Setting
Interface Group	RS-232 (x) (x represents any available RS-232 Channel)	Output = MapMX

Note 1: Set configuration values and units to match the values indicated in the appropriate AFM and document settings in the space provided.

Note 2: If the aircraft has no AFM set the values as determined by the existing placards, instrument bugs or instrument markings.

Note 3: Existing placards related to airspeed limitations must be retained.

This area intentionally blank

5.6 G5 (Attitude Indicator or DG), GMU 11 and GPS Antenna

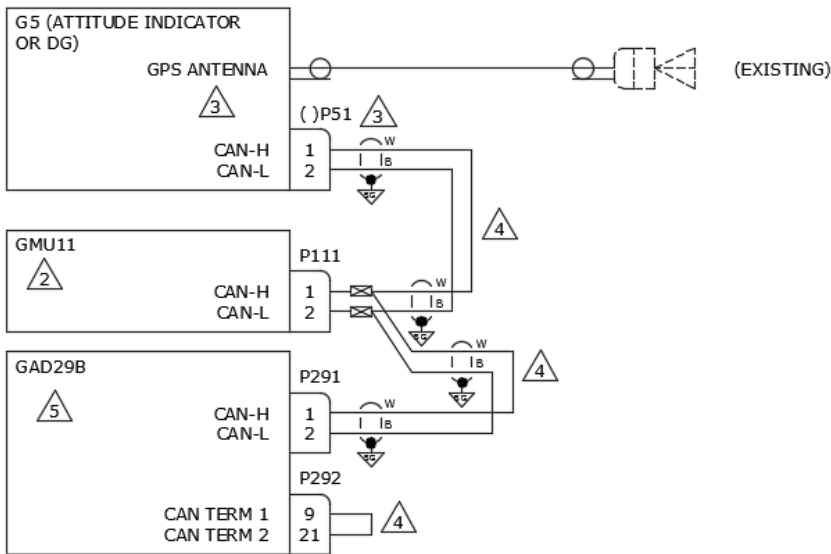

- 1 EXTERNAL GPS ANTENNA IS ONLY REQUIRED FOR A G5 IN THE ATTITUDE INDICATOR OR TURN COORDINATOR POSITION. EXTERNAL GPS ANTENNA IS OPTIONAL FOR A G5 IN THE DG POSITION.
- 2 GMU11 ONLY REQUIRED FOR A G5 INSTALLED IN THE DG POSITION. GMU11 IS OPTIONAL FOR A G5 INSTALLED IN THE ATTITUDE INDICATOR OR TURN COORDINATOR POSITION.
- 3 LABEL CONNECTOR "1P51" FOR A G5 IN THE ATTITUDE INDICATOR OR TURN COORDINATOR POSITION. LABEL CONNECTOR "2P51" FOR A G5 IN THE DG POSITION.
- 4 REFER TO THE CAN BUS TERMINATION SECTION FOR FURTHER CAN BUS INFORMATION.
- 5 GAD29B IS ONLY INSTALLED WHEN A G5 INSTALLED AS A DG IS INTERFACING WITH A THIRD-PARTY AUTOPILOT FOR HEADING DATUM OUT ONLY. SEE THE GAD29B INTERFACE TO THIRD-PARTY AUTOPILOT INTERCONNECT DIAGRAMS FOR FURTHER INFORMATION.

Figure 5-6 G5 (Attitude Indicator or DG), GMU 11 and GPS Antenna

5.6.1 Attitude Indicator or DG Configuration

Config Page	Config Option	Configuration Setting
Device Information	Installation Type	Standalone Instrument
	Diagnostics/Data Log	Enabled
Attitude Configuration	Indicator Type	Normal
	Pitch Display	Normal
	Roll Display	For Fixed Type Pointers G5 Config = Ground or For Movable Type Pointers G5 Config = Sky
	User Pitch Offset	Disabled
	Automatic Declutter	Enabled
Air Data	Air Data Sensors	Enabled
	Vertical Speed Indicator	(1)(2)
Airspeed	VNE	(1)(2)(3)
	VNO	(1)(2)(3)
	VSO	(1)(2)(3)
	VS1	(1)(2)(3)
	VFE	(1)(2)(3)
	VA	(1)(2)(3)
	VX	(1)(2)(3)
Note: Configure Units prior to setting airspeeds.		



Config Page	Config Option	Configuration Setting
	VY	(1)(2)(3)
	VG	(1)(2)(3)
	VR	(1)(2)(3)
	VMC	(1)(2)(3)
	VYSE	(1)(2)(3)
Magnetometer	Magnetometer Orientation	Enabled Connector Aft Or Connector Forward Or Connector Port Or Connector Starboard
Flight Controls	Autopilot Servos	None or See Section 5.12 if a Third Party Autopilot is interfaced
Backlight	Current Mode	Automatic
	Default Mode	Automatic
	Minimum Photocell Input	Default
	Minimum Display Brightness	Default
	Maximum Photocell Input	Default
	Maximum Display Brightness	Default
	Filter Time Constant	Default
Display (When used as an Attitude or Turn Coord)	HSI Page	Disabled
	Power Up Page	PFD
Display (When used as a DG)	HSI Page	Enabled
	Power Up Page	HSI
Battery	Show Battery Status	When Using Battery
	Automatic Power Off	On Ground Only
GPS	Internal GPS Receiver	Enabled
	GPS Data Fields	Show
Navigation Note: Only used if a third party autopilot is configured. If a third party autopilot interface is configured ON, this configuration page is set to ENABLED by default.	Navigation Data	Enabled
Units	Altitude	(1)(2)
	Airspeed	(1)(2)(3)
	Ground Speed	(1)(2)
	Ground Track	Magnetic
	Vertical Speed	(1)(2)
	Pressure	(1)(2)
	Data Field Units Display	Alternate
RS-232	Input Format	None
	Output Format	None
ARINC 429	Output 1	None
	Output 2	None
	Input 1	None
	Input 2	None
	Input 3	None
	Input 4	None
Exit Configuration Mode		



Note 1: Set configuration values and units to match the values indicated in the appropriate AFM and document settings in the space provided.

Note 2: If the aircraft has no AFM set the values as determined by the existing placards, instrument bugs or instrument markings.

Note 3: Existing placards related to airspeed limitations must be retained.

This area intentionally blank

5.7 G5 (HSI) with VHF Navigator

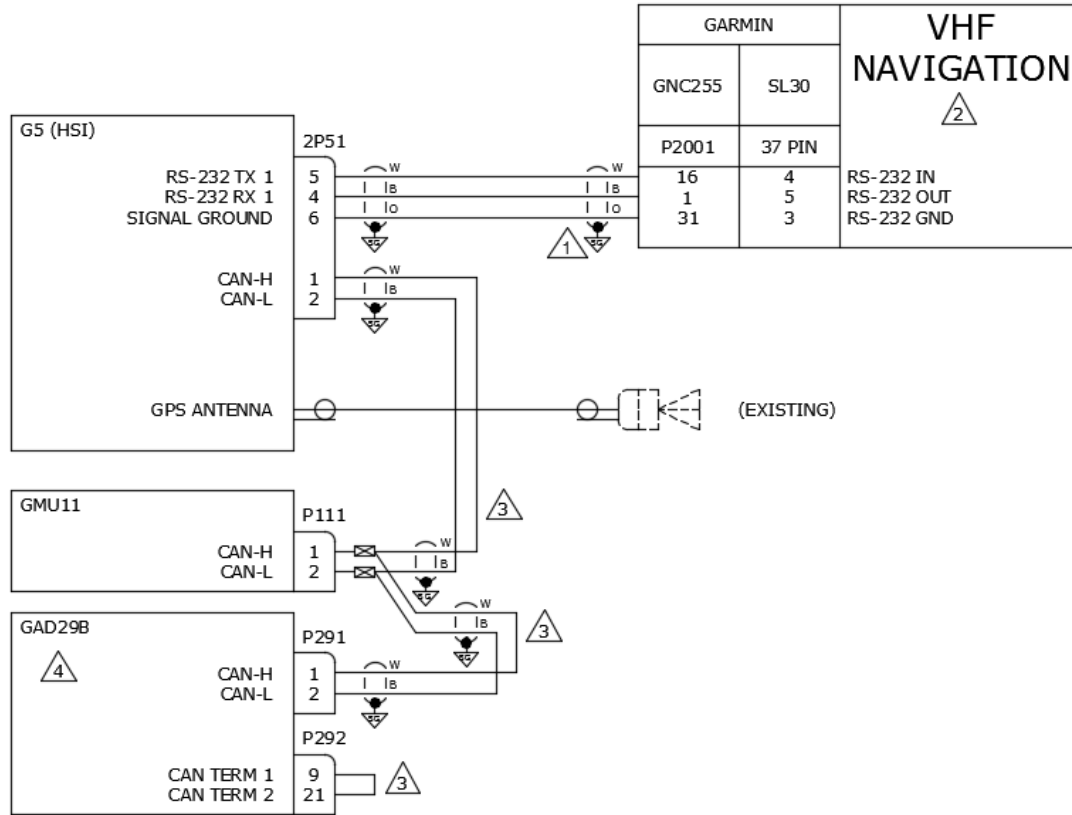

- 1 TERMINATE SHIELD GROUNDS TO CONNECTOR BACKSHELL. SHIELD LEADS MUST BE MAX 3.0 INCHES. REFER TO UNIT INSTALLATION MANUALS FOR MORE INFORMATION.
- 2 THIS STC DOES NOT APPROVE A CDI INTERFACED WITH THE SAME NAVIGATOR AS THE G5. REMOVE ANY EXISTING CDI INTERFACED WITH THIS NAVIGATOR.
- 3 REFER TO CAN BUS TERMINATION SECTION FOR FURTHER CAN BUS INFORMATION.
- 4 GAD29B ONLY INSTALLED WHEN INTERFACING WITH THIRD-PARTY AUTOPILOTS. SEE GAD29B INTERFACE TO THIRD-PARTY AUTOPILOT INTERCONNECT DIAGRAMS FOR FURTHER INFORMATION.

Figure 5-7 G5 (HSI) with VHF Navigator

5.7.1 G5 HSI Configuration (VHF Navigator)

Config Page	Config Option	Configuration Setting
Device Information	Installation Type	Standalone Instrument
	Diagnostics/Data Log	Enabled
Attitude Configuration	Instrument Type	Normal
	Pitch Display	Normal
	Roll Display	For Fixed Type Pointers G5 Config = Ground or For Movable Type Pointers G5 Config = Sky
	User Pitch Offset	Disabled
	Automatic Declutter	Disabled
Air Data	Air Data Sensors	Enabled
	Vertical Speed Indicator	(1)(2)
Airspeed	VNE	(1)(2)(3)



Config Page	Config Option	Configuration Setting
Note: Configure Units prior to setting airspeeds.	VNO	(1)(2)(3)
	VSO	(1)(2)(3)
	VS1	(1)(2)(3)
	VFE	(1)(2)(3)
	VA	(1)(2)(3)
	VX	(1)(2)(3)
	VY	(1)(2)(3)
	VG	(1)(2)(3)
	VR	(1)(2)(3)
	VMC	(1)(2)(3)
VYSE	(1)(2)(3)	
Magnetometer	Magnetometer	Enabled
	Orientation	Connector Aft Or Connector Forward Or Connector Port Or Connector Starboard
Flight Controls	Autopilot Servos	None or See Section 5.12 if a Third Party Autopilot is interfaced
Backlight	Current Mode	Automatic
	Default Mode	Automatic
	Minimum Photocell Input	Default
	Minimum Display Brightness	Default
	Maximum Photocell Input	Default
	Maximum Display Brightness	Default
	Filter Time Constant	Default
Display	HSI Page	Enabled
	Power Up Page	HSI
Battery	Show Battery Status	When Using Battery
	Automatic Power Off	On Ground Only
GPS	Internal GPS Receiver	Enabled
	GPS Data Fields	Show
Navigation Note: This configuration Page is only present when RS-232 Input Format is configured for Garmin VHF NAV Radio Note: If a third party autopilot interface is configured ON, this configuration page is set to ENABLED by default.	Navigation Data	Enabled
Units	Altitude	(1)(2)
	Airspeed	(1)(2)(3)
	Vertical Speed	(1)(2)
	Pressure	(1)(2)
	Data Field Units Display	Alternate
RS-232	Input Format	Garmin VHF NAV Radio
	Output Format	Garmin VHF NAV Radio
ARINC 429	Output 1	None
	Output 2	None
	Input 1	None



Config Page	Config Option	Configuration Setting
	Input 2	None
	Input 3	None
	Input 4	None
Exit Configuration Mode		

5.7.2 GNC 255 Configuration

Config Page	Config Option	Configuration Setting
Sys Configuration	RS 232 Serial Port	IO Mode = NMEA
Attitude Configuration	CDI Indicator	TYPE = Serial

5.7.3 SL30 Configuration

Config Page	Config Option	Configuration Setting
Sys Configuration	RS 232 Serial Port	No Setting
Attitude Configuration	Indicator Type	TYPE = Serial

Note 1: Set configuration values and units to match the values indicated in the appropriate AFM and document settings in the space provided.

Note 2: If the aircraft has no AFM set the values as determined by the existing placards, instrument bugs or instrument markings.

Note 3: Existing placards related to airspeed limitations must be retained.

This area intentionally blank

5.8 G5 (HSI) with GPS/VHF Navigator

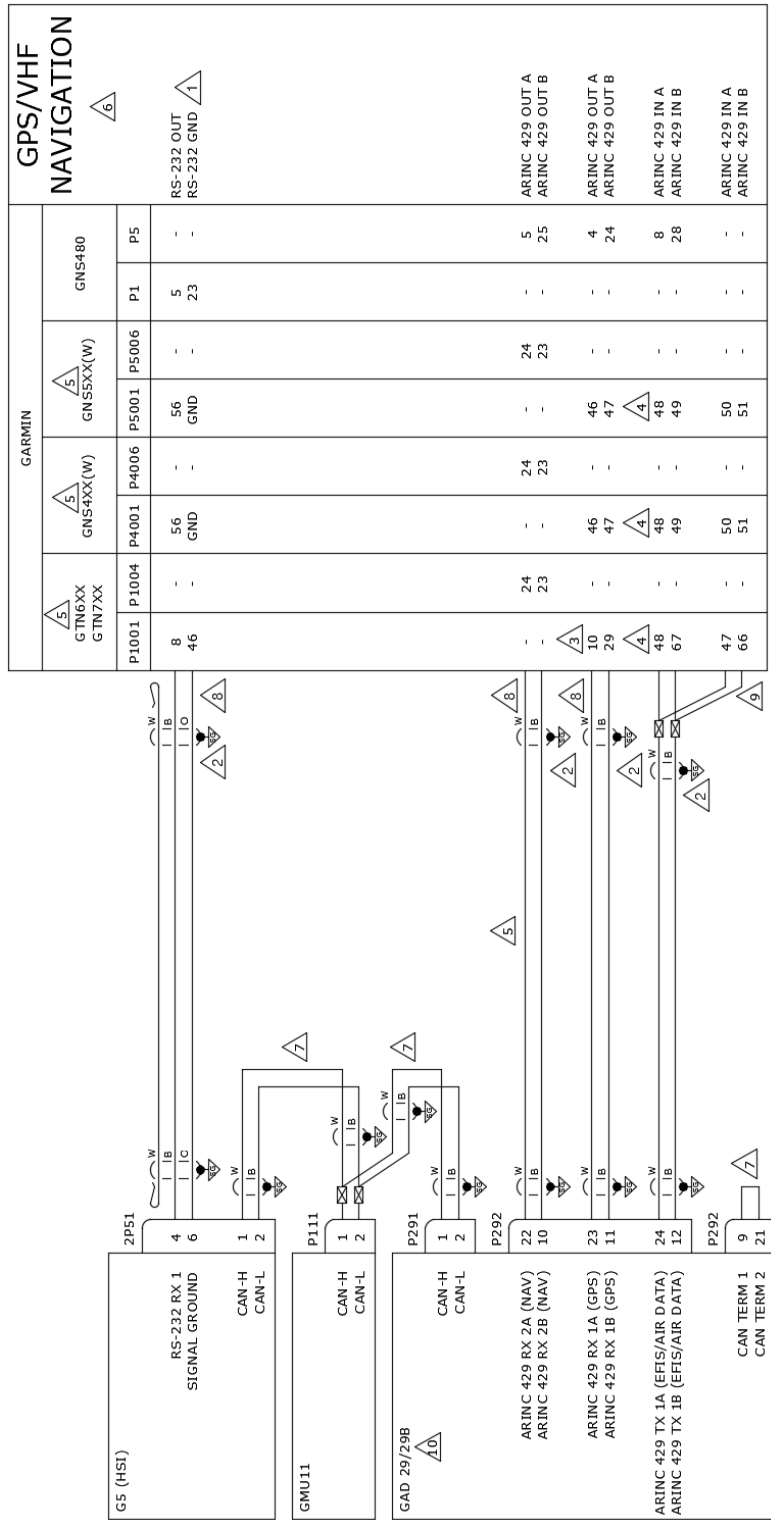

Figure 5-8 G5 (HSI) with GPS/VHF Navigator



- 1 CONNECT TO AN APPROPRIATELY CONFIGURED, AVAILABLE RS-232 PORT.
- 2 TERMINATE SHIELD GROUNDS TO CONNECTOR BACKSHELL. SHIELD LEADS MUST BE MAX 3.0 INCHES. REFER TO UNIT INSTALLATION MANUALS FOR MORE INFORMATION.
- 3 CONNECT TO ANY APPROPRIATELY CONFIGURED, AVAILABLE ARINC 429 OUT PORT.
- 4 CONNECT TO ANY APPROPRIATELY CONFIGURED, AVAILABLE ARINC 429 IN PORT.
- 5 ARINC 429 OUT (NAV) CONNECTION NOT APPLICABLE WHEN INTERFACING WITH GTN625/725 UNITS OR GNS4XX(W)/5XX(W) UNITS WITHOUT VHF NAVIGATION.
- 6 THIS STC DOES NOT APPROVE A CDI INTERFACED WITH THE SAME NAVIGATOR AS THE G5. REMOVE ANY EXISTING CDI INTERFACED WITH THIS NAVIGATOR.
- 7 REFER TO CAN BUS TERMINATION SECTION FOR FURTHER CAN BUS INFORMATION.
- 8 IT IS ACCEPTABLE TO SPLICE WIRES TO EXISTING WIRING.
- 9 CONNECTION ONLY REQUIRED WHEN INTERFACING TO A THIRD-PARTY AUTOPILOT EXCEPT GARMIN GFC600.
- 10 GAD29B INSTALLED WHEN INTERFACING TO A THIRD-PARTY AUTOPILOT. SEE GAD29B INTERFACE TO THIRD-PARTY AUTOPILOT INTERCONNECT DIAGRAMS FOR FURTHER INFORMATION.

Figure 5-9 G5 (HSI) with GPS/VHF Navigator Notes

5.8.1 G5 HSI Configuration (With GPS/VHF Navigator)

Config Page	Config Option	Configuration Setting
Device Information	Installation Type	Standalone Instrument
	Diagnostics/Data Log	Enabled
Attitude Configuration	Indicator Type	Normal
	Pitch Display	Normal
	Roll Display	For Fixed Type Pointers G5 Config = Ground or For Movable Type Pointers G5 Config = Sky
	User Pitch Offset	Disabled
	Automatic Declutter	Disabled
Air Data	Air Data Sensors	Enabled
	Vertical Speed Indicator	(1)(2)
Airspeed Note: Configure Units prior to setting airspeeds.	VNE	(1)(2)(3)
	VNO	(1)(2)(3)
	VSO	(1)(2)(3)
	VS1	(1)(2)(3)
	VFE	(1)(2)(3)
	VA	(1)(2)(3)
	VX	(1)(2)(3)
	VY	(1)(2)(3)
	VG	(1)(2)(3)
	VR	(1)(2)(3)
	VMC	(1)(2)(3)
VYSE	(1)(2)(3)	
Magnetometer	Magnetometer	Enabled
	Orientation	Connector Aft Or Connector Forward Or Connector Port Or Connector Starboard



Config Page	Config Option	Configuration Setting
Flight Controls	Autopilot Servos	None or See Section 5.12 if a Third Party Autopilot is interfaced
Backlight	Current Mode	Automatic
	Default Mode	Automatic
	Minimum Photocell Input	Default
	Minimum Display Brightness	Default
	Maximum Photocell Input	Default
	Maximum Display Brightness	Default
	Filter Time Constant	Default
Display	HSI Page	Enabled
	Power Up Page	HSI
Battery	Show Battery Status	When Using Battery
	Automatic Power Off	On Ground Only
GPS	Internal GPS Receiver	Disabled
	GPS Data Fields Note: This configuration Item is only present when RS-232 Input Format is configured for MapMX	Show
Navigation Note: This configuration Page is only present when RS-232 Input Format is configured for MapMX Note: If a third party autopilot interface is configured ON, this configuration page is set to ENABLED by default.	Navigation Data	Enabled (4)
Units	Altitude	(1)(2)
	Distance	(1)(2)
	Airspeed	(1)(2)(3)
	Ground Speed	(1)(2)
	Ground Track	Magnetic
	Vertical Speed	(1)(2)
	Pressure	(1)(2)
	Data Field Units Display	Alternate
RS-232	Input Format	MapMx (WAAS Units) AVIATION (Non WAAS Units)
	Output Format	None
ARINC 429	Output 1	EFIS / AIRDATA 1 (SDI 1) (Only used with GTN 6XX / 7XX and GNS 4XX(W) / 5XX(W) and no Third Party Autopilot is interfaced)
		EFIS / AIRDATA 2 (SDI 1) (Always used with GNS 480 and GTN 6XX / 7XX and GNS 4XX(W) / 5XX(W) when Third Party Autopilot is interfaced)
	Output 2	None
	Input 1	Garmin GPS (SDI 1)
	Input 2	Garmin VOR/ILS (SDI 1) (4)
	Input 3	None
	Input 4	None
Exit Configuration Mode		



5.8.2 GTN 6XX/7XX Configuration

Config Page	Config Option	Configuration Setting
ARINC 429	ARINC 429 In (x) (x represents any available ARINC 429 Port)	Speed = Low Data = EFIS Format 2
	ARINC 429 In (x) (x represents any available ARINC 429 Port) (Only used when Third Party Autopilot is interfaced)	Speed = Low Data = GAD Format 1 (Only used when Third Party Autopilot is interfaced)
	ARINC 429 Out (x) (x represents any available ARINC 429 Port)	Speed = Low Data = GAMA Format 1
RS-232	RS-232 (x) (x represents any available RS-232 Port)	Input = MapMX Format 2 Output = MapMX Format 2
Main Indicator (Analog) Configuration	CDI Key	Enabled
	Selected Course for GPS	Allowed
	Selected Course for VLOC	Allowed
	V-Flag State	Normal
VOR/LOC/GS Configuration	Nav Radio	Enabled (4)
	ARINC 429 Configuration	Tx Speed = Low SDI = VOR/ILS 1
Main System	Heading Source Input	Not Connected This selection is made only if the GTN being interfaced to has no other Heading input.
	Altitude Source Input	Connected This selection is made only if the GTN being interfaced to has no other Altitude input.

5.8.3 GNS 4XX(W) / 5XX(W) Configuration

Config Page	Config Option	Configuration Setting
MAIN ARINC 429 CONFIG Page	IN (x) (x represents any available ARINC 429 Port)	Speed = Low Data = EFIS / Airdata
	IN (x) (x represents any available ARINC 429 Port) (Only used when Third Party Autopilot is interfaced)	Speed = Low Data = Garmin GAD 42 (Only used when Third Party Autopilot is interfaced)
	OUT	Speed = Low Data = GAMA 429
	VNAV	ENABLED
MAIN RS232 CONFIG Page	RS-232 (x) (x represents any available RS-232 Channel)	Input = OFF Output = MapMX (WAAS) AVIATION (Non WAAS)
VOR/LOC/GS ARINC 429 CONFIG Page	SPEED	RX = Low TX = Low (4)
	SDI	VOR/ILS 1 (4)



5.8.4 GNS 480 Configuration

Config Page	Config Option	Configuration Setting
GND Maint Serial Setup	CH (x) (x represents any available Serial Channel)	Output = MapMX
GND Maint ARINC 429 Setup	CH In (2) (or any available 429 Port)	SEL = EFIS SPEED = Low SDI = SYS1
	CH Out (1) (or any available 429 Port)	SEL = GAMA 429 SPEED = Low SDI = SYS1
	CH Out (2) (or any available 429 Port)	SEL = VOR / ILS SPEED = Low SDI = SYS1
GND Maint Resolver Interface Setup	Resolver	Not Installed
GND Maint Miscellaneous Setup	CDI Select	Use

Note 1: Set configuration values and units to match the values indicated in the appropriate AFM and document settings in the space provided.

Note 2: If the aircraft has no AFM set the values as determined by the existing placards, instrument bugs or instrument markings.

Note 3: Existing placards related to airspeed limitations must be retained.

Note 4: Not applicable to GPS navigators that has no VHF Navigation output. Reference Note 5 in Figure 5-9.

This area intentionally blank

5.9 Dual G5 without Navigator

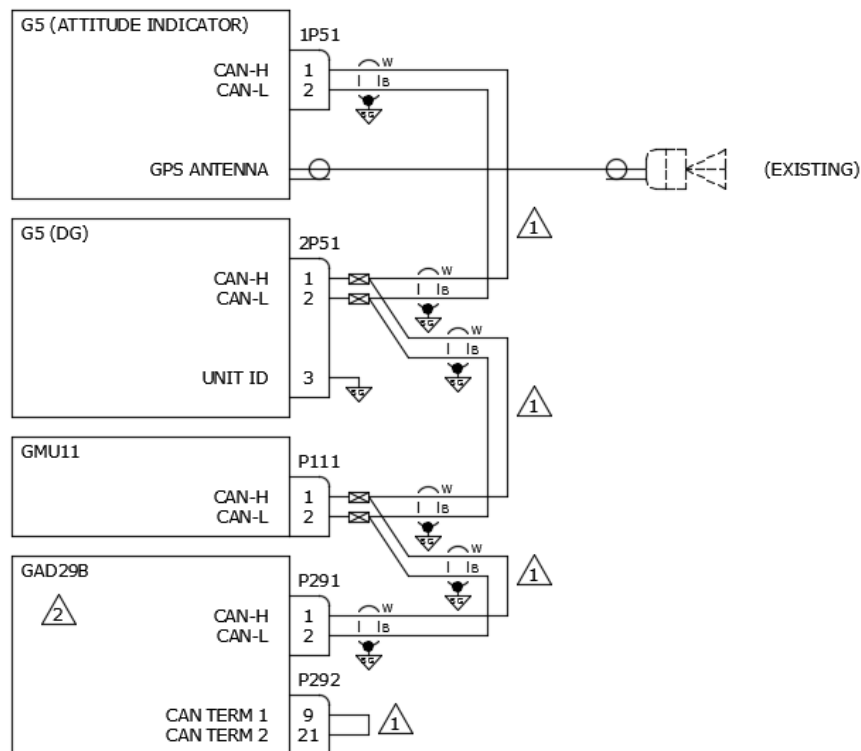

1 REFER TO CAN BUS TERMINATION SECTION FOR FURTHER CAN BUS INFORMATION.

2 GAD29B ONLY INSTALLED WHEN INTERFACING WITH THIRD-PARTY AUTOPILOTS. SEE GAD29B INTERFACE TO THIRD-PARTY AUTOPILOT INTERCONNECT DIAGRAMS FOR FURTHER INFORMATION.

Figure 5-10 Dual G5 without Navigator

5.9.1 Attitude Indicator Configuration

Config Page	Config Option	Configuration Setting
Device Information	Installation Type	Standalone Instrument
	Diagnostics/Data Log	Enabled
Attitude Configuration	Indicator Type	Normal
	Pitch Display	Normal
	Roll Display	For Fixed Type Pointers G5 Config = Ground or For Movable Type Pointers G5 Config = Sky
	User Pitch Offset	Disabled
	Automatic Declutter	Enabled
Air Data	Air Data Sensors	Enabled
	Vertical Speed Indicator	(1)(2)
Airspeed	VNE	(1)(2)(3)
Note: Configure Units prior to setting airspeeds.	VNO	(1)(2)(3)
	VSO	(1)(2)(3)
	VS1	(1)(2)(3)
	VFE	(1)(2)(3)
	VA	(1)(2)(3)
	VX	(1)(2)(3)



Config Page	Config Option	Configuration Setting
	VY	(1)(2)(3)
	VG	(1)(2)(3)
	VR	(1)(2)(3)
	VMC	(1)(2)(3)
	VYSE	(1)(2)(3)
Magnetometer	Magnetometer Orientation	Enabled Connector Aft Or Connector Forward Or Connector Port Or Connector Starboard
Flight Controls	Autopilot Servos	None or See Section 5.12 if a Third Party Autopilot is interfaced
Backlight	Current Mode	Automatic
	Default Mode	Automatic
	Minimum Photocell Input	Default
	Minimum Display Brightness	Default
	Maximum Photocell Input	Default
	Maximum Display Brightness	Default
	Filter Time Constant	Default
Display	HSI Page	Disabled
	Power Up Page	PFD
Battery	Show Battery Status	When Using Battery
	Automatic Power Off	On Ground Only
GPS	Internal GPS Receiver	Enabled
	GPS Data Fields	Show
Units	Altitude	(1)(2)
	Airspeed	(1)(2)(3)
	Ground Speed	(1)(2)
	Ground Track	Magnetic
	Vertical Speed	(1)(2)
	Pressure	(1)(2)
	Data Field Units Display	Alternate
RS-232	Input Format	None
	Output Format	None
ARINC 429	Output 1	None
	Output 2	None
	Input 1	None
	Input 2	None
	Input 3	None
	Input 4	None
Exit Configuration Mode		



5.9.2 G5 DG Configuration

Config Page	Config Option	Configuration Setting
Device Information	Installation Type	Standalone Instrument
	Diagnostics/Data Log	Enabled
Attitude Configuration	Pitch Display	Normal
	Roll Display	For Fixed Type Pointers G5 Config = Ground or For Movable Type Pointers G5 Config = Sky
	User Pitch Offset	Disabled
	Automatic Declutter	Disabled
Air Data	Air Data Sensors	Enabled
	Vertical Speed Indicator	(1)(2)
Backlight	Current Mode	Automatic
	Default Mode	Automatic
	Minimum Photocell Input	Default
	Minimum Display Brightness	Default
	Maximum Photocell Input	Default
	Maximum Display Brightness	Default
	Filter Time Constant	Default
Display	HSI Page	Enabled
	Power Up Page	HSI
Battery	Show Battery Status	When Using Battery
	Automatic Power Off	On Ground Only
GPS	Internal GPS Receiver	Disabled
	GPS Data Fields	Show
RS-232	Input Format	None
	Output Format	None
Exit Configuration Mode		

This area intentionally blank

5.10 Dual G5 with VHF Navigator

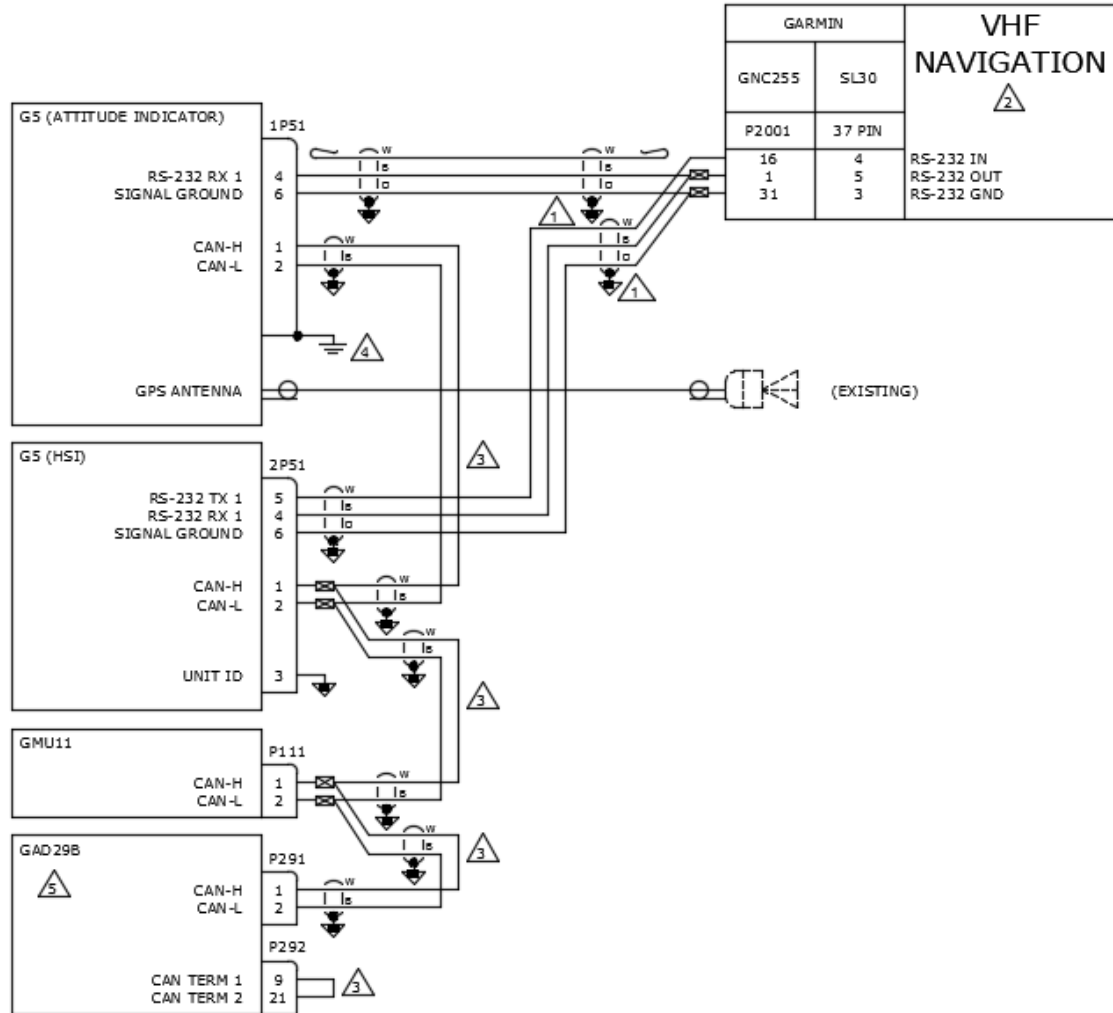

- 1 TERMINATE SHIELD GROUNDS TO CONNECTOR BACKSHELL. SHIELD LEADS MUST BE MAX 3.0 INCHES. REFER TO UNIT INSTALLATION MANUALS FOR MORE INFORMATION.
- 2 THIS STC DOES NOT APPROVE A CDI INTERFACED WITH THE SAME NAVIGATOR AS THE G5. REMOVE ANY EXISTING CDI INTERFACED WITH THIS NAVIGATOR.
- 3 REFER TO CAN BUS TERMINATION SECTION FOR FURTHER CAN BUS INFORMATION.
- 4 CONNECT BACKSHELL OF CONNECTOR 1P51 TO AIRCRAFT GROUND USING 1/4" BRAID (P/N QQ8575F36T0250, 8 INCHES MAX LENGTH) AND RING TERMINALS (P/N MS25036-108).
- 5 GAD29B ONLY INSTALLED WHEN INTERFACING WITH THIRD-PARTY AUTOPILOTS. SEE GAD29B INTERFACE TO THIRD-PARTY AUTOPILOT INTERCONNECT DIAGRAMS FOR FURTHER INFORMATION.

Figure 5-11 Dual G5 with VHF Navigator

5.10.1 Attitude Indicator Configuration

Config Page	Config Option	Configuration Setting
Device Information	Installation Type	Standalone Instrument
	Diagnostics/Data Log	Enabled
Attitude Configuration	Indicator Type	Normal
	Pitch Display	Normal



Config Page	Config Option	Configuration Setting
	Roll Display	For Fixed Type Pointers G5 Config = Ground or For Movable Type Pointers G5 Config = Sky
	User Pitch Offset	Disabled
	Automatic Declutter	Enabled
Air Data	Air Data Sensors	Enabled
	Vertical Speed Indicator	(1)(2)
Airspeed	VNE	(1)(2)(3)
Note: Configure Units prior to setting airspeeds.	VNO	(1)(2)(3)
	VSO	(1)(2)(3)
	VS1	(1)(2)(3)
	VFE	(1)(2)(3)
	VA	(1)(2)(3)
	VX	(1)(2)(3)
	VY	(1)(2)(3)
	VG	(1)(2)(3)
	VR	(1)(2)(3)
	VMC	(1)(2)(3)
	VYSE	(1)(2)(3)
Magnetometer	Magnetometer Orientation	Enabled Connector Aft Or Connector Forward Or Connector Port Or Connector Starboard
Flight Controls	Autopilot Servos	None or See Section 5.12 if a Third Party Autopilot is interfaced
Backlight	Current Mode	Automatic
	Default Mode	Automatic
	Minimum Photocell Input	Default
	Minimum Display Brightness	Default
	Maximum Photocell Input	Default
	Maximum Display Brightness	Default
	Filter Time Constant	Default
Display	HSI Page	Disabled
	Power Up Page	PFD
Battery	Show Battery Status	When Using Battery
	Automatic Power Off	On Ground Only
GPS	Internal GPS Receiver	Enabled
	GPS Data Fields	Show
Navigation Note: This configuration Page is only present when RS-232 Input Format is configured for Garmin VHF NAV Radio Note: If a third party autopilot interface is configured ON, this configuration page is set to ENABLED by default.	Navigation Data	Enabled
Units	Altitude	(1)(2)
	Airspeed	(1)(2)(3)



Config Page	Config Option	Configuration Setting
	Ground Speed	(1)(2)
	Ground Track	Magnetic
	Vertical Speed	(1)(2)
	Pressure	(1)(2)
	Data Field Units Display	Alternate
RS-232	Input Format	Garmin VHF NAV Radio
	Output Format	Garmin VHF NAV Radio
ARINC 429	Output 1	None
	Output 2	None
	Input 1	None
	Input 2	None
	Input 3	None
	Input 4	None
Exit Configuration Mode		

5.10.2 G5 HSI Configuration

Config Page	Config Option	Configuration Setting
Device Information	Installation Type	Standalone Instrument
	Diagnostics/Data Log	Enabled
Attitude Configuration	Pitch Display	Normal
	Roll Display	For Fixed Type Pointers G5 Config = Ground or For Movable Type Pointers G5 Config = Sky
	User Pitch Offset	Disabled
	Automatic Declutter	Disabled
Air Data	Air Data Sensors	Enabled
	Vertical Speed Indicator	(1)(2)
Backlight	Current Mode	Automatic
	Default Mode	Automatic
	Minimum Photocell Input	Default
	Minimum Display Brightness	Default
	Maximum Photocell Input	Default
	Maximum Display Brightness	Default
	Filter Time Constant	Default
Display	HSI Page	Enabled
	Power Up Page	HSI
Battery	Show Battery Status	When Using Battery
	Automatic Power Off	On Ground Only
GPS	Internal GPS Receiver	Disabled
	GPS Data Fields	Show
Navigation Note: This configuration Page is only present when RS-232 Input Format is configured for Garmin VHF NAV Radio Note: If a third party autopilot interface is configured ON, this configuration page is set to ENABLED by default.	Navigation Data	Enabled
RS-232	Input Format	Garmin VHF NAV Radio
	Output Format	Garmin VHF NAV Radio



Config Page	Config Option	Configuration Setting
Exit Configuration Mode		

5.10.3 GNC 255 Configuration

Config Page	Config Option	Configuration Setting
Sys Configuration	RS 232 Serial Port	IO Mode = NMEA
Attitude Configuration	CDI Indicator	TYPE = Serial

5.10.4 SL30 Configuration

Config Page	Config Option	Configuration Setting
Sys Configuration	RS 232 Serial Port	No Setting
Attitude Configuration	Indicator Type	TYPE = Serial

Note 1: Set configuration values and units to match the values indicated in the appropriate AFM and document settings in the space provided.

Note 2: If the aircraft has no AFM set the values as determined by the existing placards, instrument bugs or instrument markings.

Note 3: Existing placards related to airspeed limitations must be retained.

This area intentionally blank

5.11 Dual G5 with GPS/VHF Navigator

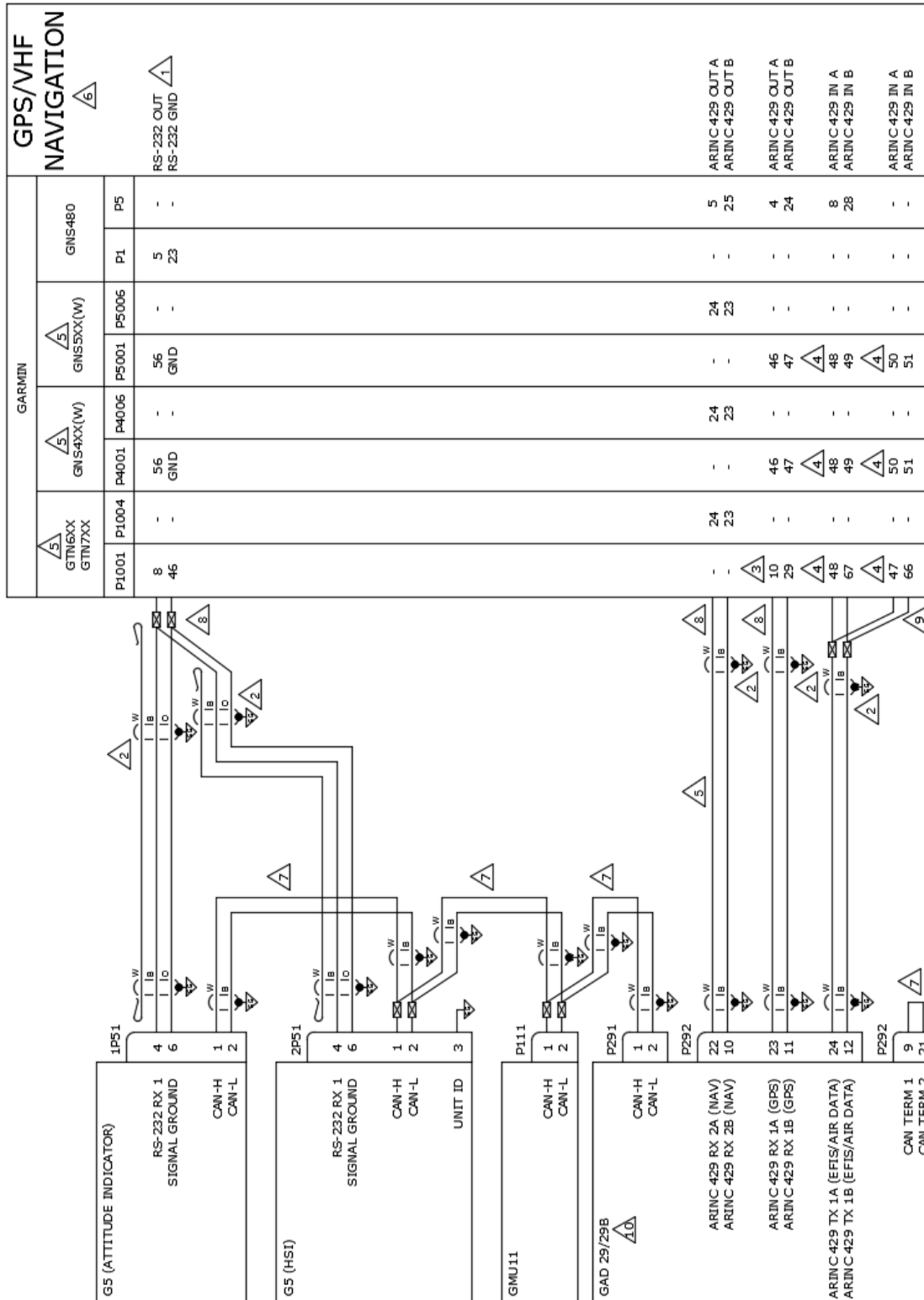

Figure 5-12 Dual G5 with GPS/VHF Navigator



- 1 CONNECT TO AN APPROPRIATELY CONFIGURED, AVAILABLE RS-232 PORT.
- 2 TERMINATE SHIELD GROUNDS TO CONNECTOR BACKSHELL. SHIELD LEADS MUST BE MAX 3.0 INCHES. REFER TO UNIT INSTALLATION MANUALS FOR MORE INFORMATION.
- 3 CONNECT TO ANY APPROPRIATELY CONFIGURED, AVAILABLE ARINC 429 OUT PORT.
- 4 CONNECT TO ANY APPROPRIATELY CONFIGURED, AVAILABLE ARINC 429 IN PORT.
- 5 ARINC 429 OUT (NAV) CONNECTION NOT APPLICABLE WHEN INTERFACING WITH GTN625/725 UNITS OR GNS4XX(W)/5XX(W) UNITS WITHOUT VHF NAVIGATION.
- 6 THIS STC DOES NOT APPROVE A CDI INTERFACED WITH THE SAME NAVIGATOR AS THE G5. REMOVE ANY EXISTING CDI INTERFACED WITH THIS NAVIGATOR.
- 7 REFER TO CAN BUS TERMINATION SECTION FOR FURTHER CAN BUS INFORMATION.
- 8 IT IS ACCEPTABLE TO SPLICE WIRES TO EXISTING WIRING.
- 9 CONNECTION ONLY REQUIRED WHEN INTERFACING TO A THIRD-PARTY AUTOPILOT EXCEPT GARMIN GFC600.
- 10 GAD29B INSTALLED WHEN INTERFACING TO A THIRD-PARTY AUTOPILOT. SEE GAD29B INTERFACE TO THIRD-PARTY AUTOPILOT INTERCONNECT DIAGRAMS FOR FURTHER INFORMATION.

Figure 5-13 Dual G5 with GPS/VHF Navigator Notes

5.11.1 Attitude Indicator Configuration

Config Page	Config Option	Configuration Setting
Device Information	Installation Type	Standalone Instrument
	Diagnostics/Data Log	Enabled
Attitude Configuration	Indicator Type	Normal
	Pitch Display	Normal
	Roll Display	For Fixed Type Pointers G5 Config = Ground or For Movable Type Pointers G5 Config = Sky
	User Pitch Offset	Disabled
	Automatic Declutter	Enabled
Air Data	Air Data Sensors	Enabled
	Vertical Speed Indicator	(1)(2)
Airspeed Note: Configure Units prior to setting airspeeds.	VNE	(1)(2)(3)
	VNO	(1)(2)(3)
	VSO	(1)(2)(3)
	VS1	(1)(2)(3)
	VFE	(1)(2)(3)
	VA	(1)(2)(3)
	VX	(1)(2)(3)
	VY	(1)(2)(3)
	VG	(1)(2)(3)
	VR	(1)(2)(3)
	VMC	(1)(2)(3)
VYSE	(1)(2)(3)	
Magnetometer	Magnetometer	Enabled
	Orientation	Connector Aft Or Connector Forward Or Connector Port Or Connector Starboard



Config Page	Config Option	Configuration Setting
Flight Controls	Autopilot Servos	None or See Section 5.12 if a Third Party Autopilot is interfaced
Backlight	Current Mode	Automatic
	Default Mode	Automatic
	Minimum Photocell Input	Default
	Minimum Display Brightness	Default
	Maximum Photocell Input	Default
	Maximum Display Brightness	Default
	Filter Time Constant	Default
Display	HSI Page	Disabled
	Power Up Page	PFD
Battery	Show Battery Status	When Using Battery
	Automatic Power Off	On Ground Only
GPS	Internal GPS Receiver	Disabled
	GPS Data Fields Note: This configuration item is only present when RS-232 Input Format is configured for MapMX	Show
Navigation Note: This configuration Page is only present when RS-232 Input Format is configured for MapMX Note: If a third party autopilot interface is configured ON, this configuration page is set to ENABLED by default.	Navigation Data	Enabled
Units	Altitude	(1)(2)
	Distance	(1)(2)
	Airspeed	(1)(2)(3)
	Ground Speed	(1)(2)
	Ground Track	Magnetic
	Vertical Speed	(1)(2)
	Pressure	(1)(2)
	Data Field Display	Alternate
RS-232	Input Format	MapMx (WAAS Units) AVIATION (Non WAAS Units)
	Output Format	None
ARINC 429	Output 1	EFIS / AIRDATA 1 (SDI 1) (Only used with GTN 6XX / 7XX and GNS 4XX(W) / 5XX(W) and no Third Party Autopilot is interfaced)
		EFIS / AIRDATA 2 (SDI 1) (Always used with GNS 480 and GTN 6XX / 7XX and GNS 4XX(W) / 5XX(W) when Third Party Autopilot is interfaced)
	Output 2	None
	Input 1	Garmin GPS (SDI 1)
	Input 2	Garmin VOR/ILS (SDI 1)
	Input 3	None
	Input 4	None
	Exit Configuration Mode	



5.11.2 HSI Configuration

Config Page	Config Option	Configuration Setting
Device Information	Installation Type	Standalone Instrument
	Diagnostics/Data Log	Enabled
Attitude Configuration	Pitch Display	Normal
	Roll Display	For Fixed Type Pointers G5 Config = Ground or For Movable Type Pointers G5 Config = Sky
	User Pitch Offset	Disabled
	Automatic Declutter	Disabled
Air Data	Air Data Sensors	Enabled
	Vertical Speed Indicator	(1)(2)
Backlight	Current Mode	Automatic
	Default Mode	Automatic
	Minimum Photocell Input	Default
	Minimum Display Brightness	Default
	Maximum Photocell Input	Default
	Maximum Display Brightness	Default
	Filter Time Constant	Default
Display	HSI Page	Enabled
	Power Up Page	HSI
Battery	Show Battery Status	When Using Battery
	Automatic Power Off	On Ground Only
GPS	Internal GPS Receiver	Disabled
	GPS Data Fields	Show
Navigation	Navigation Data	Enabled
<p>Note: This configuration Page is only present when RS-232 Input Format is configured for MapMX</p> <p>Note: If a third party autopilot interface is configured ON, this configuration page is set to ENABLED by default.</p>		
Units	Ground Track	Magnetic
	Data Field Units Display	Alternate
RS-232	Input Format	MapMX (WAAS Units) AVIATION (non WAAS Units)
	Output Format	None
Exit Configuration Mode		



5.11.3 GTN 650/750 Configuration

Config Page	Config Option	Configuration Setting
ARINC 429	ARINC 429 In (x) (x represents any available ARINC 429 Port)	Speed = Low Data = EFIS Format 2
	ARINC 429 In (x) (x represents any available ARINC 429 Port) (Only used when Third Party Autopilot is interfaced)	Speed = Low Data = GAD Format 1 (Only used when Third Party Autopilot is interfaced)
	ARINC 429 Out (x) (x represents any available ARINC 429 Port)	Speed = Low Data = GAMA Format 1
	SDI	LNAV1
RS-232	RS-232 (x) (x represents any available RS-232 Port)	Input = MapMX Format 2 Output = MapMX Format 2
Main Indicator (Analog) Configuration	CDI Key	Enabled
	Selected Course for GPS	Allowed
	Selected Course for VLOC	Allowed
	V-Flag State	Normal
VOR/LOC/GS Configuration	Nav Radio	Enabled
	ARINC 429 Configuration	Tx Speed = Low SDI = VOR/ILS 1
Main System	Heading Source Input	Not Connected This selection is made only if the GTN being interfaced to has no other Heading input.
	Altitude Source Input	Connected This selection is made only if the GTN being interfaced to has no other Altitude input.

5.11.4 GNS 4XX(W) / 5XX(W) Configuration

Config Page	Config Option	Configuration Setting
MAIN ARINC 429 CONFIG Page	IN (x) (x represents any available ARINC 429 Port)	Speed = Low Data = EFIS / Airdata
	IN (x) (x represents any available ARINC 429 Port) (Only used when Third Party Autopilot is interfaced)	Speed = Low Data = Garmin GAD 42 (Only used when Third Party Autopilot is interfaced)
	OUT	Speed = Low Data = GAMA 429
	VNAV	ENABLED
MAIN RS232 CONFIG Page	RS-232 (x) (x represents any available RS-232 Channel)	Input = OFF Output = MapMX (WAAS) AVIATION (Non WAAS)
VOR/LOC/GS ARINC 429 CONFIG Page	SPEED	RX = Low TX = Low
	SDI	VOR/ILS 1



5.11.5 GNS 480 Configuration

Config Page	Config Option	Configuration Setting
GND Maint Serial Setup	CH (x) (x represents any available Serial Channel)	Output = MapMX
GND Maint ARINC 429 Setup	CH In (2) (or any available 429 Port)	SEL = EFIS SPEED = Low SDI = SYS1
	CH Out (1) (or any available 429 Port)	SEL = GAMA 429 SPEED = Low SDI = SYS1
	CH Out (2) (or any available 429 Port)	SEL = VOR / ILS SPEED = Low SDI = SYS1
GND Maint Resolver Interface Setup	Resolver	Not Installed
GND Maint Miscellaneous Setup	CDI Select	Use

Note 1: Set configuration values and units to match the values indicated in the appropriate AFM and document settings in the space provided.

Note 2: If the aircraft has no AFM set the values as determined by the existing placards, instrument bugs or instrument markings.

Note 3: Existing placards related to airspeed limitations must be retained.

This area intentionally blank



5.12 GAD 29B Interface to Third-Party Autopilots

This section only applies to installations using a GAD 29B data converter and an interface to one of the autopilots listed in Table 5-1. Specific configuration details are covered in the following sections.

Table 5-1: Third-Party Autopilots

Autopilot Mfg	Autopilot Model
Century	Century 1C388*
	Century 1C388M*
	Century 1C388C*
	Century 1C388MC*
	Century 1C388-2*
	Century 1C388-3*
	Century 2000
	Century 21
	Century 31
	Century 41
	Century IV
	* Radio Coupler P/N indicated and based on aircraft installation could be interfaced in a Century I, II or III.
Cessna	Cessna 300, 400 & 800 IFCS
	Cessna 300B, 400B & 800B IFCS
Garmin	GFC 600
Honeywell (Bendix /King)	Bendix King KAP 100
	Bendix King KAP 140
	Bendix King KAP 150
	Bendix King KAP 200
	Bendix King KFC 150
	Bendix King KFC 200
	Bendix King KFC 225
S-TEC	S-TEC System 20
	S-TEC System 30
	S-TEC System 40
	S-TEC System 50
	S-TEC System 55
	S-TEC System 55X
	S-TEC System 60
	S-TEC System 65

This area intentionally blank

5.12.1 GAD 29B Interface to Century Autopilots

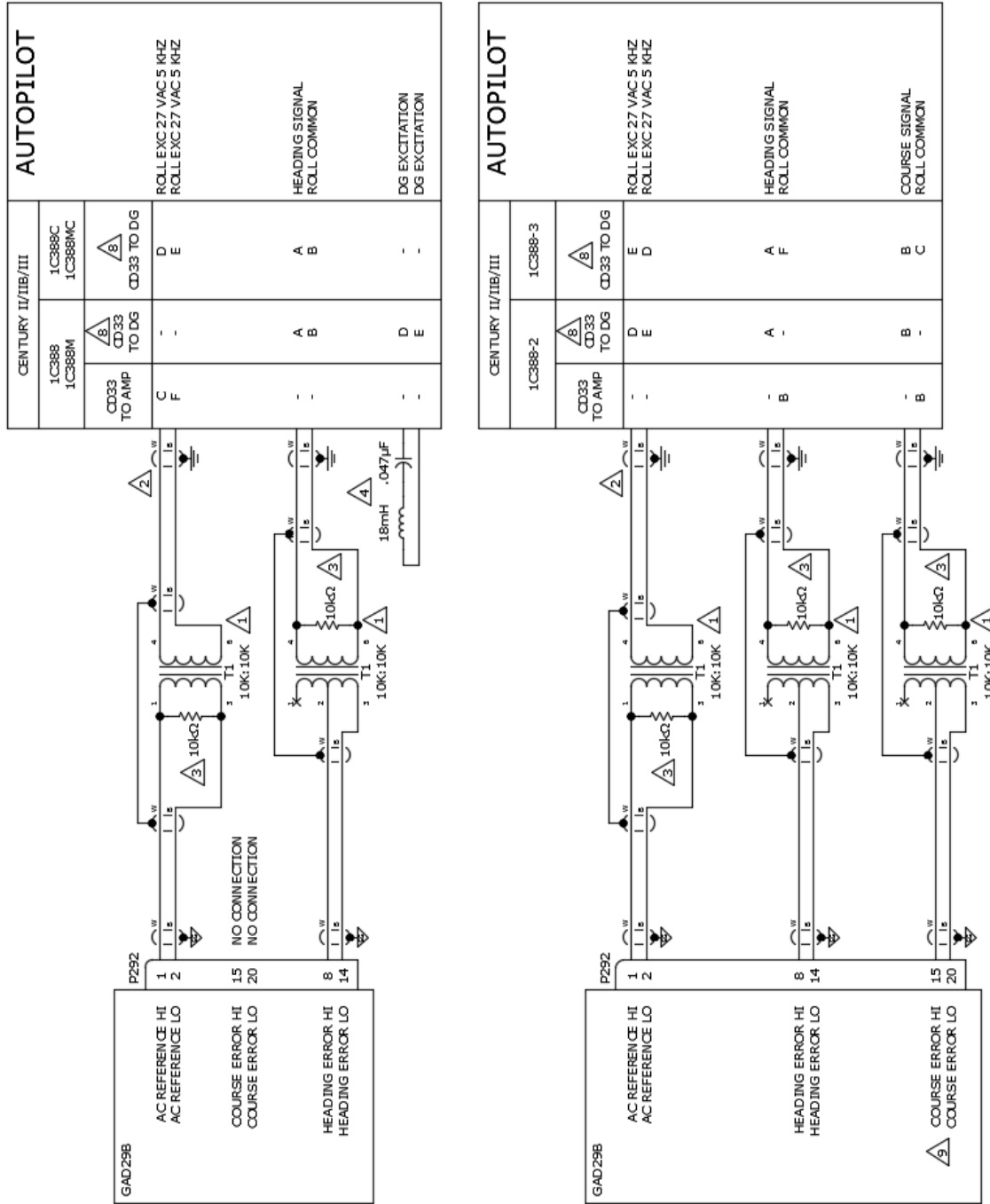
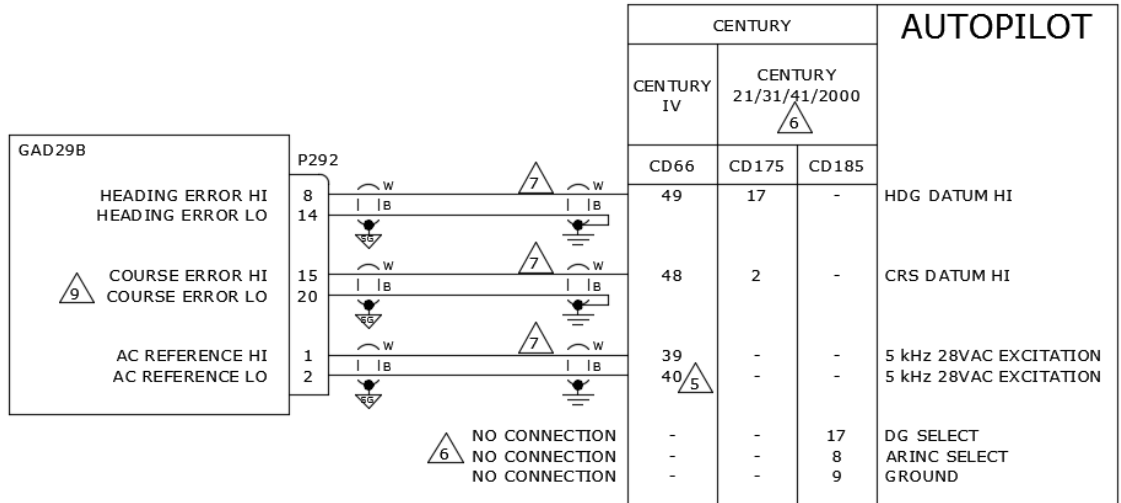
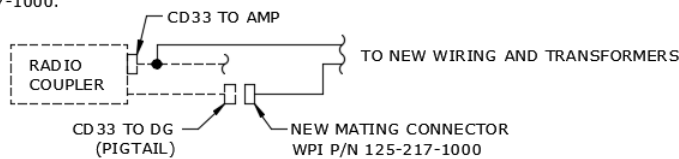

Figure 5-14 GAD 29B Interface to Century Autopilots Sheet 1 of 2



- 1 USE MIL-T-27 TYPE TF5S21ZZ TRANSFORMER TRIAD MAGNETICS P/N SP-66. REFER TO GAD29B TRANSFORMER MOUNTING INSTRUCTIONS FOR TRANSFORMER MOUNTING AND INSTALLATION INSTRUCTIONS.
- 2 SPLICE NEW WIRING TO EXISTING WIRING AT RADIO COUPLER.
- 3 USE MIL-R-10509 TYPE RN RESISTOR VISHAY P/N RN60D1002FB14.
- 4 USE CENTURY TANK CIRCUIT (CENTURY P/N 24A93) OR INDUCTOR JW MILLER P/N 8250-183K-RC AND MIL-PRF-39014 CAPACITOR KEMET P/N CKR05BX473M.
- 5 THE 5kHz EXCITATION SIGNAL IS NEEDED WHEN INTERFACING WITH AN AC CENTURY IV AUTOPILOT.
- 6 WHEN INTERFACING WITH A CENTURY 31/41 A/P, REMOVE ALL JUMPERS AT CD185 PINS 8, 9, AND 17.
- 7 EXISTING WIRING MAY BE RE-USED IF WIRE LENGTH IS SUFFICIENT TO REACH GAD29B.
- 8 FOR CONNECTIONS TO "CD33 TO DG" PIGTAIL AT RADIO COUPLER, BUILD MATING CONNECTOR USING WPI P/N 125-217-1000.



- 9 COURSE ERROR OUT IS ONLY CONNECTED WHEN THE G5 IS INTERFACING WITH A GPS/VHF NAVIGATOR.

Figure 5-15 GAD 29B Interface to Century Autopilots Sheet 2 of 2

This area intentionally blank



5.12.1.1 G5 Configuration Century Autopilots

Note: The Flight Controls Configuration shown below only needs to be set on the master G5. In a single installation the master must be the G5 DG/HSI. In a dual installation the master is the G5 Attitude indicator.

Config Page	Config Option	Configuration Setting		Interfacing Equipment Configuration Information
Flight Controls	Analog Autopilot Interface	AP Model / Radio Coupler P/N	G5 Config	Century A/P Config
		1C388	Century 1C388	As per the wiring interface in Figure 5-14 & Figure 5-15
		1C388-2	Century 1C388-2	
		1C388-3	Century 1C388-3	
		1C388C	Century 1C388C	
		1C388M	Century 1C388M	
		1C388MC	Century 1C388MC	
		Century 2000	Century 2000	
		Century 21	Century 21	
		Century 31	Century 31	
		Century 41	Century 41	
	Century IV (DC)	Century IV		
		GPS Steering*	Enabled	
	GPSS Scale Factor*	1.00		---
* GPS Steering and GPSS Scale Factor is configured the same for all listed Analog Autopilot interfaces				---

This area intentionally blank

5.12.2 GAD 29B Interface to Cessna Autopilots

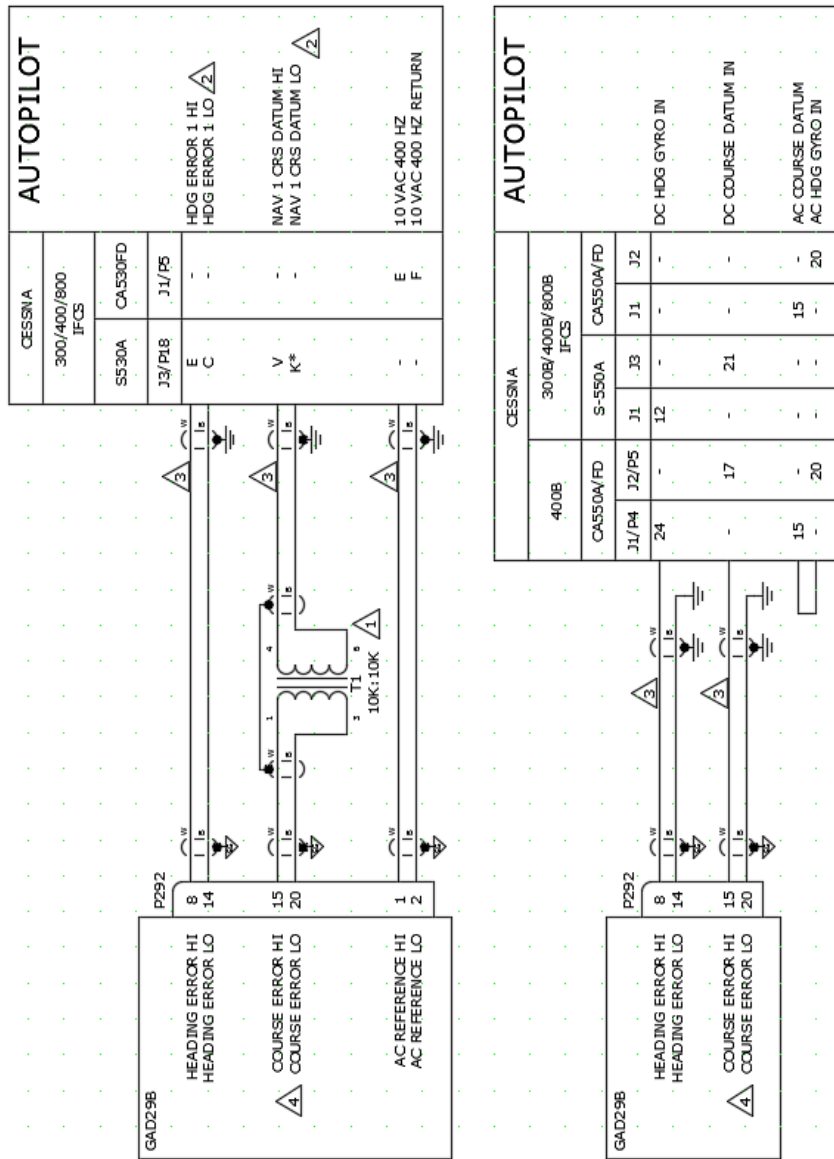

Figure 5-16 GAD 29B Interface to Cessna Autopilots Sheet 1 of 2

- 1 USE MIL-T-27 TYPE TF5S21ZZ TRANSFORMER TRIAD MAGNETICS P/N SP-66. REFER TO GAD29B TRANSFORMER MOUNTING INSTRUCTIONS FOR TRANSFORMER MOUNTING AND INSTALLATION INSTRUCTIONS.
- 2 TUNE RESISTANCE POTS ON HEADING ERROR HI AND COURSE ERROR HI TO END OF TRAVEL IN ORDER NOT TO AFFECT THE HEADING AND COURSE ERROR SIGNALS. REFER TO CESSNA 300/400/800 IFCS MAINTENANCE MANUAL FOR FURTHER INFORMATION.
- 3 EXISTING WIRING MAY BE RE-USED IF WIRE LENGTH IS SUFFICIENT TO REACH GAD29B.
- 4 COURSE ERROR OUT IS ONLY CONNECTED WHEN THE G5 IS INTERFACING WITH A GPS/VHF NAVIGATOR.

Figure 5-17 GAD 29B Interface to Cessna Autopilots Sheet 2 of 2



5.12.2.1 G5 Configuration Cessna Autopilots

Note: The Flight Controls Configuration shown below only needs to be set on the master G5. In a single installation the master is the only G5 indicator installed. In a dual installation the master is the G5 Attitude indicator.

Config Page	Config Option	Configuration Setting		Interfacing Equipment Configuration Information
Flight Controls	Analog Autopilot Interface	AP Model	G5 Config	Cessna A/P Config As per wiring interface in Figure 5-16 & Figure 5-17
		Cessna 300 IFCS	Cessna 300 (AC)	
		Cessna 400 & 800 IFCS	Cessna 400 (AC)	
		Cessna 300B IFCS	Cessna 300 (DC)	
	Cessna 400B & 800B IFCS	Cessna 400 (DC)		
	GPS Steering*	Enabled		---
GPSS Scale Factor*	1.00			

* GPS Steering and GPSS Scale Factor is configured the same for all listed Analog Autopilot interfaces

This area intentionally blank

5.12.3 GAD 29B Interface to Garmin GFC 600 Autopilot

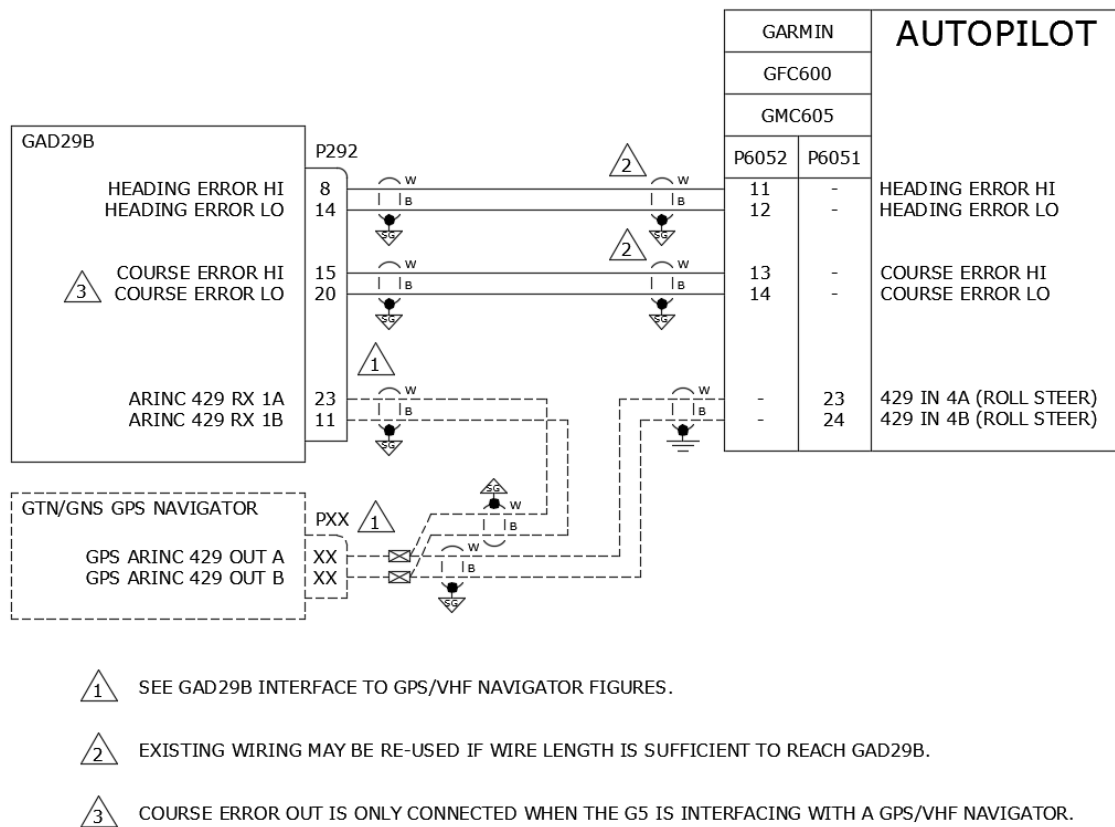

Figure 5-18 GAD 29B Interface to Garmin Autopilots

5.12.3.1 G5 Configuration GFC 600 Autopilots

Note: The Flight Controls Configuration shown below only needs to be set on the master G5. In a single installation the master is the only G5 indicator installed. In a dual installation the master is the G5 Attitude indicator.

Config Page	Config Option	Configuration Setting		Interfacing Equipment Configuration Information
Flight Controls	Analog Autopilot Interface	AP Model	G5 Config	GFC 600 A/P Config Config Item – HSI/DG Setting KI525
		GFC 600	Bendix King KI 525 HSI	
	GPS Steering*	Enabled		
	GPSS Scale Factor*	1.00		

* GPS Steering and GPSS Scale Factor is configured the same for all listed Analog Autopilot interfaces

5.12.4 GAD 29B Interface to Honeywell Autopilots

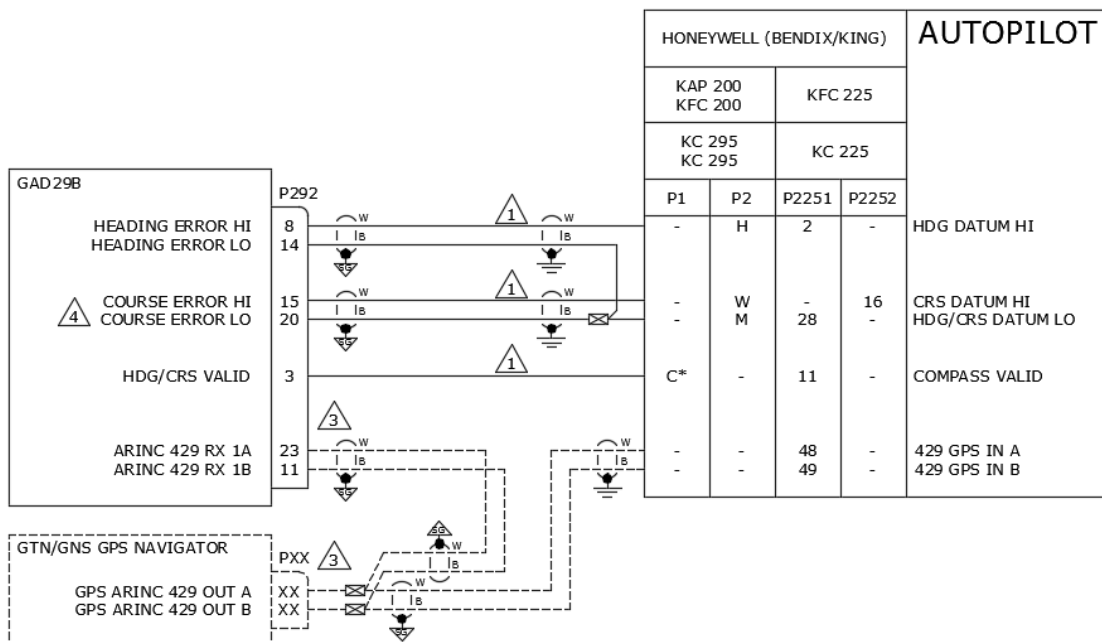
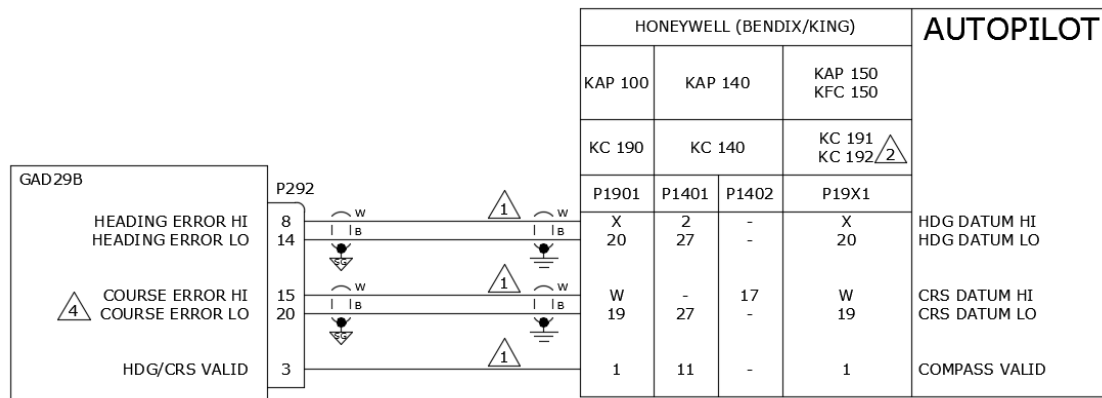

- 1 EXISTING WIRING MAY BE RE-USED IF WIRE LENGTH IS SUFFICIENT TO REACH GAD29B.
- 2 EFIS-ENABLED KC 19X COMPUTER (P/N 065-0042-16) IS NOT SUPPORTED.
- 3 SEE GAD29B INTERFACE TO GPS/VHF NAVIGATOR FIGURES.
- 4 COURSE ERROR OUT IS ONLY CONNECTED WHEN THE G5 IS INTERFACING WITH A GPS/VHF NAVIGATOR.

Figure 5-19 GAD 29B Interface to Honeywell Autopilots



5.12.4.1 G5 Configuration Honeywell (Bendix King) Autopilots

Note: The Flight Controls Configuration shown below only needs to be set on the master G5. In a single installation the master is the only G5 indicator installed. In a dual installation the master is the G5 Attitude indicator.

Config Page	Config Option	Configuration Setting		Interfacing Equipment Configuration Information
Flight Controls	Analog Autopilot Interface	AP Model	G5 Config	KAP/KFC A/P Config
		KAP 100	Bendix King KAP 100	Must be configured to operate with the KI-525 (KCS-55) heading system.
		KAP 140	Bendix King KAP 140	
		KAP 150	Bendix King KAP 150	
		KAP 200	Bendix King KAP 200	
		KFC 150	Bendix King KFC 150	
		KFC 200	Bendix King KFC 200	
	KFC 225 **	Bendix King KFC 225	Must be configured to operate with the KI-525 (KCS-55) heading system. Must be configured for DC analog heading	
GPS Steering*	Enabled		---	
GPSS Scale Factor*	1.00		---	
* GPS Steering and GPSS Scale Factor is configured the same for all listed Analog Autopilot interfaces except KFC 225 ** GPS Steering is not an available configuration for KFC 225				---

This area intentionally blank

5.12.5 GAD 29B Interface to S-TEC Autopilots

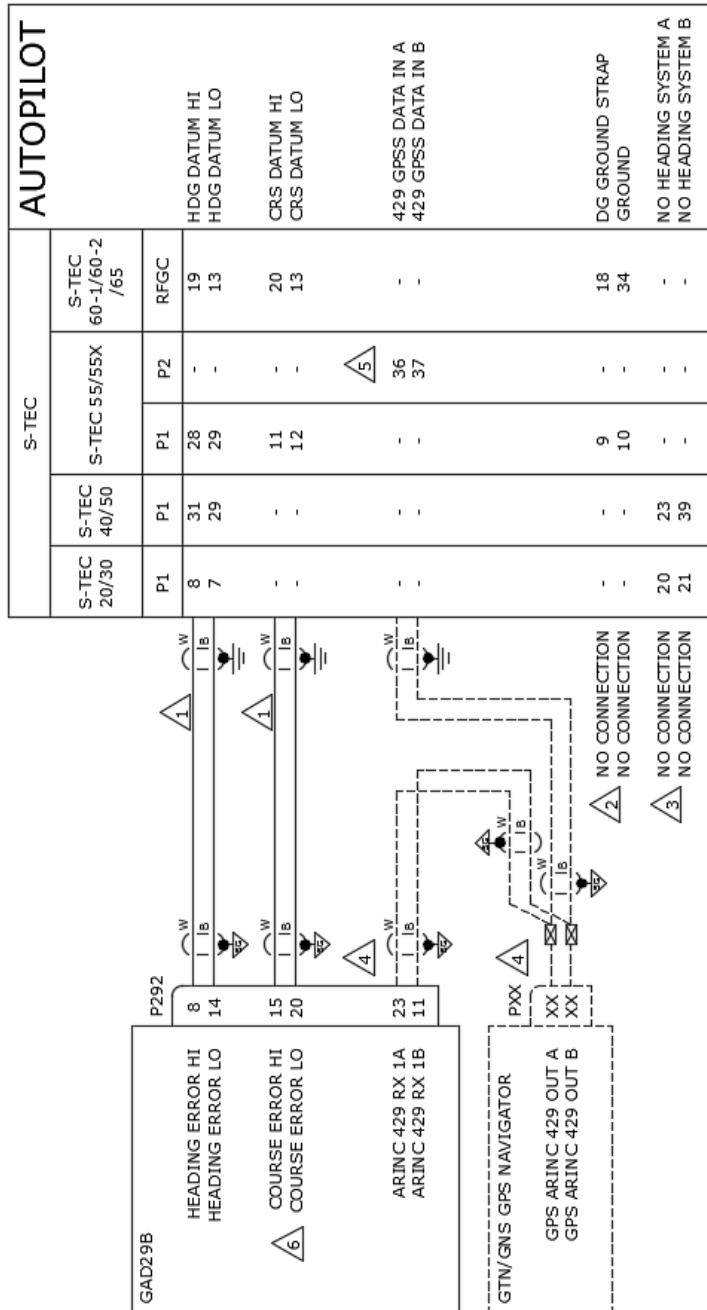

Figure 5-20 GAD 29B Interface to S-TEC Autopilots

5.12.5.1 G5 Configuration S-TEC Autopilots

Note: The Flight Controls Configuration shown below only needs to be set on the master G5. In a single installation the master is the only G5 indicator installed. In a dual installation the master is the G5 Attitude indicator.

- 1 EXISTING WIRING MAY BE RE-USED IF WIRE LENGTH IS SUFFICIENT TO REACH GAD29B.
- 2 REMOVE ALL JUMPERS FOR DG GROUND STRAP.
- 3 REMOVE ALL JUMPERS FOR NO HEADING SYSTEM.
- 4 SEE GAD29B INTERFACE TO GPS/VHF NAVIGATOR FIGURES.
- 5 429 GPSS DATA IN A/B APPLIES TO S-TEC 55X SYSTEM ONLY.
- 6 COURSE ERROR OUT IS ONLY CONNECTED WHEN THE G5 IS INTERFACING WITH A GPS/VHF NAVIGATOR.



Config Page	Config Option	Configuration Setting		Interfacing Equipment Configuration Information
Flight Controls	Analog Autopilot Interface	AP Model	G5 Config	S-TEC A/P Config Must be configured to operate with the KI-525 (KCS-55) heading system.
		System 20	S-TEC System 20	
		System 30	S-TEC System 30	
		System 40	S-TEC System 40	
		System 50	S-TEC System 50	
		System 55	S-TEC System 55	
		System 55X**	S-TEC System 55X	
		System 60	S-TEC System 60	
	System 65	S-TEC System 65		
		GPS Steering*	Enabled	
	GPSS Scale Factor*	1.00		
* GPS Steering and GPSS Scale Factor is configured the same for all listed Analog Autopilot interfaces except System 55X ** GPS Steering is not an available configuration for System 55X				

This area intentionally blank



6 SYSTEM CONFIGURATION AND CHECKOUT PROCEDURES

6.1 Overview

This section contains instructions for configuration and checkout of the G5 Electronic Flight Instrument, GMU11, and GAD 29/29B. The steps which are not applicable to a particular installation may be skipped. A summary of the steps required for checkout of the G5 is as follows:

- Perform mounting, wiring, and power checks (see section 6.2)
- Configure the G5 (see Section 6.3)
- Perform post-installation checkout procedures (see Section 6.3)
- Perform documentation checks (see section 6.4)



NOTE

Throughout the next sections, many screenshots and examples are used to illustrate the software loading and configuration and checkout process. Changes may occur which result in the examples being out of date.

6.2 Mounting, Wiring, and Power Checks

Verify all wire harnesses are properly secured and shields are connected to the shield blocks of the connectors. Check the movement of the flight and engine controls to verify there is no interference. Prior to powering up the G5 and supporting equipment, the wire harnesses must be checked for proper connections to the aircraft systems and other avionics equipment. Point to point continuity must be checked on all wiring to expose any faults such as shorting to ground. Any faults or discrepancies must be corrected before proceeding.

After accomplishing a continuity check, perform power and ground checks. Remove power from the aircraft upon completion of the wire harness checkout.

The G5 and supporting equipment can be installed after completion of the continuity and power checks.

6.3 Post-Installation Checkout Procedures

The following procedures will verify the proper operation of the G5 and its intended function as an attitude indicator or DG/HSI. The G5 can be installed in several different configurations that affect the following testing. If a section of testing is not supported by the installed configuration disregard that testing. It is assumed that the person performing these checks is familiar with the aircraft, has a working knowledge of typical avionics systems, and has experience using the test equipment defined in this section.



NOTE

For G5 operational instructions, see 190-01112-12, Pilot's Guide, Garmin G5 Electronic Flight Instrument, Part 23 AML STC.



NOTE

Some procedures in this section require that the GPS receiver is receiving sufficient satellite signal to compute a present position. This requires outdoor line-of-site to GPS satellite signals or a GPS indoor repeater.



NOTE

As these procedures involve engine run-up and moving the aircraft, it is recommended that the installer read this entire section before beginning the checkout procedure.



NOTE

All test equipment should have current calibration records.

6.3.1 Recommended Test Equipment

The following test equipment is recommended to conduct and complete all post installation checkout procedures in this section:

- Pitot/static ramp tester
- Digital Multi-Meter (DMM)
- Ground power unit capable of supplying 14/28 Vdc power to the aircraft systems and avionics
- Outdoor line-of-sight to GPS satellite signals or GPS indoor repeater
- Digital Level or equivalent
- VHF NAV Test Set

6.3.2 Configuration Mode

All of the configuration and calibration procedures in this section are performed in configuration mode. To enter configuration mode, hold down the knob while powering on the G5. Configuration selections are made by rotating and pressing the knob on the face of the G5 as necessary to select the correct configurations.

6.3.3 Software Loader Card Creation

The software image is an executable self-extracting file which builds the correct file structure onto a microSD card for use loading software to all installed G5's. To obtain the current software image is an executable self-extracting file follow the procedures outlined below.



NOTE

If the G5 units report the same software P/N and versions as indicated on the Aviation Product/General Aviation/Indicators/G5 page, it is not required to complete this section.

1. To obtain the latest software version approved for this STC, visit www.Garmin.com and navigate to the Aviation Product/General Aviation/Indicators/G5 page. Do not download software from the Experimental Aircraft web page.



2. Download the self-extracting update file onto your hard drive.
3. Insert a FAT32-formatted micro SD card with at least 20 MB of free space into your card reader.
4. Open the self-extracting update file and follow the instructions provided by the installer application. You will be prompted to specify the drive letter of the SD card you wish to use for the update. When the transfer is complete, safely eject the SD card.

6.3.4 Initial Power On

1. Apply power to the G5 unit(s).
2. On the G5 attitude indicator, verify the attitude is displayed and there are no invalid parameters (no red-X shown).
3. On the G5 HSI/DG , verify heading information is displayed and there are no invalid parameters (no red-X shown).



NOTE

On power-up, “Magnetometer not calibrated.” may be displayed on the G5 #1 if a GMU11 is installed. This will cause the compass card on the HSI/DG to display GPS track if installed as an HSI and nothing if installed as a DG. Magnetometer calibration is completed later in section 6.3.7.4.

4. Continue to Section 6.3.5.

6.3.5 SOFTWARE LOADING PROCEDURE

G5 software loading can be performed in either normal or configuration mode.



NOTE

If the G5 unit reports the same software P/N and version as indicated on the Aviation Product/General Aviation/Indicators/G5 page, it is not required to complete this section.



NOTE

If two G5’s are installed, this procedure must be completed on both G5’s and can be done concurrently. If both G5 units software do not match the G5 will post a “Software Version Mismatch” message on the display. This message will be removed when both units have been loaded with matching software.

1. Power on the G5, then insert a properly formatted microSD™ card into the microSD™ card slot.



NOTE

It is also acceptable to insert the microSD™ card before powering on the unit.

2. A software update pop-up will appear on the screen. Select OK to begin the update.



NOTE

The software update pop-up will only be displayed if the version of software to be loaded is newer than the version currently on the unit.



3. The unit will reboot to the software update screen and the software update will begin automatically. This screen will show the progress of the software update.
4. Ensure power is not removed while the update is being performed.
5. The unit will reboot after the update is complete.
6. The new software version will be displayed while the unit powers on or in the configuration mode menu.

6.3.6 CONFIGURATION PAGES

6.3.6.1 Configuration Pages Summary

When in configuration mode the G5 displays the following configurations pages:

- Device Information – used to display LRU (device) specific information such as the software version and basic indicator configuration.
- Attitude – used to configure Indicator Type, Pitch Display preferences, and User Pitch offset.
- Air Data – used to enable/ disable the G5 Air Data Sensors and configure the Vertical Speed rate.
- Airspeed – allows for configuration of the reference speeds.
- Magnetometer – allows configuration of magnetometer and magnetometer positioning.
- Flight Controls – used to configure the system for autopilot servos if installed.
- Backlight – used to configure backlight configuration parameters.
- Display – used to configure the display format of the G5.
- Battery – used to set backup battery status and power off modes.
- GPS – used to configure the internal GPS receiver.
- Navigation – used to configure the display of navigation information.
- Units – This page is used to configure the units type to display altitude, airspeed, ground speed, vertical speed and pressure displays.
- RS-232 – used to configure the RS-232 input and output ports used of the G5.
- ARINC 429 - used to configure the ARINC 429 input and output ports used of the G5.
- Exit Configuration Mode – used to exit configuration mode.

6.3.6.2 G5 configuration

Reference Section 5 to select the corresponding equipment configuration that is installed in the aircraft. The configuration settings are provided in the appropriate section for each installation possibility. See Section 6.4.1 for information about recording the configuration settings to keep in the aircraft records for future reference.

- G5 (Attitude Indicator) with External GPS Antenna – Section 5.3
- G5 (Attitude Indicator) with GPS Position Input (RS-232) – Section 5.4
- G5 (Attitude Indicator) and GMU11 with GPS Position Input (RS-232) – Section 5.5
- G5 (Attitude Indicator or DG), GMU 11 and GPS Antenna – Section 5.6
- G5 (HSI) with VHF Navigator Section - 5.7
- G5 (HSI) with GPS/VHF Navigator Section - 5.8
- Dual G5 without Navigator Section - 5.9



- Dual G5 with VHF Navigator - 5.10
- Dual G5 with GPS/VHF Navigator Section - 5.11
- G5 Interface to Third Party Autopilots Section - 5.12

6.3.7 G5 POST-INSTALLATION CALIBRATION PROCEDURES

After mechanical and electrical installation of the G5 has been completed, prior to operation, a set of post-installation calibration procedures must be carried out. Table 6-1 describes the required and optional calibration procedures.

Table 6-1: Post-Installation Calibration Procedure Summary

Calibration Procedure	Procedure Name	Procedure Description	Installations Requiring Procedure
A	Pitch/Roll Offset Compensation	Level aircraft	Procedure A is required for all installations
B	Engine Run-Up Vibration Test	Validate vibration characteristics of installation	Procedure B is required for all installations
C	Air Data Static Pressure Calibration	Altitude Calibration	Procedure C is only required if Section 6.3.8.2 results for the G5 fall outside the tolerances of the Part 43 Appendix E tests.
D	GMU 11 Magnetometer Calibration	Magnetometer Calibration	Procedure D is only required if a GMU 11 was installed

This area intentionally blank



6.3.7.1 CALIBRATION PROCEDURE A: PITCH/ROLL OFFSET COMPENSATION



NOTE

The G5(s) must be installed within the tolerances shown in Figure 4-4 and Figure 4-5.



NOTE

If two G5's are installed, this procedure must be done on both and can be done concurrently.

See Section 6.3.7.1.1 for example of this calibration procedure.

Using the following procedure, complete these equations.

New Pitch Offset (From Step 9)	-	A/C Pitch Offset (From Step 2)	=	Pitch Calibration (For Step 10)
<input type="text"/>		<input type="text"/>		<input type="text"/>
New Roll Offset (From Step 9)	-	A/C Roll Offset (From Step 2)	=	Roll Calibration (For Step 10)
<input type="text"/>		<input type="text"/>		<input type="text"/>

1. *Consult the aircraft's maintenance manual and locate the longitudinal (ROLL) and lateral (PITCH) leveling points.
2. Using a digital level, document the Aircraft Roll and Pitch offsets from these leveling points as the aircraft sits on the landing gear. (Do not enter, exit, or move the aircraft at this point.) Use a negative number for left wing up or nose up readings. Use a positive number for left wing down or nose down readings.
3. Select the Attitude Configuration Page.
4. Select Calibrate Pitch/Roll.
5. Ensure that aircraft and the unit comply with all on-screen instructions then select Start.
-Disregard item 1, leveling the aircraft is not necessary.
6. A progress screen will then be displayed. There is a 30 second countdown timer for the procedure that resets if the aircraft moves.
7. When the calibration is complete, a successful status message will be displayed along with the new pitch and roll offsets.
8. If the leveling offsets documented from Step 2 were both 0.0, the calibration is complete. If either new offset were other than 0.0, continue to step 9.
9. Document the "New Roll Offset" and "New Pitch Offset" numbers and complete the equation.
10. Press "Done" and adjust the values of the "Roll Calibration" and the "Pitch Calibration" values to the answers from the equations.
11. Exit Configuration Mode.
12. This completes the Attitude Calibration Procedure.

*In flight level cruse attitude is not necessarily the same as the leveling points provided by the manufacturer. Adjustments to the pitch and roll offsets can be made to compensate for the aircraft flight characteristics.

6.3.7.1.1 Attitude Calibration Example

In the Figure 6-1, the aircraft is sitting 5.2° nose up and 1.4° left wing up, (both negative number). Also, the G5 is mounted in the pilot's panel, which has an 8° forward tilt. After completing the Calibration Procedure in Step 7, the value in the Pitch Calibration field on the G5 is 2.8° and -1.4° in the Roll Calibration field. See Figure 6-2 for the completed equations.

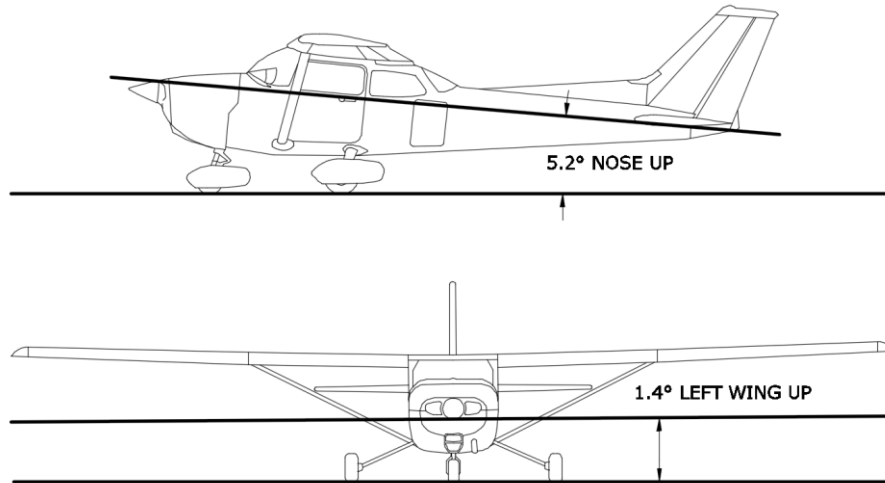

Figure 6-1, Attitude Calibration Example

New Pitch Offset (From Step 9)	-	A/C Pitch Offset (From Step 2)	=	Pitch Calibration (For Step 10)
2.8		-5.2		8.0
New Roll Offset (From Step 9)	-	A/C Roll Offset (From Step 2)	=	Roll Calibration (For Step 10)
-1.4		-1.4		0.0

Figure 6-2, Example of Calibration Equations

This area intentionally blank

6.3.7.2 CALIBRATION PROCEDURE B: ENGINE RUN-UP VIBRATION TEST



NOTE

Calibration Procedure B is required for all installations to validate the vibration characteristics of the installation.



NOTE

This section of the Calibration Procedure can be run in conjunction with the compass rose swing (Section 0).



NOTE

If two G5's are installed, this procedure must be done on both and can be done concurrently.

Conduct the Engine Run-Up Vibration Test. The test is intended to help discover mounting issues and does not account for all possible vibration profiles that may be encountered during normal aircraft operation.

1. Select the Attitude configuration page.
2. Select Vibration Test.
3. Ensure the aircraft complies with all on-screen instructions, then select Start.
4. Gradually increase engine power from idle to full power and back to idle in 1-2 minutes. A screen will be displayed showing the test in progress.
5. After the gradual increase and decrease in aircraft power verify for passing or failing results.
 - a. If the green check mark remains during the engine power sequence, this indicates Passing results, select Done. This checkout is complete.
 - i. Exit configuration mode.
 - b. Failing results will be indicated by a red "X" as shown in Figure 6-3 below. Select Done when the test has been completed and follow the instructions in Step 6 below.

This area intentionally blank



Figure 6-3 Engine Vibration Test Failure Indication

6. If failures are indicated, repeat the test. If failures persist, the installation is unreliable until the source of the vibration problem is identified and remedied. Record the out of range limit values for future reference.

The following are potential causes for failures of the engine run-up test:

- a. Excessive flexing of the G5 mechanical mounting with respect to airframe
- b. Vibration or motion of the G5 caused by neighboring equipment and/or supports.
- c. Mounting of the G5 in a location that is subject to severe vibrations (e.g. close to an engine mount).
- d. Instrument panel shock mounts worn, broken, or permit excessive movement.
- e. Mounting screws and other hardware for G5 not firmly attached.
- f. G5 connector not firmly attached to unit.
- g. Cabling leading to the G5 not firmly secured to a supporting structure.
- h. An engine/propeller combination that is significantly out of balance.



NOTE

In some aircraft, attempting the engine run-up test on a day with very strong and/or gusty winds may cause the test to occasionally fail. However, a failure during windy conditions cannot not be taken as evidence that the test would pass in calm conditions; an actual pass is required before the installation can be considered adequate.

6.3.7.3 CALIBRATION PROCEDURE C: AIR DATA STATIC PRESSURE CALIBRATION



NOTE

Procedure C is only required if Section 6.3.8.2 results for the G5 fall outside the tolerances of the Part 43 Appendix E tests.



NOTE

If two G5's are installed, this procedure must be done on both and can be done concurrently.



The Air Data configuration page has a selection for static pressure calibration. This procedure is used to perform an altimeter calibration.

The static pressure calibration requires the use of a pressure control system (test set) with an altitude accuracy of at least ± 5 ft. at sea level and ± 20 ft. at 30,000 ft. It is necessary to re-calibrate to sea level (0 ft.), 10,000 ft., 20,000 ft., and optionally to 30,000 ft. The operator is allowed to finish the calibration at the end of the 20,000 ft. calibration if the aircraft operational ceiling is below 20,000 ft.



CAUTION

To avoid damaging the G5 pressure sensors, both the pitot and static ports must be connected to the test set.

1. Prior to running the calibration procedure below perform a static system leak check in accordance with 14 CFR Part 43 Appendix E.
2. Select the Air Data configuration page.
3. Select Calibrate Static Pressure.
4. Ensure all on-screen instructions have been complied with, then press Start.
5. At each calibration point the display will present a screen indicating the pressure altitude to set. Once the altitude is set, select Ready to calibrate this pressure.
6. During the calibration at each pressure, the pressure must be held constant for 30 seconds for the calibration step to be successful. The calibration may be cancelled at any point should the test setup require adjustment before repeating. A progress screen will be displayed showing the status of the test.
7. Select Done when the static pressure calibration is successfully completed.
8. Exit configuration mode.

6.3.7.4 CALIBRATION PROCEDURE D: GMU 11 Magnetometer Calibration



NOTE

All selections made in configuration mode in this section are made on the G5 ID strapped as #1. Refer to APPENDIX A for details on ID strapping.



CAUTION

This magnetometer calibration procedure should be carried out on a compass rose to guarantee measurements free of environmental magnetic disturbances. If a compass rose is not available a sight compass can be used. Attempting to carry out this procedure on a typical ramp area may not yield a successful calibration. The accuracy of the heading display on the G5 cannot be guaranteed if this calibration is not performed on a magnetically clean and level surface.

**NOTE**

The calibration procedure in Section 0 must be completed prior to performing this procedure.

**NOTE**

A magnetometer calibration failure is indicated by a “Magnetometer not Calibrated” message on the G5 on power up. In the event of a failure, verify that the installation passes the magnetometer interference test in Section 6.3.8.3. If necessary, move the aircraft to a different location and attempt the magnetic calibration again.

1. Start the aircraft engine in accordance with the aircraft AFM or POH.
2. After aircraft engine startup, taxi the aircraft to a properly calibrated compass rose.
3. At the compass rose, align the aircraft to a heading of magnetic north (+/- 10°).
4. Restart the G5 in configuration mode.
5. If the G5 installation being calibrated does not utilize a GPS input, go to the “GPS” page group and “Enable” the Internal GPS Receiver.
6. Go to the “Magnetometer” page Group on the G5 unit.
7. Select the “Calibrate Magnetometer...” page.
8. The G5 will display instructions. Follow the on-screen instructions and select “Next” to cycle through each page of instructions.
9. On the final page, select “Start” to begin the calibration.
10. The G5 display advises the operator when to turn the aircraft, when to stop, and when to turn again.
11. Upon instruction to turn, taxi the aircraft in a right turn. After approximately 25° to 30° of turn from the last heading, the G5 display advises the operator when to stop the aircraft.

**NOTE**

If smooth accurate turns are not made, the G5 may incorrectly interpret a station and instruct to “Hold current position...” prior to or after completion of the heading change. If this scenario is encountered, it is best for the operator to temporarily ignore the “Hold current position...” command and instead use compass rose references to complete the heading change. Dwelling at these 30° increments for the time recommended by the G5 should result in successful calibration.

12. The G5 instructs the operator to dwell at multiple headings around a complete circle.
13. Repeat the turn-and-stop process until the G5 advises that a successful calibration is complete and “Calibration: Success” is displayed on the G5.
14. Select “Done” on the G5 to conclude this procedure
15. If the Internal GPS receiver was “Enabled” above for G5 installations that do not utilize a GPS input “Disable” the Internal GPS receiver before exiting configuration mode.
16. Exit configuration mode.



6.3.7.4.1 Compass Swing

After the Magnetic Calibration Procedure is completed, a compass swing must be performed to verify the GMU 11 heading accuracy. If each heading displayed on the G5 (or G5 #1 and G5 #2) is within $\pm 10^\circ$ of the actual heading no further adjustments are necessary.

1. With the G5 (or G5 #1 and G5 #2 for a dual G5 installation) in normal mode, all of the aircraft and avionics systems powered and operating normally, position the aircraft on a known compass rose at a heading 360° (North), or select a level and magnetically clean location and use a sight compass to position the aircraft to a heading of 360° (North).
2. Record the heading displayed on the G5 (or G5 #1 and G5 #2 for a dual G5 installation) in Table 6-2. Also record the heading displayed on the standby compass (these values can be used to complete the standby compass calibration card).
3. Repeat step 2 for each of the headings listed in Table 6-2.
4. Calculate the heading errors by subtracting the displayed (B) value from the actual (A) value for each of the headings in Table 6-2.

Table 6-2: Heading Verification

Heading (A)	Displayed G5 Heading (B)	Heading Error (A-B)	Stby Compass Heading
360° (North)			
30°			
60°			
90° (East)			
120°			
150°			
180° (South)			
210°			
240°			
270° (West)			
300°			
330°			

5. If all calculated heading errors for the G5 are $\pm 10^\circ$ from the surveyed heading, the installation is acceptable and no further work is required to correct the GMU 11 installation. Proceed to section 6.3.8.3.
6. If a Heading Error (A-B) is greater than $\pm 10^\circ$, calculate the average error by adding all errors and dividing by 12. This is the angle by which the GMU 11 must be physically rotated to correct the installation.
7. Modify the installation to rotate the GMU 11 by the amount calculated in the previous step. When looking down at the GMU 11, rotate clockwise for positive values, and counterclockwise for negative values.
8. After physically correcting the GMU 11 installation, repeat the procedures in Section 6.3.7.4 and this section.

6.3.8 G5 Post Installation Checks

6.3.8.1 Pitot Static System Leak Check

Perform a pitot static system leak check in accordance with the aircraft manufacturer's approved data.



CAUTION

To avoid damaging the G5 pressure sensors, both the pitot and static ports must be connected to the air data test set.

6.3.8.2 Altimeter System Check

For aircraft that are IFR certified, perform an altimeter system test of the G5 in accordance with 14 CFR Part 43 Appendix E.

6.3.8.3 Magnetometer Interference Check

With the G5 in configuration mode, initiate the magnetometer interference test procedure by performing the following steps:



NOTE

All selections made in configuration mode in this section are made on the G5 ID strapped as #1. Refer to APPENDIX A for details on ID strapping.

NOTE

All selections made in configuration mode in this section are made on the G5 ID strapped as #1. Refer to APPENDIX A for details on ID strapping.

1. Select the "Magnetometer" page group on the G5 #1
2. Select the "Interference Test..." page.
3. Follow the instructions on each page displayed on the G5. Select "Next" to cycle through the pages and "Back" to go to the previous page.



NOTE

The last page instructs the operator to prepare a detailed test sequence list with precise start and stop times for exercising all electronic devices. Only the electronic devices that are likely to affect the operation of the GMU 11 magnetometer need be included in the test sequence. The list of relevant electronic devices varies from aircraft to aircraft. This sequence is the same sequence developed for the magnetometer interference survey in APPENDIX C.

4. Select "Start" to begin the test procedure.
5. The operator should carry out the actions called for in the prepared test sequence.



NOTE

It is important that all actions are carried out in the order and at the precise elapsed time as specified in the prepared test sequence.

6. After the “Begin test sequence” appears, wait approximately five seconds and perform each of the actions listed in the test sequence table. Refer to Section C.3 for an example of a test sequence.
7. When the test sequence is completed, wait approximately five seconds and then select “Done” to complete the test.

The G5 informs the operator if the installation has passed or failed the magnetometer interference test. The results displayed indicate the worst case percentage of limit and the time at which it occurred. If the test passes, no further action is required.

If the test fails, the installation should be considered unreliable until the source of magnetic interference is identified and remedied. The magnetometer interference test must be repeated until passed. When the magnetometer interference test fails, record the magnetometer maximum deviation value and its corresponding timestamp. Compare the corresponding timestamp with the prepared test sequence to identify which action produced the problem.

Two common reasons for a failed magnetometer interference test are:

1. New equipment is installed in close proximity to the GMU 11 magnetometer.
2. An existing or new electronic device has become grounded through the aircraft structure instead of via the proper ground wire in a twisted shielded pair, especially if the ground return path through the aircraft structure passes near the GMU 11.

6.3.8.4 Initial Power On Checks

1. Apply power to the aircraft and aircraft systems and allow the aircraft systems to initialize.
2. On the G5 Attitude display, verify the following:
 - No red-X’s displayed
 - Attitude display
 - Heading display (if interfaced to a GMU 11) Ground Track display (if not interfaced to a GMU 11)
 - Airspeed Tape (Digital read out will be dashes)
 - Altitude Tape (Digital readout should be reasonable to field elevation)
 - Ground speed field
 - Slip skid display
 - Current track bug
 - Barometric Pressure setting field
3. On the G5 HSI display, verify the following:
 - No red-X’s displayed
 - Heading/ Ground Track display
 - Heading Display - if interfaced to a GMU 11, indicated by white numbers indicating magnetic heading.



- Ground Track display (if not interfaced to a GMU 11, indicated by magenta numbers indicating GPS ground track).
- Ground speed field (configurations without a GPS input will not display Ground Speed)
- Current track bug
- Rotating compass rose.

6.3.8.5 GPS Position Check (Installations using an External Antenna interfaced to the G5)

This test must be conducted outside, as the use of a GPS repeater inside a hangar may result in a failed test.

1. Apply power to the aircraft and aircraft systems and allow the aircraft systems to initialize and the G5(s) to acquire sufficient satellites for a GPS solution.
2. Enter configuration mode on the G5 Attitude indicator and the G5 HSI if the optional GPS antenna is interfaced, and navigate to the GPS Configuration Page.
3. Ensure a valid GPS position fix is obtained by monitoring the GPS status. The following status indications are valid fixes for this test.
 - 3D GPS
 - 3D DIFFERENTIAL

6.3.8.6 GPS Position Check (Installations using a GPS Navigator interfaced to the G5)

This test must be conducted outside, as the use of a GPS repeater inside a hangar may result in a failed test.

1. Apply power to the aircraft and aircraft systems and allow the aircraft systems to initialize and the GPS Navigator to acquire sufficient satellites for a GPS solution.
2. On the G5 Attitude display, verify the following;
 - Ground Track display (if not interfaced to a GMU 11)
 - Ground speed field
3. On the G5 HSI display, verify the following;
 - Ground Track display (if not interfaced to a GMU 11, indicated by magenta numbers indicating GPS ground track).
 - Ground speed field
 - Current track bug

This area intentionally blank



6.3.8.7 VOR/LOC/GS Check

This test is only performed for installations that have an HSI installed and interfaced to a VHF navigation source.

Check the VOR, ILS, and Glideslope functions with ramp test equipment. Operate the equipment according to the test equipment manufacturer's instructions. Adjust the RF signal to a level adequate to perform the test. Select the appropriate HSI source as required by the VHF navigation source interfaced to the G5 HSI.



NOTE

The HSI does not show a course deviation bar unless a valid VHF navigation frequency is tuned.

6.3.8.7.1 VOR

1. Apply power to the aircraft and aircraft systems and allow the aircraft systems to initialize.
2. Tune the VHF NAV to the NAV/COM Test Set frequency for VOR operation.
3. On the G5 HSI set the CDI course to 360 degrees.
4. On the NAV ramp tester simulate a centered VOR needle presentation.
5. Verify the G5 HSI CDI displays a centered deviation bar for VOR.
6. On the NAV ramp tester simulate 355 degrees.
7. Verify the G5 CDI deviation bar is one dot left.
8. On the NAV ramp tester simulate 350 degrees.
9. Verify the CDI deviation bar is two dots left.
10. On the NAV ramp tester simulate 340 degrees.
11. Verify the G5 HSI CDI deviation bar is full scale to the left.
12. On NAV ramp tester simulate 005 degrees.
13. Verify the G5 HSI CDI deviation bar is one dot right.
14. On the NAV ramp tester simulate 010 degrees.
15. Verify the G5 HSI CDI deviation bar is two dots right.
16. On the NAV ramp tester simulate 020 degrees.
17. Verify the G5 HSI CDI deviation bar is full scale to the right.



6.3.8.7.2 LOC/GS

1. Tune the VHF NAV to the NAV/COM Test Set frequency for LOC/GS operation.
2. On the NAV ramp tester simulate centered LOC and GS needles presentation.
3. Verify the G5 HSI CDI displays centered deviation for both LOC and GS.
4. On the NAV ramp tester simulate one dot left for LOC and one dot down for GS.
5. Verify G5 HSI CDI deviation bar is one dot left and the GS vertical deviation indicates one dot down.
6. On the NAV ramp tester simulate two dots left for LOC and two dots down for GS.
7. Verify G5 HSI CDI displays two dots left and the GS vertical deviation indicates two dots down.
8. On the NAV ramp tester simulate full scale left for LOC and full scale down for GS.
9. Verify G5 HSI CDI deviation bar is full scale left and the GS vertical deviation indicates full scale down.
10. On the NAV ramp tester simulate one dot right for LOC and one dot up for GS.
11. Verify G5 HSI CDI deviation bar is one dot right and the GS vertical deviation indicates one dot up.
12. On the NAV ramp tester simulate two dots right for LOC and two dots up for GS.
13. Verify G5 HSI CDI displays two dots right and the GS vertical deviation indicates two dots up.
14. On the NAV ramp tester simulate full scale right for LOC and full scale up for GS.
15. Verify G5 HSI CDI deviation bar is full scale right and the GS vertical deviation indicates full scale up.

6.3.8.8 GPS Navigation Interface Check

This test is only performed for installations that have an HSI installed and interfaced to a GPS navigation source.

Conduct this test with the aircraft positioned where it can receive GPS signal.

1. Apply power to the aircraft and aircraft systems and allow the aircraft systems to initialize and the GPS navigator to acquire sufficient satellites for the GPS solution 3D Diff Nav.
2. Enter a simple flight plan that contains a GPS LPV approach and activate the approach.
3. On the G5 Attitude indicator, verify the following:
 - a lateral deviation indicator is displayed directly above the slip skid indicator and a deviation pointer magenta in color.
 - A vertical deviation indicator to the right of the aircraft symbol.
4. On the G5 HSI verify the following:
 - A vertical deviation indicator to the right of the rotating compass rose.
 - GPS LPV displayed in magenta located in the top center of the rotating compass rose.



- A lateral deviation indicator displayed in magenta.
- A to/From indicator displayed in magenta.
- A cyan bearing pointer. (Bearing Pointer may need to be activated on the HSI Menu)

6.3.8.9 GPS Receiver COM Interference Check

This test must be conducted outside, as the use of a GPS repeater inside a hangar may result in a failed test.

1. Apply power to the aircraft and aircraft systems and allow the aircraft systems to initialize and the G5(s) or GPS navigator (if installed) to acquire sufficient satellites for a GPS solution.



NOTE

For G5's interfaced to a GPS navigator for position source access to the G5(s) configuration page is not necessary. Monitoring the G5 Attitude and/or G5 HSI for a loss of GPS information or amber LOI on the HSI is sufficient.

For G5's interfaced to an external GPS antenna:

2. Enter configuration mode on the G5 Attitude indicator and the G5 HSI if the optional GPS antenna is interfaced, and navigate to the GPS Configuration Page.
3. Ensure a valid GPS position fix is obtained by monitoring the GPS status. The following status indications are valid fixes for this test.
 - 3D GPS
 - 3D DIFFERENTIAL
4. Select 121.150 MHz on the COM transceiver.
5. Transmit for a period of 30 seconds while monitoring the GPS status.
6. During the transmit period,
 - On G5(s) with a direct GPS antenna connected, verify that the GPS status does not lose a valid GPS position fix.
 - On G5(s) interfaced to a GPS navigator for position source monitor the G5 Attitude indicator and/or G5 HSI for a loss of GPS information (ground speed information) or amber LOI on the HSI.
7. Repeat steps 2 through 4 for the following frequencies:
 - 121.175 MHz
 - 121.200 MHz
 - 131.250 MHz
 - 131.275 MHz
 - 131.300 MHz



8. Repeat steps 2 through 5 for all other installed COM transceivers (if applicable).
9. If an installed COM supports 8.33 MHz channel spacing, increase the transmit period to 35 seconds and repeat steps 3 through 5 for the following frequencies:
 - 121.185 MHz
 - 121.190 MHz
 - 130.285 MHz
 - 131.290 MHz
10. Repeat step 7 for all other installed COM transceivers supporting 8.33 MHz channel spacing (if applicable).

6.3.9 Electromagnetic Compatibility (EMC) Check

An EMC check must be conducted once the G5(s) and supporting equipment is installed and all interfaces to external equipment are verified to be correctly working. The EMC check makes sure the equipment is not producing unacceptable interference to the other avionics systems, and other avionics systems are not producing unacceptable interference to the G5.

An example EMC Source/Victim matrix is shown in Figure 6-4.

1. Enter equipment installed in the aircraft into the Source row and Victim column of the fillable form.
2. Apply power to all avionics systems except the equipment installed under this STC.
3. Make sure all existing avionics systems are properly functioning.
4. Apply power to the G5.
5. Remove power from all other avionics systems.
6. Apply power and/or operate the systems listed on the fillable form, one system at a time. Make sure to pull/push circuit breakers or turn on/off large loads, e.g. heaters, cycling flaps (if electrical) etc.
7. Make sure the G5 properly functions.
 - a. When the VHF COM is operating as a source, transmit on low/med/high unused frequencies.
8. Make sure each radio properly functions.
 - a. For each VHF COM radio, monitor one local frequency, one remote (far field) frequency, and one unused frequency.
 - b. Make sure there are no unintended squelch breaks or audio tones interfere with communications.
 - c. For each VHF NAV radio, monitor one local frequency, one remote (far field) frequency, and one unused frequency.
 - d. Make sure there are no guidance errors.
 - e. Make sure there are no audio tones that interfere with the station ID.
 - f. For each GPS Navigator, enter a simple flight plan and display as appropriate. i.e. Navigator Display, G5, HSI, CDI etc., if installed.
 - g. Make sure there are no guidance errors.
9. Make sure all other avionics properly function.

		VICTIM																														
		G5 #1	G5 #2 (If installed)	GMU 11 (If installed)	GAD 29/29B (If installed)	Magnetic Compass	Clock	OAT Indicator	Power Plant Instruments	Autopilot / SAS	Navigation Radio(s)	Communication Radio(s)	Engine Relight	Fuel Valve	Pitot Heat	Pulse Light	Generator	Pos Lt	Anti Coll Lt	Ldg Lts	Gov RPM Incr / Decr	Eng Deicing	Hyd System	Radar Altimeter	TAS/TCAS	Transponder	Audio Panel	GTX 3X5	<add equipment here>	<add equipment here>		
SOURCE	G5 #1																															
	G5 #2 (If installed)																															
	GMU 11 (If installed)																															
	GAD 29/29B (If installed)																															
	Magnetic Compass																															
	Clock																															
	OAT Indicator																															
	Power Plant Instruments																															
	Autopilot / SAS																															
	Navigation Radio(s)																															
	Communication Radio(s)																															
	Engine Relight																															
	Fuel Valve																															
	Pitot Heat																															
	Pulse Light																															
	Generator																															
	Pos Lt																															
	Anti Coll Lt																															
	Ldg Lts																															
	Gov RPM Incr / Decr																															
	Eng Deicing																															
	Hyd System																															
	Radar Altimeter																															
	TAS/TCAS																															
	Transponder																															
	Audio Panel																															
	GTX 3X5																															
	<add equipment here>																															
	<add equipment here>																															

Figure 6-4 Example EMC Source/Victim Matrix

6.3.10 Vacuum System Pressure Setting

If a vacuum instrument was removed by the installation of the G5 Electronic Flight Instrument and there are other instruments using the vacuum system, follow the aircraft manufacturers procedure to set instrument vacuum system pressure.

6.3.11 Third Party Autopilot Interface Tests

The G5 System can interface with various autopilots. Before proceeding with the autopilot interface tests, verify that the G5 has been configured for the installed autopilot, if applicable, as defined in Section 5.12. Only those interfaces which are directly affected by the G5 AML STC are covered by this manual; if any other autopilot modifications were performed they are outside the scope of this STC and must be checked in accordance with the autopilot installation manual.



WARNING

It is important that the G5 System be properly configured in order to prevent signals from the G5 System from damaging the autopilot computer. Refer to section 5.12.



NOTE

The following procedures are general in nature and it may be necessary to reference the autopilot manufacturers testing instructions to allow the autopilot to be tested properly.

6.3.11.1 Heading and Course Error Tests

6.3.11.1.1 Heading

1. Apply power to the aircraft and aircraft systems and allow the aircraft systems to initialize.
2. On the G5 HSI, set the heading bug to the current aircraft heading.
3. Engage the autopilot in heading mode.
4. Adjust the heading bug to the left of the aircraft heading.
5. Verify that the flight controls move toward the left.
6. On the G5 HSI, adjust the heading bug to the right of the aircraft heading.
7. Verify the flight controls move toward the right.
8. Center the heading bug at the aircraft heading.
9. Disengage the autopilot.



6.3.11.1.2 VOR Course

1. Apply power to the aircraft and aircraft systems and allow the aircraft systems to initialize.
2. Tune the VHF NAV to the NAV/COM Test Set frequency for VOR operation.
3. Set the Course pointer on the G5 HSI 15 degrees to the left of aircraft heading and ensure that the G5 HSI CDI is displaying VOR navigation information.
4. Simulate a VOR signal with a “TO” course equal to the aircraft heading.
5. Slowly adjust the course pointer on the G5 HSI CDI toward the aircraft heading until VOR captures.
6. Center G5 HSI CDI course pointer on the aircraft heading.
7. Engage the autopilot in NAV mode.
8. Adjust the NAV ramp tester course and the G5 HSI CDI course pointer 20 degrees to the left of current aircraft heading.
9. Verify that the flight controls move toward the left.
10. Adjust NAV ramp tester course to aircraft heading.
11. Adjust the NAV ramp tester course and the G5 HSI CDI course pointer 20 degrees to the right of current aircraft heading.
12. Verify that the flight controls move toward the right.
13. Adjust the NAV ramp tester course to aircraft heading.
14. Disengage the autopilot.

6.3.11.1.3 LOC

1. Tune the VHF NAV to the NAV/COM Test Set frequency for LOC operation.
2. On the NAV ramp tester simulate centered LOC needle presentation.
3. Set the Course pointer on the G5 HSI to the current aircraft heading.
4. Verify the G5 HSI CDI displays centered deviation for LOC.
5. On the NAV ramp tester simulate 0.093 DDM Left LOC.
6. Verify G5 HSI CDI deviation bar is one dot left.
7. Verify that the flight controls turn to the left.
8. On the NAV ramp tester simulate 0.093 DDM Right LOC.
9. Verify G5 HSI CDI displays one dot right.
10. Verify that the flight controls turn to the right.
11. On the NAV ramp tester simulate centered LOC needle presentation.
12. Disengage the autopilot.

6.3.11.1.4 GPSS Course

This test is only performed for installations that are interfaced to a GPS navigation source and the interfaced autopilot did not previously have a GPSS function. Conduct this test with the aircraft positioned where it can receive GPS signal.

1. On the GPS navigator, enter a simple Direct-To flight plan with a waypoint that is on the current aircraft heading and select the G5 HSI CDI to display GPS. If the navigator has the capability to enter user waypoints, a user waypoint can be entered to facilitate this test. It is suggested that the waypoint be within 5 miles of the current aircraft position for best results.
2. On the G5 Attitude display, press the multifunction knob to display the G5 attitude menu, highlight GPSS and press the multifunction knob to select GPSS.



3. Verify the following;
 - On the G5 Attitude (if Installed)
 - GPSS field in the menu has a green bar at the bottom indicating GPSS is selected.
 - The heading bug is a hollow cyan bug.
 - An advisory display is presented in the upper left hand corner that shows a normal heading bug crossed by a white X and GPSS in white next to the bug.
 - On the G5 HSI
 - GPSS field in the menu has a green bar at the bottom indicating GPSS is selected.
 - The heading bug is a hollow cyan bug.
 - An advisory display is presented in the upper left hand corner that shows a normal heading bug crossed by a white X and GPSS in white next to the bug.
4. On the navigator select OBS to enter GPS OBS mode.
5. Set the OBS course for the current aircraft heading. (it is assumed the waypoint is on the current aircraft heading)
6. Engage the autopilot in HDG mode.
7. Adjust the OBS course 20 degrees to the left of current aircraft heading.
8. Verify that the flight controls move toward the left.
9. Adjust the OBS course 20 degrees to the right of current aircraft heading.
10. Verify that the flight controls move toward the right.
11. Adjust the OBS course to aircraft heading.
12. Disengage the autopilot.

6.4 Documentation Checks

6.4.1 Instructions for Continued Airworthiness (ICA)

Ensure the appropriate aircraft information is recorded in *Garmin G5 Electronic Flight Instrument Part 23 AML STC Maintenance Manual including Instructions for Continued Airworthiness*, P/N 190-01112-11, Appendix A, Appendix B and Appendix C and is retained with the aircraft permanent records.

Insert the completed Appendices of the STC MM/ICA into the aircraft permanent records.

6.4.2 Weight and balance

Addition of the G5(s) and supporting equipment must allow the empty weight center of gravity (CG) to fall within the aircraft's acceptable range (refer to the aircraft's POH or AFM). Perform a weight and balance computation and update the aircraft records.



6.4.3 AFMS Autopilot Information Record

Ensure that the Airplane Flight Manual Supplement (AFMS) 190-01112-13 is completed and inserted in the AFM or POH.

1. Fill in the required airplane information on the AFMS cover sheet.
2. In AFMS Section 4.4 (Autopilot Operations with the G5 HSI), fill in all applicable checkboxes corresponding to the interfaces to the autopilot. More than one box may be checked, depending upon the installation.

The G5 Electronic Flight Instrument installation in this aircraft provides the following autopilot functions (check the appropriate boxes):

- This installation does not interface with the autopilot (basic wing leveling autopilot or no autopilot is installed in the aircraft).
- A GAD 29B is installed in this aircraft.
 - Course / NAV Selection coupling to the autopilot.
 - Heading Bug coupling capability to the autopilot.
 - Roll Steering (GPSS) emulated via heading mode.

OR

- Roll Steering capable autopilot (GPSS menu function for emulation not applicable).
3. Insert the completed AFMS into the AFM or POH.

This area intentionally blank

APPENDIX A CONNECTOR INFORMATION

A.1 G5

A.1.1 J51

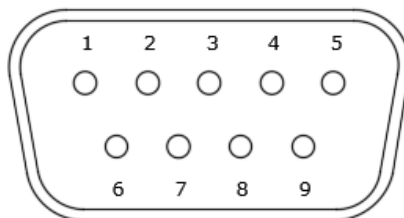

Figure 6-5 J51 on the G5

J51 Pin Descriptions

Pin	Pin Name	I/O
1	CAN-H	I/O
2	CAN-L	I/O
3	UNIT ID	In
4	RS-232 RX 1	In
5	RS-232 TX 1	Out
6	SIGNAL GROUND	--
7	AIRCRAFT POWER 1	In
8	AIRCRAFT POWER 2	In
9	POWER GROUND	--

A.1.2 Aircraft Power

The G5 operates using power from one 14 / 28 VDC input. Pin 8 (AIRCRAFT POWER 2) is not used as a part of this STC.



NOTE

AIRCRAFT POWER 2 is for connecting to an alternate power source, such as on aircraft with two electrical buses.

A.1.3 RS-232

The G5 has one RS-232 channel that may be used to interface to an existing GPS navigator or GPS source to receive GPS data for attitude aiding. Also, the G5 RS-232 port can be used to receive VHF and GPS navigation information.

For specific configuration settings for RS-232 refer to Section 6.3.6.2.

If an existing connection is made to the RS-232 port, the G5 connection can be spliced into the existing wiring at the connector. For specific wiring information refer to Section 5.

A.1.4 CAN

The G5 CAN bus conforms to the BOSCH standard for Controller Area Network (CAN) 2.0-B and ISO 11989. See Section 0 for details. The G5 can utilize CAN BUS connections when specified by a specific equipment configuration to allow heading information from the GMU 11, communication of navigation data from the GAD 29/29B and communication between the G5 Attitude or Turn Coordinator and the G5 HSI.

For specific wiring information refer to Section 5.

A.1.5 Unit ID

The G5 detects its assigned unit type at startup by checking the UNIT ID pin. This pin can be strapped into the following configurations. A maximum of two G5 units may be used in a single installation.

Unit ID Configurations

Unit ID	Comment
G5 #1	Pin 3 No Connection
G5 #2	Ground pin 3

A.2 GMU 11

A.2.1 J111

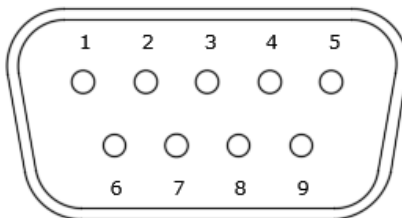

Figure 6-6 J111 on the GMU 11

J111 Pin Descriptions

Pin	Pin Name	I/O
1	CAN-H	I/O
2	CAN-L	I/O
3	UNIT ID	In
4	RS-232 RX 1	In
5	RS-232 TX 1	Out
6	SIGNAL GROUND	--
7	AIRCRAFT POWER 1	In
8	AIRCRAFT POWER 2	In
9	POWER GROUND	--



A.2.2 Aircraft Power

The GMU 11 operates using power from one 14 / 28 VDC input. Pin 8 (AIRCRAFT POWER 2) is not used as a part of this STC.



NOTE

AIRCRAFT POWER 2 is for connecting to an alternate power source, such as on aircraft with two electrical buses.

A.2.3 RS-232

RS-232 is not used or approved for use by this STC.

A.2.4 CAN Bus

The GMU 11 CAN bus conforms to the BOSCH standard for Controller Area Network (CAN) 2.0-B and ISO 11898. See Section 0 for details. The CAN bus connection on the GMU 11 is used to connect the GMU 11 to one or two G5s and a GAD 29/29B.

For specific wiring information refer to Section 5.

A.2.5 Unit ID

The GMU 11 detects its assigned unit type at startup by checking the UNIT ID pin. Only one GMU 11 may be installed by this STC. Ensure pin 3 is not connected to allow the GMU 11 to properly detect its assigned unit type.

Unit ID Configurations

Unit ID	Comment
GMU 11 #1	Pin 3 No Connection
GMU 11 #2 (Not Used)	Ground pin 3 (Not Used)

This area intentionally blank

A.3 GAD 29/29B

A.3.1 J291

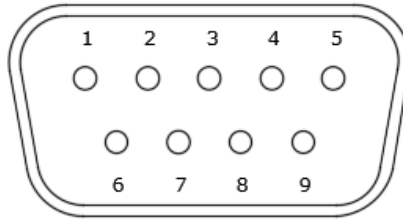

Figure 6-7 J291 on the GAD 29/29B

J291 Pin Descriptions

Pin	Pin Name	I/O
1	CAN-H	I/O
2	CAN-L	I/O
3	RESERVED	--
4	RESERVED	--
5	RESERVED	--
6	GROUND	--
7	AIRCRAFT POWER 1	In
8	AIRCRAFT POWER 2	In
9	GROUND	--

A.3.2 J292

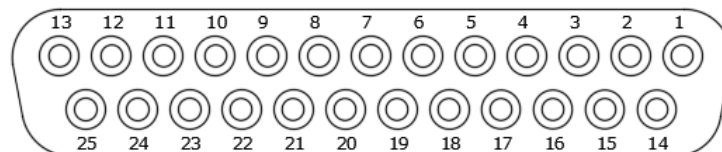

Figure 6-8 J292 on the GAD 29/29B

J292 Pin Descriptions

Pin	Pin Name	I/O
1	AC REFERENCE HI (GAD 29B ONLY)	In
2	AC REFERENCE LO (GAD 29B ONLY)	In
3	HDG/CRS VALID (GAD 29B ONLY)	Out
4	ARINC 429 IN 4B	In
5	ARINC 429 IN 3B	In
6	ARINC 429 OUT 2B	Out

7	ARINC 429 OUT 2B	Out
8	HEADING ERROR HI (GAD 29B ONLY)	Out
9	CAN TERM 1	--
10	ARINC 429 IN 2B	In
11	ARINC 429 IN 1B	In
12	ARINC 429 OUT 1B	Out
13	ARINC 429 OUT 1B	Out
14	HEADING ERROR LO (GAD 29B ONLY)	In
15	COURSE ERROR HI (GAD 29B ONLY)	Out
16	ARINC 429 IN 4A	In
17	ARINC 429 IN 3A	In
18	ARINC 429 OUT 2A	Out
19	ARINC 429 OUT 2A	Out
20	COURSE ERROR LO (GAD 29B ONLY)	In
21	CAN TERM 2	--
22	ARINC 429 IN 2A	In
23	ARINC 429 IN 1A	In
24	ARINC 429 OUT 1A	Out
25	ARINC 429 OUT 1A	Out

A.3.3 Aircraft Power

The GAD 29/29B operates using power from one 14 / 28 VDC input. Pin 8 (AIRCRAFT POWER 2) is not used as a part of this STC.



NOTE

AIRCRAFT POWER 2 is for connecting to an alternate power source, such as on aircraft with two electrical buses.

A.3.4 RS-232

RS-232 is not used or approved for use by this STC.

A.3.5 CAN Bus

The GAD 29/29B CAN bus conforms to the BOSCH standard for Controller Area Network (CAN) 2.0-B and ISO 11898. See Section 3.4.5.2 for details. The CAN bus connection on the GAD 29/29B is used to connect the GAD 29/29B to one or two G5s and a GMU 11.

For specific wiring information refer to Section 5.

A.3.6 ARINC 429

The ARINC 429 outputs conform to ARINC 429 electrical specifications when loaded with up to 5 standard ARINC 429 receivers. The G5 in conjunction with the GAD 29/29B can receive GPS and VHF navigation data and send selected course when connected to a GPS or GPS/VHF navigator.

For specific wiring information refer to Section 5



A.3.7 Autopilot Heading/Course (GAD 29B Only)

The GAD 29B can provide analog heading and course error outputs to third-party analog autopilots. In the case of an AC autopilot, the GAD 29B has an AC REFERENCE signal input.

For specific wiring information refer to Section 5.

This area intentionally blank

APPENDIX B OUTLINE AND INSTALLATION DRAWINGS

B.1 G5

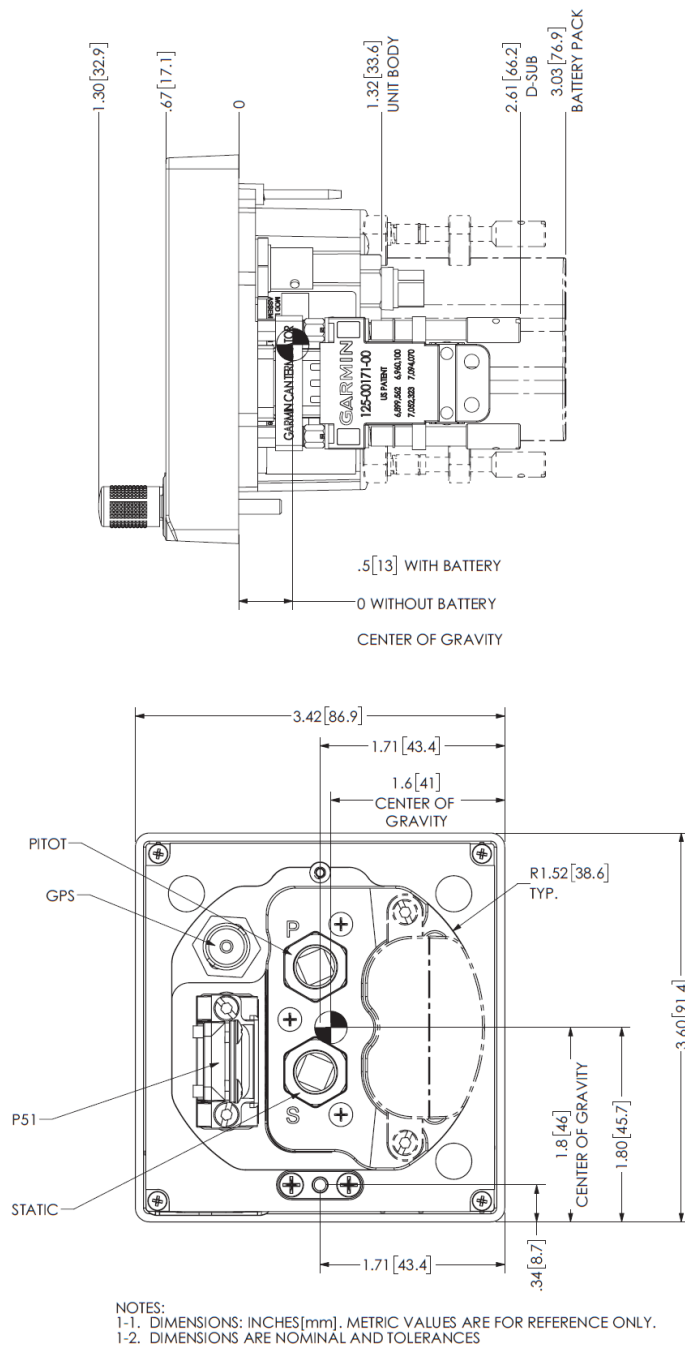

Figure 6-9 G5 Outline Drawing

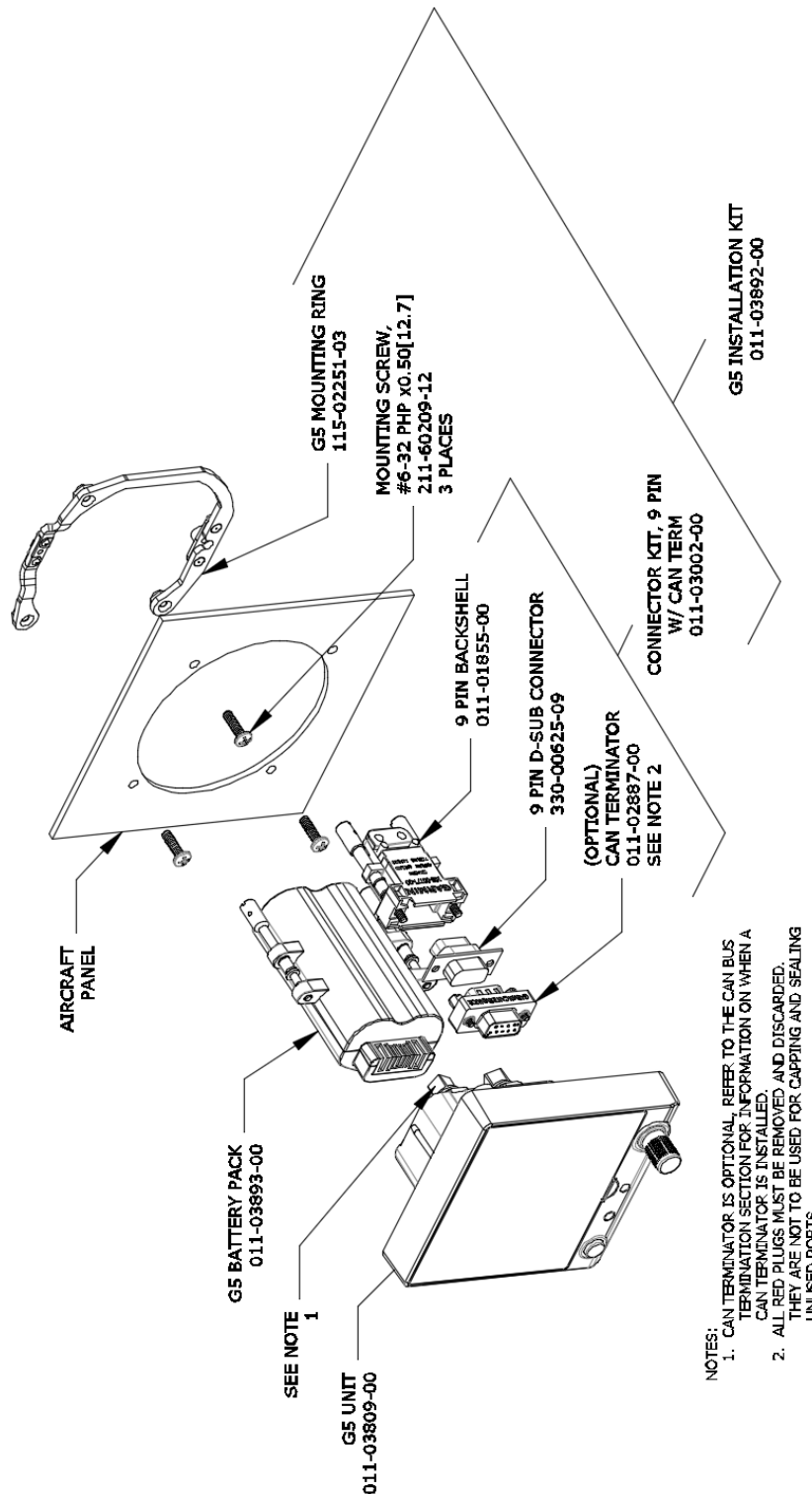

Figure 6-10 G5 Installation Drawing

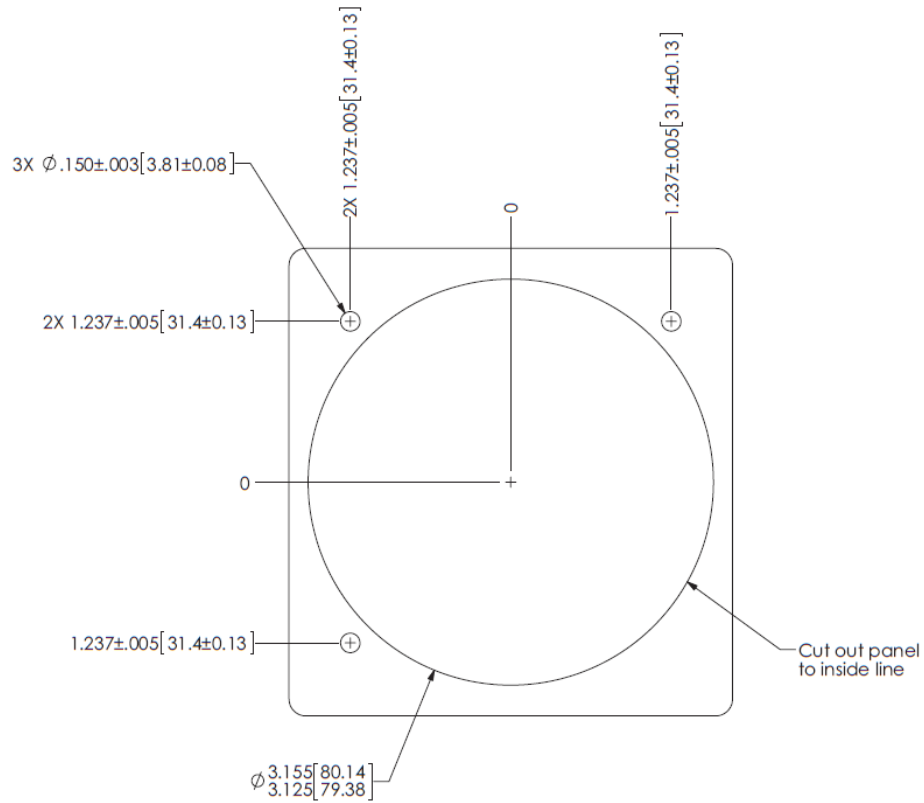

Figure 6-11 G5 Panel Cutout Measurements (Not to Scale)

This area intentionally blank

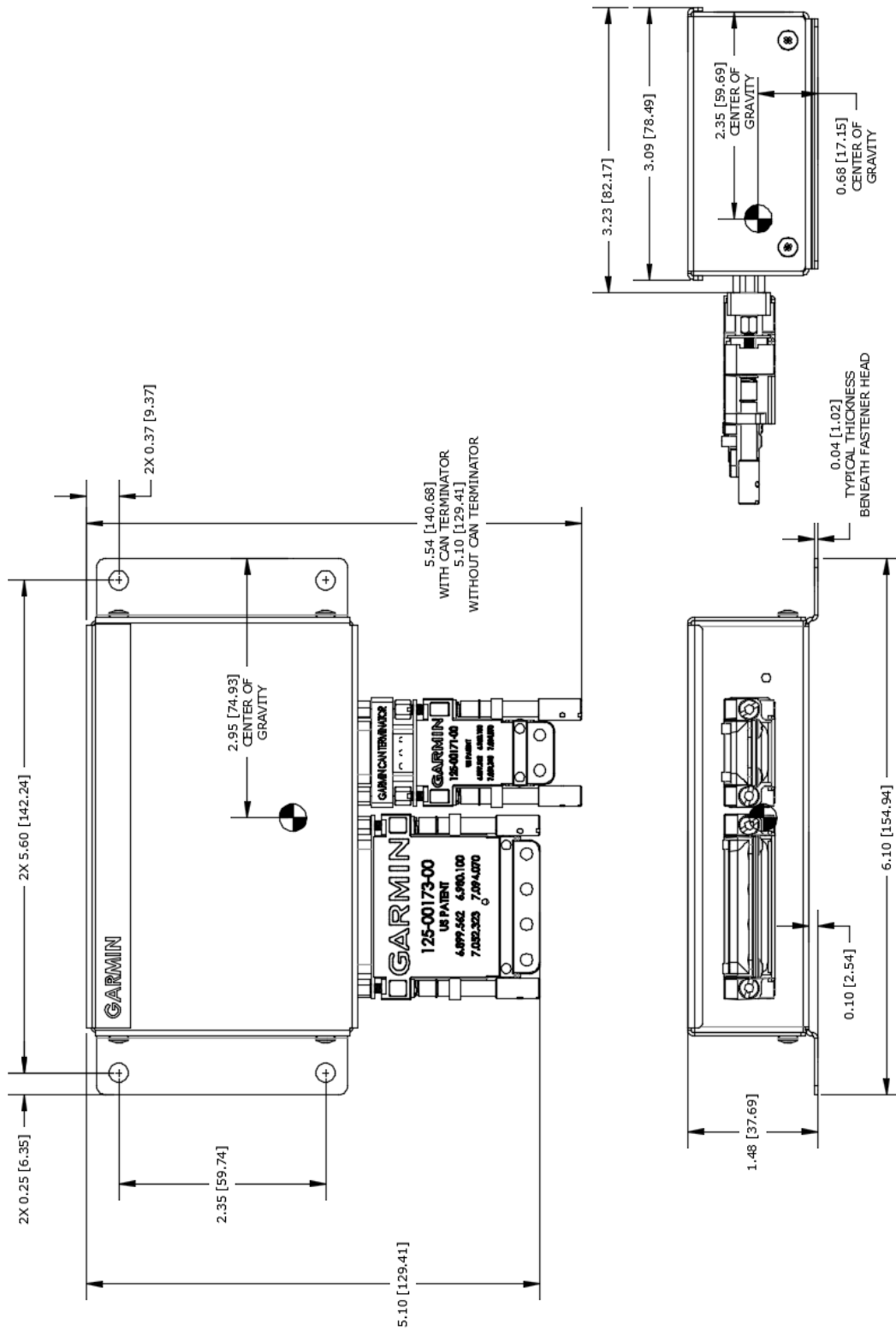

Figure 6-12 GAD 29/29B Outline Drawing

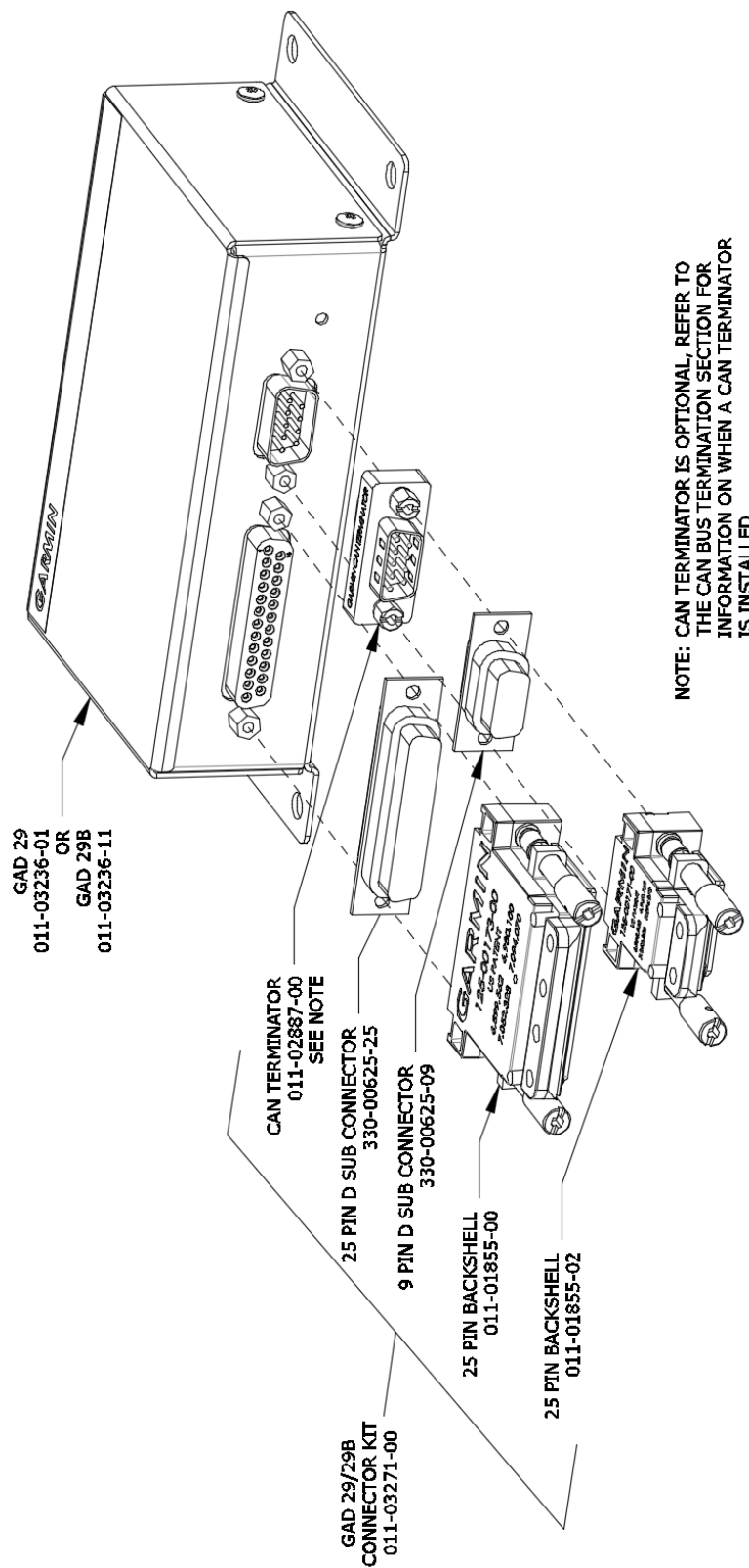

Figure 6-13 GAD 29/29B Install Breakdown

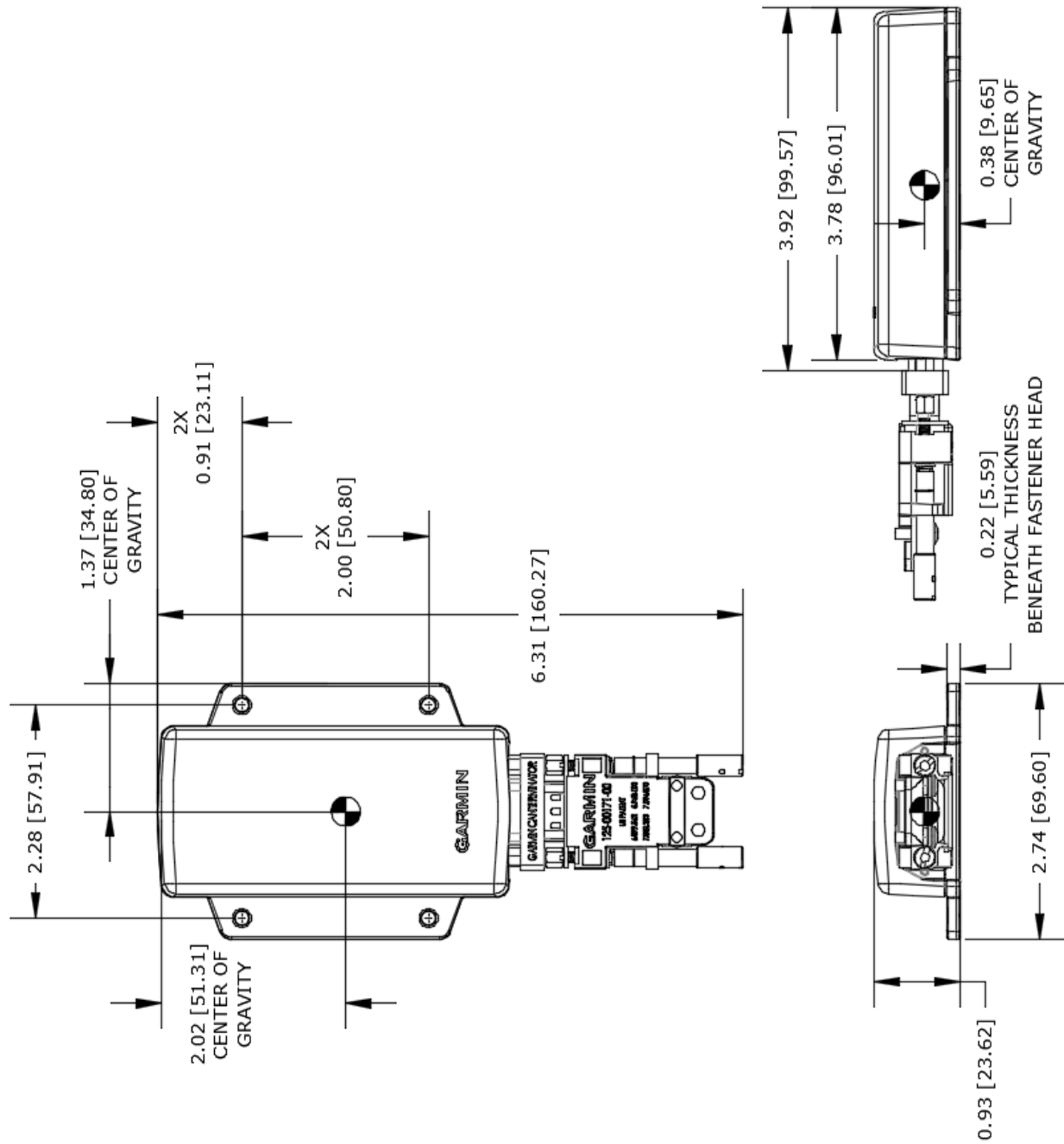
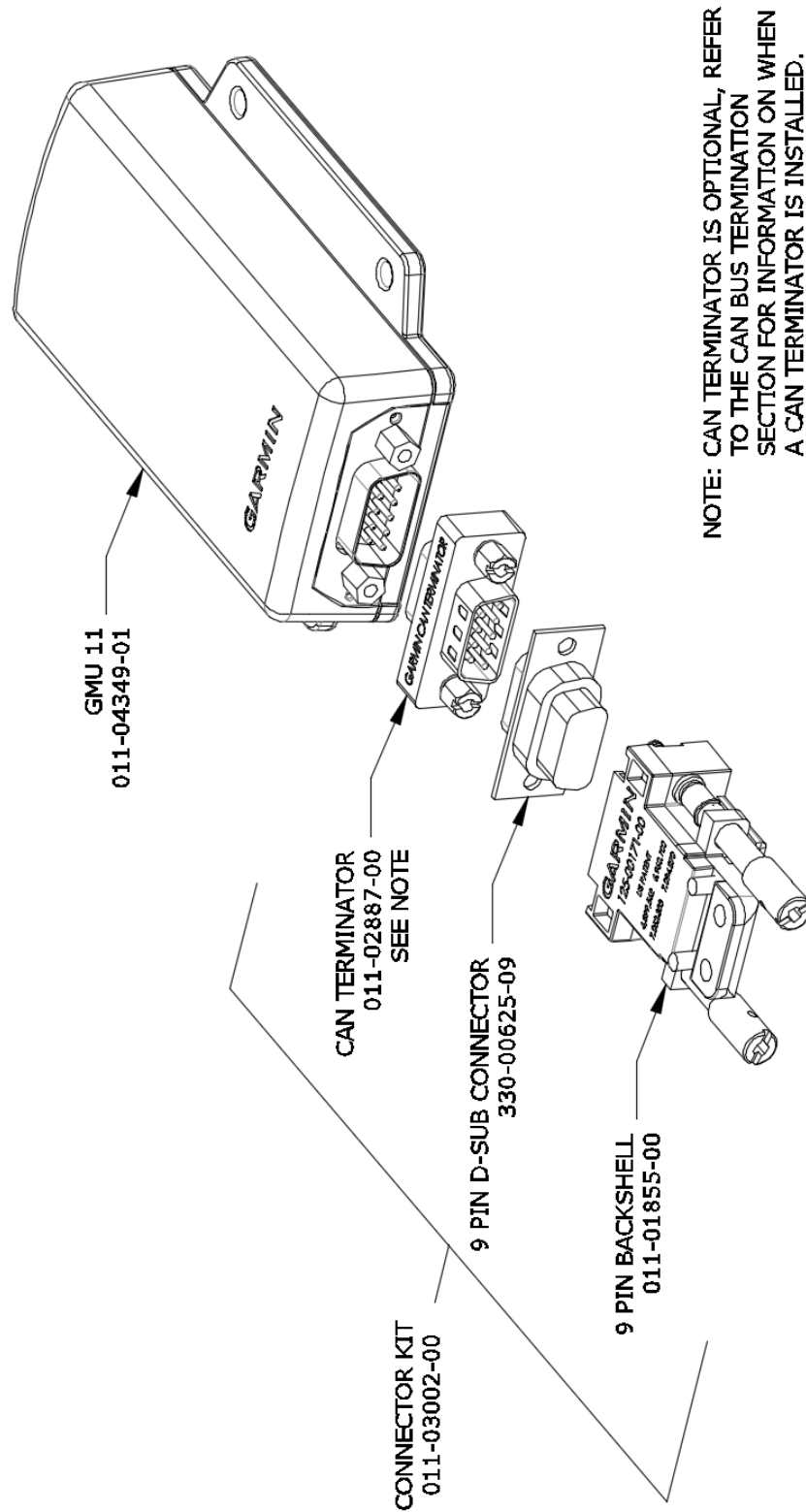

Figure 6-14 GMU 11 Outline Drawing



NOTE: CAN TERMINATOR IS OPTIONAL, REFER TO THE CAN BUS TERMINATION SECTION FOR INFORMATION ON WHEN A CAN TERMINATOR IS INSTALLED.

Figure 6-15 GMU 11 Install Breakdown



APPENDIX C MAGNETIC INTERFERENCE SURVEY

C.1 Introduction

The magnetic interference survey is used to identify a location within an aircraft with acceptable levels of magnetic interference where the GMU 11 can be correctly installed. This appendix describes the materials, precautions, setup, and procedures required to successfully conduct the magnetic interference survey.

C.2 Required Materials

The following items are required to complete the magnetic interference survey.

DC Power Source

In order to perform the magnetic interference survey, it is required to use a DC power source capable of supplying 8-36 VDC/350 mA to the G5 and GMU 11 magnetometer for test purposes.

G5

It is required to use a G5 to run the magnetic interference survey. If a G5 with charged battery attached is used, the G5 does not need to be powered from the DC Power Source.

The GMU 11 will still need power from a DC Power Source. A good temporary power source would be a 9 VDC battery.

Stopwatch or Watch with a Second Hand

During the survey test sequence, it is required to use a stopwatch, or watch with a second hand, in order to measure the time for turning equipment on and off.

Magnetic Interference Survey Test Cable

In order to perform the magnetic interference survey, it is required to use a test cable fabricated by the installer. Fabricate a test cable in accordance with Figure 6-16.

This area intentionally blank

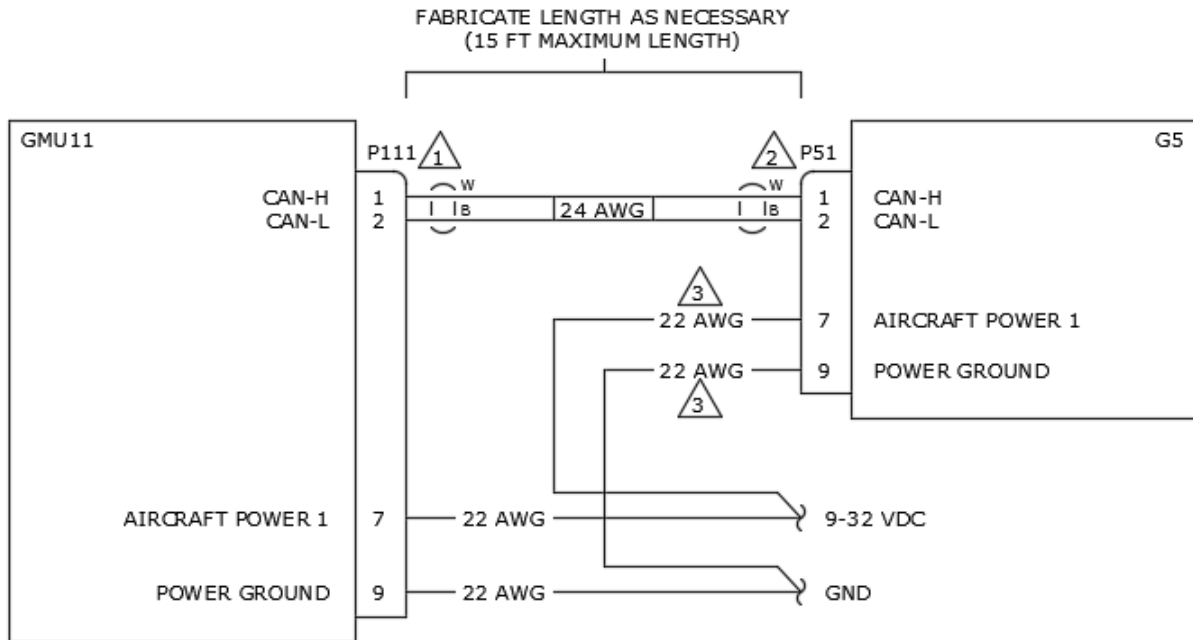

- 1 P111 IS PART OF GARMIN CONNECTOR KIT P/N 011-03002-00. ALTERNATELY, P111 CAN BE MADE USING A TE CONNECTIVITY P/N 1757820-1 OR POSITRONIC P/N RD09F0000X. INSTALL CAN TERMINATION KIT (GARMIN P/N 011-02887-00), PART OF GARMIN CONNECTOR KIT P/N 011-03002-00.
- 2 P51 IS PART OF GARMIN CONNECTOR KIT P/N 011-03002-00. ALTERNATELY, P51 CAN BE MADE USING A TE CONNECTIVITY P/N 1757820-1 OR POSITRONIC P/N RD09F0000X. INSTALL CAN TERMINATION KIT (GARMIN P/N 011-02887-00), PART OF GARMIN CONNECTOR KIT P/N 011-03002-00.
- 3 POWER AND GROUND WIRES FOR THE G5 ARE NOT REQUIRED IF A G5 WITH CHARGED BATTERY ATTACHED IS USED FOR THIS TEST SET UP.

Figure 6-16 Magnetic Interference Test Harness

C.3 Conducting the GMU 11 Location Survey

This section describes the setup and procedure required to successfully complete the GMU 11 location survey using the G5.

C.3.1 Aircraft and GMU 11 Setup

Prepare the aircraft and GMU 11 for the location survey by completing the following steps:

1. Prepare a detailed survey sequence list with start and stop times for exercising all aircraft components and devices that may affect the operation of the GMU 11 magnetometer through movement of ferrous metal parts or electrical inductance. Aircraft components included on the list will vary depending on aircraft model. An example survey sequence is provided below.
2. Position the aircraft in a magnetically quiet area. This step may involve repositioning large metal objects including aircraft and ground support equipment away from the survey area.
3. Position the GMU 11 in the aircraft location to be surveyed.



CAUTION

Do not permanently install the GMU 11 prior to successfully completing the GMU 11 location survey. An unsurveyed location may be unsuitable for permanent installation and cause the GMU 11 to function incorrectly.

Example Survey Sequence

A/C Reg.:		Survey data file name:
Elapsed Time (sec)	Elapsed Time (min:sec)	Action
0	0:00	Test begins (calibration period – no activity permitted)
20	0:20	Calibration period ends
30	0:30	Aileron full right
40	0:40	Aileron full left
50	0:50	Aileron level
60	1:00	Rudder full right
70	1:10	Rudder full left
80	1:20	Rudder neutral
90	1:30	Elevators full up
100	1:40	Elevators full down
110	1:50	Elevators neutral
120	2:00	Flaps down
140	2:20	Flaps up
160	2:40	Landing gear up
180	3:00	Landing gear down
190	3:10	Speed brake up
200	3:20	Speed brake down
210	3:30	Navigation lights on
220	3:40	Navigation lights off
230	3:50	Landing lights on
240	4:00	Landing lights off
250	4:10	Taxi lights on
260	4:20	Taxi lights off
270	4:30	Air conditioning on
280	4:40	Air conditioning off
290	4:50	Landing lights and taxi lights on
300	5:00	Landing lights and taxi lights off
310	5:10	Strobes on
320	5:20	Strobes off
330	5:30	Recognition lights on
340	5:40	Recognition lights off
350	5:50	Turn on all wingtip lights simultaneously
360	6:00	Turn off all wingtip lights simultaneously
370	6:10	Beacon on
380	6:20	Beacon off
390	6:30	Autopilot engaged in a pitch and roll made (to engage servo clutches)
400	6:40	Autopilot disengaged
410	6:50	Pitot heat on
420	7:00	Pitot heat off
430	7:10	End of test



C.3.2 G5 Tool Setup Procedure and operation

Before beginning the survey, ensure that all items listed on the test sequence are in their pre-exercise states (e.g. control surfaces neutral, flaps up, lights off). Perform the survey by completing the following steps.

1. Power up the aircraft (master switch, avionics bus, etc.).
2. Connect the test harness to the G5 with a battery installed and an 8-36 VDC/350mA limited power supply as shown in Figure 6-16 above.
3. Turn the G5 on in configuration mode.
4. Navigate to the “Magnetometer” page.
5. Select “Interference Test...”.
6. Follow the instructions displayed on the G5.
7. Select “Start” on the G5.
8. Perform each exercise on the survey sequence sheet. Perform each exercise at its specified elapsed time and for its specified duration. This will help ensure correct identification of magnetic field deviation sources after the survey is complete.
9. Monitor the magnetic field deviation percentage throughout the survey. If deviation levels exceed thresholds, mark the survey sequence exercises during which these deviations occurred.
10. When all exercises in the survey sequence have been completed, the G5 status page will display the worst case percentage of magnetic interference and the time stamp at which it occurred.

C.4 G5 Data Analysis

The G5 status page will display a “Test status:” of either “Pass” or “Fail” and the worst case percentage of magnetic interference and the time stamp at which it occurred. Use this time stamp in conjunction with the completed survey sequence to conclude which item created the highest magnetic interference. If the test passes, then the location chosen for the test is a valid candidate for mounting the GMU 11. No further testing is required.

If the test fails, the location chosen for the test should be considered unreliable until the source of magnetic interference is identified and remedied. Compare the corresponding timestamp with the prepared test sequence to identify which action produced the problem. If the source of the magnet interference is not able to be identified or remedied, a new location for testing should be chosen. Repeat the test until a suitable location is found.

This area intentionally blank

APPENDIX D GMU 11 MOUNTING IN NONMETALLIC WINGTIP

D.1 Overview

In some installations it is desirable to mount the GMU 11 magnetometer in the wingtip of a metal aircraft that has non-metallic (e.g. fiberglass) wingtip covers. If this is the case, the following requirements must be met:

- The aircraft must have wingtip navigation lights installed.
- Heavy overbraid must be installed over the wiring from the GMU to the entry into the wing.
- The overbraid must be terminated at this wing entry point using a #10 terminal lug and stud.
- The GMU 11 must be mounted to a metal rib that does not enclose a fuel bay.
- There must be at least one intermediate rib between the rib that encloses the fuel bay and the rib on which the GMU 11 is installed.
- The GMU 11 mounting bracket must be electrically bonded to the wing using fasteners or rivets.

D.2 Materials Required but Not Supplied

The following materials (or equivalents) are required to install the GMU 11 in a non-metallic wingtip:

- Tinned copper flat braid, 1/4", QQB575F36T0250
- Electrical tie-down strap, adjustable, MS3367-{1, 2, or 7}-X
- Terminal lug, #10, uninsulated, MS25036-108
- Terminal stud, #10
- Terminal lug, #8, uninsulated, MS25036-153

D.3 Overbraid Fabrication and Installation

The length of overbraid required is approximately equal to the length of the GMU 11 service loop (measured from the wing rib to the collar of P111) plus 4 inches.

Refer to Figure 6-17 and Figure 6-18 while completing the following overbraid installation procedure:



NOTE

It is recommended this procedure is completed prior to terminating wires to connector P111. If this procedure is completed before assembly of P111, proceed to step 3.

1. Disconnect P111 from the GMU 11.
2. De-pin wires from P111 to facilitate placing overbraid over wire bundle.
3. Slide the overbraid over wire bundle extending from wing rib.
4. Terminate the end nearest the metal wing rib with the overbraid in accordance with one of the two methods in Section 0 using a #8 terminal lug.
5. Secure the overbraid pigtail to the shield block of P111 when assembling P111 (Refer to Section 4.3.3).
6. Terminate the end nearest the GMU with the overbraid in accordance with one of the two methods in Section 0 using a #10 terminal lug.
7. Secure the overbraid pigtail to a #10 terminal stud. Refer to Section D.3.2 for stud location instructions.

D.3.1 Overbraid Termination Methods

Overbraid must be terminated with an appropriate lug by one of the two following approved methods. Whichever method is used, overbraid pigtail length must not exceed two inches. Refer to Figure 6-18.

Method A

1. Carefully separate overbraid wire strands by hand to create an opening in the overbraid for passage of the GMU 11 connector and cables.



CAUTION

Do not cut an opening in the overbraid strands. Loose overbraid wire ends can chafe the cable and cause the GMU 11 to malfunction.

2. Trim the overbraid pigtail to a maximum length of two inches.
3. Terminate the braid pigtail in an appropriate terminal lug.

Method B

1. Comb out a maximum of two inches of overbraid pigtail.
2. Twist the pigtail and terminate it in an appropriate terminal lug.

D.3.2 Overbraid Terminal Bonding

Electrical bond preparation for all aluminum-to-aluminum interfaces must be done in accordance with SAE ARP1870 section 5.1 and 5.5. The overbraid terminal lug must be electrically bonded to a #10 stud installed in accordance with AC43.13-1B Section 11-189, as well as the following restrictions:

1. If possible, use an existing tooling hole to install the stud.
2. If no suitable tooling hole exists, use an existing fastener (#10 or larger).
3. If there is no suitable fastener, install a new #10 stud as follows:
 - a. When adding a new stud hole to the rib, the center of the hole must be located a minimum of one inch away from any existing, non-stiffened rib hole.
 - b. The new stud hole must be located such that the terminal lug face, neck, or attaching hardware will not intrude into the flange bend radius of any rib edge or stiffened rib hole. Refer to MS25036 for terminal lug dimensions.
4. Verify overbraid terminal bonding by checking resistance between the overbraid and the rib. Resistance should be less than 2.5 mΩ.

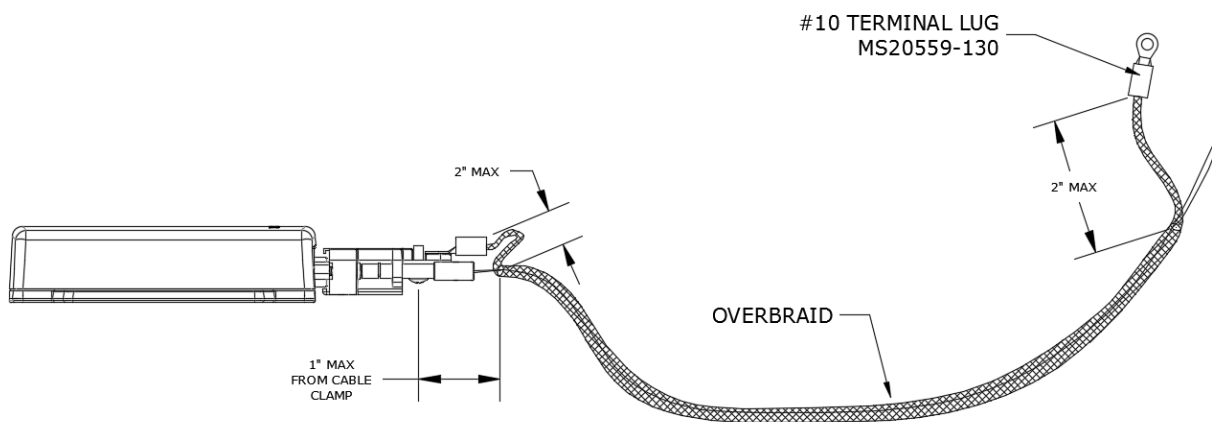
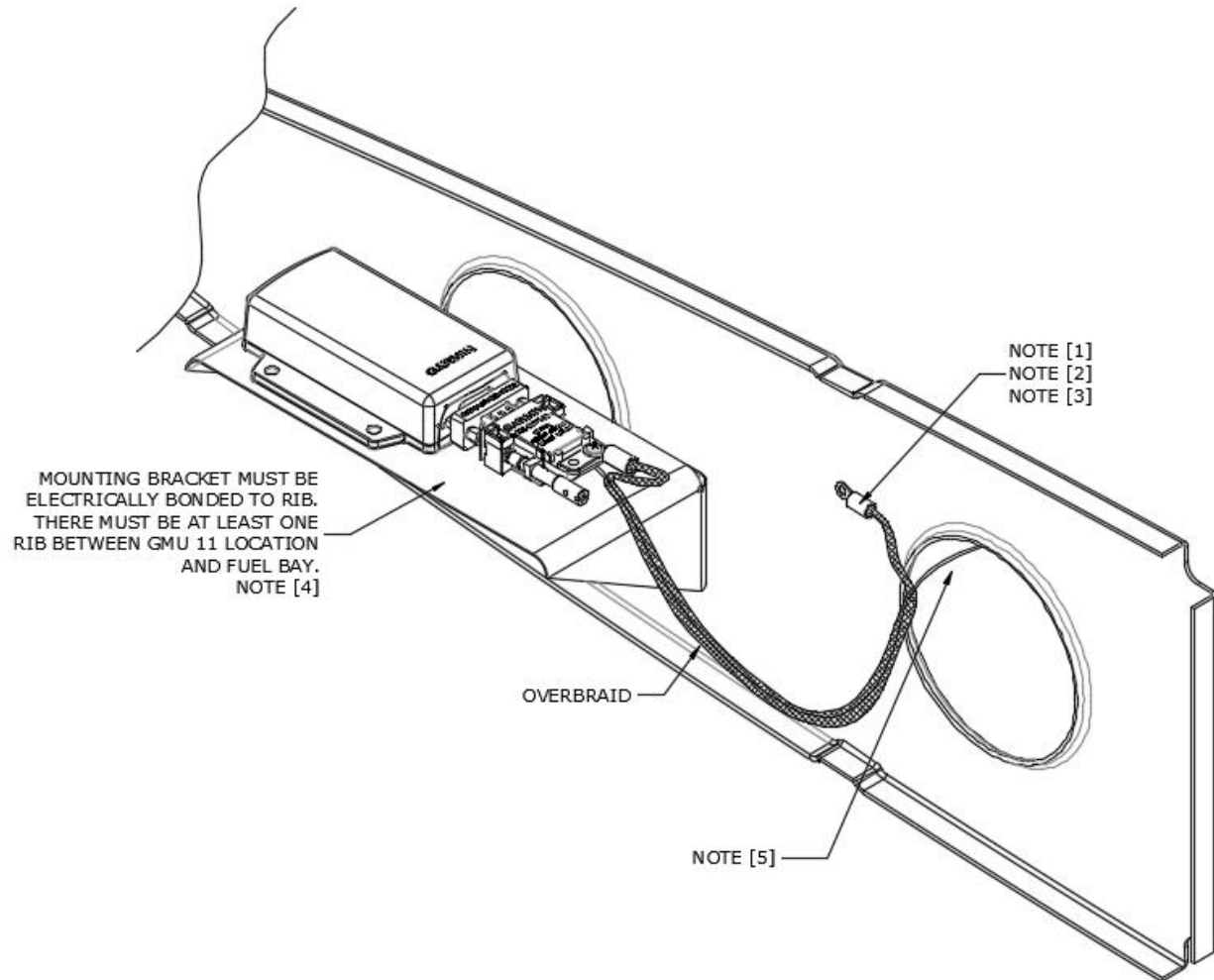

Figure 6-17 GMU 11 Overbraid Installation



NOTES:

- [1] Install #10 grounding hardware in accordance with AC 43.13-1B, section 11-89. If there is an existing hole located in an appropriate area it may be utilized for the grounding hardware. If there is no existing hole usable for this purpose then drill and de-burr a 0.191"-0.203" hole.
- [2] MS25036-103 terminal lug (or equivalent).
- [3] Terminal lug face or connecting hardware must not interfere with bend radius of rib edge or stiffened holes. Stud hole must be located a minimum 1" from unstiffened holes. Refer to MS20559 for lug dimensions.
- [4] Refer to Section 4.6 for electrical bonding requirements.
- [5] The exposed cable not having overbraid in the wing tip areas must be less than 2 inches.

Figure 6-18 GMU 11 Overbraid Termination