

G5 Electronic Flight Display Installation Manual for Non-Certified Aircraft



© 2017
Garmin Ltd. or its subsidiaries
All Rights Reserved

Except as expressly provided herein, no part of this manual may be reproduced, copied, transmitted, disseminated, downloaded or stored in any storage medium, for any purpose without the express prior written consent of Garmin. Garmin hereby grants permission to download a single copy of this manual and of any revision to this manual onto a hard drive or other electronic storage medium to be viewed and to print one copy of this manual or of any revision hereto, provided that such electronic or printed copy of this manual or revision must contain the complete text of this copyright notice and provided further that any unauthorized commercial distribution of this manual or any revision hereto is strictly prohibited.

Garmin International, Inc.
1200 E. 151st Street
Olathe, KS 66062 USA

Garmin (Europe) Ltd.
Liberty House, Hounsdown Business Park
Southampton, Hampshire SO40 9LR U.K.

AVIATION LIMITED WARRANTY

G5 warranty information is available at garmin.com/aviationwarranty.

RECORD OF REVISIONS

Revision	Revision Date	Description
1	11/01/17	Initial Release

INFORMATION SUBJECT TO EXPORT CONTROL LAWS

This document may contain information which is subject to the Export Administration Regulations (“EAR”) issued by the United States Department of Commerce (15 CFR, Chapter VII Subchapter C) and which may not be exported, released or disclosed to foreign nationals inside or outside the United States without first obtaining an export license. The preceding statement is required to be included on any and all reproductions in whole or in part of this manual.

CURRENT REVISION DESCRIPTION

Revision	Page Number	Section Number	Description of Change
1	iv–viii	Front	Added software license agreement info
	2-9	2.2.8	Added CAN Diagnostic Page info, Figure 2-11
	7-1, 7-9–7-13	7	Updated Figure 7-1 and Figure 7-9 , added Figure 7-10 , Figure 7-11 , Figure 7-12 and Figure 7-13
	8-5, 8-6	8.4.2	Updated Attitude Configuration Settings in Table 8-1
	8-8	8.4.3	Updated Air Data Configuration Settings in Table 8-2
	8-42	8.4.7.9	Updated Autopilot Roll Servo Configuration Settings in Table 8-7
	8-52, 8-53	8.4.9	Added Electronic Stability Protection section
	8-63, 8-64	8.4.13.4	Updated RS-232 Configuration Page info
	8-65	8.4.13.5	Updated ARINC 429 Configuration Page info

DEFINITIONS OF WARNINGS, CAUTIONS, AND NOTES



WARNING

A warning means injury or death is possible if the instructions are not obeyed.



CAUTION

A caution means that damage to the equipment is possible.



NOTE

A note gives more information.



WARNING

If these guidelines are not followed, the lithium-ion battery may experience a shortened life span or may present a risk of damage to the device, fire, chemical burn, electrolyte leak, and/or injury.

- *Do not leave the battery exposed to a heat source or in a high temperature environment. To help prevent damage, store the battery out of direct sunlight.*
- *For maximum battery longevity, store within a temperature range of -4° to 68°F (from -20° to 20°C).*
- *Do not use a sharp object to remove the battery.*
- *Do not disassemble, puncture, damage, or incinerate the device or battery.*
- *Keep the battery away from children.*
- *Only replace the battery with the approved replacement from Garmin. Using another battery presents a risk of fire or explosion. To purchase a replacement battery, see you Garmin dealer or the Garmin website.*
- *Contact your local waste disposal department to dispose of the device and battery in accordance with applicable local laws and regulations.*



WARNING

To reduce the risk of unsafe operation, carefully review and understand all aspects of the G5 Install Manual & Pilot's Guide documentation and the Pilot's Operating Handbook of the aircraft. Thoroughly practice basic operation prior to actual use. During flight operations, carefully compare indications from the G5 to all available flight displays. For safety purposes, always resolve any discrepancies.



WARNING

This product, its packaging, and its components contain chemicals known to the State of California to cause cancer, birth defects, or reproductive harm. This Notice is being provided in accordance with California Proposition 65. If you have any questions or would like additional information, please refer to our website at www.garmin.com/prop65

**CAUTION**

The display uses a lens with a special coating that may be sensitive to certain oils, waxes, and abrasive cleaners. CLEANERS CONTAINING AMMONIA WILL HARM THE ANTI-REFLECTIVE COATING. It is very important to clean the lens using a clean, lint-free cloth and a cleaner that is specified as safe for anti-reflective coatings. Avoid any chemical cleaners or solvents that can damage plastic components.

**CAUTION**

The G5 does not contain any user-serviceable parts. Repairs should only be made by an authorized Garmin service center. Unauthorized repairs or modifications could result in permanent damage to the equipment and void both the warranty and the authority to operate this device under FAA, FCC, and other applicable regulations.

**NOTE**

The G5 may only be installed in type-certificated aircraft in accordance with Garmin STC SA01818WI.

**NOTE**

The term LRU, as used throughout this manual is an abbreviation for Line Replaceable Unit. LRU is used generically in aviation for a product (such as a GSA 28 or GMC 307) that can be readily "swapped out" (usually as a single component) for troubleshooting/repair.

SOFTWARE LICENSE AGREEMENT FOR GARMIN AVIATION PRODUCTS

The software embedded in your Garmin product (the “Licensed Software”) is owned by Garmin International, Inc. (“Garmin” or “us”). The Licensed Software is protected under copyright laws and international copyright treaties. The Licensed Software is provided under this Software License Agreement (hereinafter the “Agreement”) and is subject to the following terms and conditions which are agreed to by End User (“Licensee”, “you” or “your”), on the one hand, and Garmin and its licensors and affiliated companies of Garmin and its licensors, on the other hand. The Licensed Software is licensed, not sold, to you. Garmin and Licensee may be referred to individually as a “Party” or jointly as the “Parties.”

IMPORTANT: CAREFULLY READ THIS ENTIRE AGREEMENT BEFORE USING THIS PRODUCT. INSTALLING, COPYING, OR OTHERWISE USING THIS PRODUCT INDICATES YOUR ACKNOWLEDGMENT THAT YOU HAVE READ THIS AGREEMENT AND AGREE TO ITS TERMS AND CONDITIONS. IF YOU DO NOT AGREE TO THESE TERMS AND CONDITIONS, YOU MAY NOT USE THIS PRODUCT.

1. **Definitions.** The following capitalized terms shall have the meanings set forth below:

- 1.1 “Device” means any Garmin device that is delivered by or on behalf of Garmin to Licensee onto which the Licensed Software is installed.
- 1.2 “Documentation” means Garmin’s then-current instructional, technical or functional documentation relating to the Devices or Licensed Software which is delivered or made available by Garmin in connection with this Agreement.
- 1.3 “Licensed Software” means the software in binary executable form that is embedded in the Devices and/or made available for use on the Devices via a software loader card.
- 1.4 “Permitted Purpose” means operating and using the Device on which the Licensed Software is installed for the Device’s intended use.

2. **License.**

- 2.1 License Grant. Subject to the terms and conditions of this Agreement and Licensee’s compliance with the terms and conditions of this Agreement, Garmin hereby grants to Licensee a limited, royalty-free, non-exclusive, non-sublicenseable, non-transferable and revocable right and license to use and perform the Licensed Software as installed on the Devices and the Documentation solely for the Permitted Purpose and only during the term of this Agreement, provided that the Licensed Software may only be used by Licensee on Devices on which the Licensed Software has been installed or otherwise made available by Garmin.
- 2.2 Reservation of Rights. Garmin retains exclusive ownership of all right, title and interest in and to the Licensed Software and Documentation. All of Garmin’s rights in and to the Licensed Software and Documentation not expressly licensed to Licensee under Section 2.1 are expressly reserved for Garmin. Nothing contained in this Agreement shall be construed as conferring by implication, acquiescence, or estoppel any license or other right upon Licensee. Without limiting the foregoing, the Parties acknowledge and agree that this Agreement grants Licensee a license of the Licensed Software under the terms of Section 2.1, and shall not in any manner be construed as a sale of the Licensed Software or any rights in the Licensed Software.

3. Restrictions: Protection and Third Party Devices.

- 3.1 Prohibited Uses. Licensee shall not, shall not attempt to and shall not permit any third party to: (a) sublicense, lease, loan, sell, resell, market, transfer, rent, disclose, demonstrate, or distribute the Licensed Software or Documentation to any third party; (b) uninstall the Licensed Software from the Device on which it was originally installed; (c) make any use of or perform any acts with respect to the Licensed Software or Documentation other than as expressly permitted in accordance with the terms of this Agreement; (d) use the Licensed Software or Documentation in any manner that violates any applicable law; (e) reproduce or copy the Licensed Software; (f) modify, adapt, alter, translate, port, create derivative works of, reverse engineer, decompile or disassemble the Licensed Software or Documentation or otherwise derive the source code or other proprietary information or trade secrets from the Licensed Software; (g) remove, alter, or obscure any proprietary notices from the Licensed Software or Documentation; (h) use the Licensed Software or Documentation to provide services to third parties (such as business process outsourcing, service bureau applications or third party training); (i) use the Licensed Software on any equipment, hardware or device other than a Device; or (j) export, re-export or otherwise distribute, directly or indirectly, the Licensed Software or Documentation to a jurisdiction or country to which the export, re-export or distribution of such Licensed Software or Documentation is prohibited by applicable law.
- 3.2 Protection of Software and Documentation. Licensee shall use its best efforts to protect the Licensed Software and Documentation from unauthorized access, distribution, modification, display, reproduction, disclosure or use with at least the same degree of care as Licensee normally uses in protecting its own software and documentation of a similar nature from unauthorized access, distribution, modification, display, reproduction, disclosure or use. Licensee shall limit access to the Licensed Software and Documentation to only those employees of Licensee who require access to the Licensed Software or Documentation for the Permitted Purpose and who have been made aware of the restrictions set forth in this Agreement. Licensee shall take prompt and appropriate action to prevent unauthorized use or disclosure of the Licensed Software and Documentation.

4. Term and Termination.

- 4.1 Term. The term of this Agreement shall commence on the Effective Date, and shall continue in perpetuity thereafter, unless terminated earlier as provided in this Section 4.
- 4.2 Termination by Garmin. Garmin may immediately terminate this Agreement upon written notice to Licensee if Licensee commits a material breach of this Agreement or breaches a material term of this Agreement.
- 4.3 Effect of Termination. Upon any termination of this Agreement for any Party : (a) Licensee shall immediately cease all use of the Licensed Software and Documentation; (b) all rights and licenses granted to Licensee to the Licensed Software and Documentation and Garmin's related obligations shall immediately terminate; and (c) Sections 4.3, 5 and 6 shall survive.

5. **Disclaimer; Limitations of Liability; Indemnity.**

- 5.1 **DISCLAIMER.** TO THE MAXIMUM EXTENT PERMITTED BY APPLICABLE LAW, THE LICENSED SOFTWARE AND DOCUMENTATION (INCLUDING ANY RESULTS TO BE OBTAINED FROM ANY USE OF THE LICENSED SOFTWARE AND DOCUMENTATION) ARE PROVIDED “AS IS” AND “AS AVAILABLE” WITH NO WARRANTIES, GUARANTEES OR REPRESENTATIONS AND NEITHER GARMIN NOR ITS AFFILIATES MAKE ANY REPRESENTATION, WARRANTY OR GUARANTEE, STATUTORY OR OTHERWISE, UNDER LAW OR FROM THE COURSE OF DEALING OR USAGE OF TRADE, EXPRESS OR IMPLIED, INCLUDING ANY WARRANTIES OF MERCHANTABILITY, FITNESS FOR A PARTICULAR PURPOSE, NON-INTERFERENCE, NON-INFRINGEMENT, TITLE, OR SIMILAR, UNDER THE LAWS OF ANY JURISDICTION. GARMIN DOES NOT WARRANT THAT THE LICENSED SOFTWARE OR DOCUMENTATION WILL MEET LICENSEE’S REQUIREMENTS OR THAT OPERATION OF THE SOFTWARE WILL BE UNINTERRUPTED OR ERROR FREE. LICENSEE ASSUMES THE ENTIRE RISK AS TO THE QUALITY AND PERFORMANCE OF THE LICENSED SOFTWARE AND DOCUMENTATION. THE LICENSED SOFTWARE IS NOT INTENDED FOR USE IN ANY NUCLEAR, MEDICAL, OR OTHER INHERENTLY DANGEROUS APPLICATIONS, AND GARMIN DISCLAIMS ALL LIABILITY FOR ANY DAMAGE OR LOSS CAUSED BY SUCH USE OF THE LICENSED SOFTWARE.
- 5.2 **EXCLUSION OF DAMAGES; LIMITATION OF LIABILITY.** NOTWITHSTANDING ANYTHING TO THE CONTRARY HEREIN, TO THE MAXIMUM EXTENT PERMITTED BY APPLICABLE LAW, UNDER NO CIRCUMSTANCES AND REGARDLESS OF THE NATURE OF ANY CLAIM SHALL GARMIN BE LIABLE TO LICENSEE FOR AN AMOUNT IN EXCESS OF \$100, OR BE LIABLE IN ANY AMOUNT FOR ANY SPECIAL, INCIDENTAL, CONSEQUENTIAL, PUNITIVE OR INDIRECT DAMAGES, LOSS OF GOODWILL OR PROFITS, LIQUIDATED DAMAGES, DATA LOSS, COMPUTER FAILURE OR MALFUNCTION, ATTORNEYS’ FEES, COURT COSTS, INTEREST OR EXEMPLARY OR PUNITIVE DAMAGES, ARISING OUT OF OR IN CONNECTION WITH THE USE OR PERFORMANCE OR NON-PERFORMANCE OF THE LICENSED SOFTWARE OR DOCUMENTATION, EVEN IF GARMIN HAS BEEN ADVISED OF THE POSSIBILITY OF SUCH LOSS OR DAMAGES.
- 5.3 **Indemnity.** Licensee shall indemnify, defend and hold Garmin and its affiliates harmless against any and all losses, claims, actions, causes of action, liabilities, demands, fines, judgments, damages and expenses suffered or incurred by Garmin or its affiliated companies in connection with: (a) any use or misuse of the Licensed Software or Documentation by Licensee or any third party in Licensee’s reasonable control; or (b) Licensee’s breach of this Agreement.

6. General.

- 6.1 No Devices or Services. Licensee acknowledges and agrees that nothing in this Agreement shall be construed as requiring Garmin to: (a) provide or supply the Devices or any other devices or hardware to Licensee; (b) grant any licenses to any software other than the Licensed Software; or (c) provide any services, such as support, maintenance, installation or professional services for the Licensed Software.
- 6.2 Non-Exclusive. Each Party's rights and obligations under this Agreement are non-exclusive. Garmin is not precluded from marketing, licensing, providing, selling or distributing the Licensed Software or Documentation, or any other products, software, documentation or services, either directly or through any third party.
- 6.3 Assignment. Licensee may not assign this Agreement or any of its rights, interests or obligations hereunder without the prior written consent of Garmin. Any purported assignment in violation of this Section 6.3 shall be null and void. Subject to the foregoing, this Agreement shall be binding upon and shall inure to the benefit of the Parties and their respective successors and permitted assigns and transferees.
- 6.4 Feedback and Data. Licensee may from time to time provide feedback, comments, suggestions, questions, ideas, or other information to Garmin concerning the Licensed Software or Documentation or Garmin's products, services, technology, techniques, processes or materials ("Feedback"). Garmin may in connection with any of its products or services freely use, copy, disclose, license, distribute and otherwise exploit such Feedback in any manner without any obligation, payment, royalty or restriction whether based on intellectual property rights or otherwise.
- 6.5 Governing Law. The validity, interpretation and enforcement of this Agreement will be governed by the substantive laws, but not the choice of law rules, of the state of Kansas. This Agreement shall not be governed by the 1980 UN Convention on Contracts for the International Sale of Goods.
- 6.6 Legal Compliance. You represent and warrant that (i) you are not located in a country that is subject to a U.S. Government embargo, or has been designated by the U.S. Government as a "terrorist supporting" country, and (ii) you are not listed on any U.S. Government list of prohibited or restricted parties.
- 6.7 Injunctive Relief. The Parties acknowledge and agree that irreparable damage would occur if any provision of this Agreement was not performed in accordance with its specific terms or was otherwise breached and as such, the Parties will be entitled to an injunction or injunctions to prevent breaches of this Agreement and to enforce specifically the performance of the terms and provisions of this Agreement without proof of actual damages, this being in addition to any other remedy to which any Party is entitled at law or in equity.

- 6.8 Amendments and Waivers. This Agreement may be amended and any provision of this Agreement may be waived, provided that any such amendment or waiver will become and remain binding upon a Party only if such amendment or waiver is set forth in a writing by such Party. No course of dealing between or among any persons having any interest in this Agreement will be deemed effective to modify, amend or discharge any part of this Agreement or any rights or obligations of any Party under or by reason of this Agreement. No delay or failure in exercising any right, power or remedy hereunder will affect or operate as a waiver thereof; nor will any single or partial exercise thereof or any abandonment or discontinuance of steps to enforce such a right, power or remedy preclude any further exercise thereof or of any other right, power or remedy. The rights and remedies hereunder are cumulative and not exclusive of any rights or remedies that any Party would otherwise have.
- 6.9 Severability. The provisions of this Agreement will be severable in the event that for any reason whatsoever any of the provisions hereof are invalid, void or otherwise unenforceable, any such invalid, void or otherwise unenforceable provisions will be replaced by other provisions which are as similar as possible in terms to such invalid, void or otherwise unenforceable provisions but are valid and enforceable and the remaining provisions will remain valid and enforceable to the fullest extent permitted by applicable law, in each case so as to best preserve the intention of the Parties with respect to the benefits and obligations of this Agreement.
- 6.10 No Third-Party Beneficiaries. This Agreement is solely for the benefit of the Parties and does not confer on third parties any remedy, claim, reimbursement, claim of action or other right in addition to those existing without reference to this Agreement.
- 6.11 Entire Agreement. This Agreement shall constitute the entire agreement between Garmin and you with respect to the subject matter hereof and will supersede all prior negotiations, agreements and understandings of Garmin and you of any nature, whether oral or written, with respect to such subject matter.
- 6.12 Interpretation. In this Agreement: (a) headings are for convenience only and do not affect the interpretation of this Agreement; (b) the singular includes the plural and vice versa; (c) the words 'such as', 'including', 'particularly' and similar expressions are not used as, nor are intended to be, interpreted as words of limitation; (d) a reference to a person includes a natural person, partnership, joint venture, government agency, association, corporation or other body corporate; a thing includes a part of that thing; and a party includes its successors and permitted assigns; and (e) no rule of construction applies to the disadvantage of a Party because that Party was responsible for the preparation of this Agreement. Any translation of this Agreement from English is provided as a convenience only. If this Agreement is translated into a language other than English and there is a conflict of terms between the English version and the other language version, the English version will control.

TABLE OF CONTENTS

PARAGRAPH	PAGE
1 Installation Information	1-1
1.1 Introduction	1-1
1.2 G5 Overview.....	1-1
1.3 Inventory of Materials	1-2
1.4 Unpacking the Unit.....	1-2
1.5 Garmin Equipment	1-3
1.6 Non-Garmin Equipment	1-4
1.7 Garmin Software and Documents.....	1-4
2 Installation Preparation.....	2-1
2.1 Electrical Considerations	2-1
2.2 Wiring/Cabling Considerations	2-2
2.3 Mechanical Considerations.....	2-10
3 G5 Installation	3-1
3.1 Primary Functions.....	3-1
3.2 General Specifications	3-1
3.3 Installation Information	3-1
3.4 Unit Installation	3-2
3.5 Antennas	3-4
3.6 Mounting Instructions.....	3-5
3.7 Outline and Installation Drawings.....	3-9
4 GPS Antenna Installation.....	4-1
4.1 Non-Garmin Antennas.....	4-1
4.2 Garmin Antennas	4-1
5 G5 Pinout	5-1
5.1 J51 Connector	5-1
6 Connector Installation Instructions.....	6-1
6.1 Shield Block Installation Parts	6-1
6.2 Shield Termination Technique – Method A.1 (Standard)	6-3
6.3 Shield Termination Technique – Method A.2 (Daisy Chain)	6-7
6.4 Shield Termination Technique – Method B.1 (Quick Term)	6-8
6.5 Shield Termination Technique – Method B.2 (Daisy Chain-Quick Term).....	6-11
6.6 Daisy Chain between Methods A.1 and B.1	6-12
6.7 Unit ID (Strapping).....	6-13
6.8 Splicing Signal Wires	6-14

7 Interconnect Drawings.....	7-1
8 G5 Configuration and Post Installation Checkout.....	8-1
8.1 Recommended Test Equipment.....	8-1
8.2 Configuration Mode	8-2
8.3 Software Loading Procedure	8-2
8.4 Configuration Pages	8-3
9 Troubleshooting.....	9-1
9.1 General Troubleshooting	9-1
9.2 SD Card Slot.....	9-2
9.3 Unit Communication Error	9-2
9.4 Air Data Troubleshooting.....	9-2
9.5 Attitude Failure Troubleshooting	9-2
9.6 Heading Failure Troubleshooting (with GMU 11).....	9-3
9.7 G5 Data Logging	9-3
9.8 Sending Troubleshooting Data to Garmin.....	9-3
10 Maintenance.....	10-1
10.1 G5 Air Data Periodic Maintenance	10-1
10.2 G5 Battery Periodic Maintenance.....	10-1
10.3 Return to Service Information	10-1
11 Performance Specifications/Licensing/Compliance	11-1
11.1 GPS Specifications	11-1
11.2 G5 Environmental Specifications	11-1
11.3 G5 Performance Specifications	11-2
11.4 RS-232 Text Output Format.....	11-3

1 INSTALLATION INFORMATION

1.1 Introduction

This manual is intended to provide mechanical and electrical information for use in the planning and design of an installation of the Garmin G5 into an aircraft. This manual is not a substitute for an approved airframe-specific maintenance manual, installation design drawing, or complete installation data package. Attempting to install equipment by reference to this manual alone and without first planning or designing an installation specific to your aircraft may compromise your safety and is not recommended. The content of this manual assumes use by competent and qualified avionics engineering personnel and/or avionics installation specialists using standard aviation maintenance practices in accordance with Title 14 of the Code of Federal Regulations and other relevant accepted practices. This manual is not intended for use by individuals who do not possess the competencies and abilities set forth above.



NOTE

Garmin recommends installation of the G5 by a Garmin-authorized installer. To the extent allowable by law, Garmin will not be liable for damages resulting from improper or negligent installation of the G5. For questions, please contact Garmin Product Support at 1-888-606-5482.

1.2 G5 Overview

The G5 is an electronic instrument display capable of operating as a standalone flight display or a fully integrated backup instrument for G3X systems. It features a bright, sunlight readable, 3.5-inch color display which is sized to fit in a standard 3-1/8-inch instrument cutout. With integrated attitude/air data sensors and GPS, the G5 replaces traditional electromechanical standby instruments by combining essential information into one easy-to-read display. The G5 seamlessly integrates with other G5 units in the same aircraft and with G3X systems via the CAN network. When installed as part of a G3X system, the G5 provides a redundant source of attitude and air data to the G3X displays, and additionally provides backup autopilot control allowing coupled GPS approaches to be flown or continued in the event that the primary flight display is unavailable. When installed as a standalone system, the G5 can also perform the autopilot function. In the case of aircraft power loss, the optional battery backup sustains the G5 flight display with up to 4 hours of emergency power.



Figure 1-1 G5 Bezel Overview

1.3 Inventory of Materials

This manual provides (and provides references to) mechanical and electrical information required for the installation of the G5. This manual is intended to be a step-by-step guide to the installation, therefore it is important that the steps in all sections be performed in order. All materials that are required/optional for the installation of the G5 are listed in this section (as such, some of the information in this section is repeated in following sections).

Before beginning the G5 installation, it is recommended that the installer perform a complete inventory of all materials listed in this section (some materials are optional and may not be applicable to the installation). Section 1 should be used to verify that all components ordered from Garmin have been delivered correctly, and to identify any required materials that are not provided by Garmin.

1.4 Unpacking the Unit

Carefully unpack the equipment and make a visual inspection of all contents for evidence of damage incurred during shipment. If any component of the G5 is damaged, notify the carrier and file a claim. To justify a claim, save the original shipping container and all packing materials. Do not return any equipment to Garmin until the carrier has authorized the claim.

Retain the original shipping containers for storage. If the original containers are not available, a separate cardboard container should be prepared that is large enough to accommodate sufficient packing material to prevent movement.

1.5 Garmin Equipment

1.5.1 G5 Installation Equipment

Table 1-1 G5 Installation Equipment

LRU	Assembly Part Number	Unit Only Part Number
G5, Unit Only	010-01485-00	011-03809-00
Installation Kit, G5	010-12493-10	011-03892-00
Battery Pack, G5	010-12493-00	011-03893-00

1.5.2 Optional GPS Antenna

The G5 includes a built-in GPS receiver with an internal antenna that can be used in many installations. A Garmin or non-Garmin GPS antenna is optional for G5 installations when not using the G5's internal GPS antenna. See [Section 4](#) for supported antennas and antenna requirements.

1.5.2.1 Antenna Brackets/Doubler Plates

See the G3X/G3X Touch Installation Manual (190-01115-01) for detailed information.

1.5.3 Optional Garmin LRUs

The G5 can be installed in a standalone configuration or as part of the G3X system. Optional Garmin LRUs (Line Replaceable Units) that can be installed with the G5 in the standalone configuration are listed below. If any of these LRUs are to be used in this installation, verify that all required installation materials such as connector kits have been acquired. Refer to the G3X/G3X Touch Installation Manual (190-01115-01) available at <https://support.garmin.com/support/manuals> for additional installation information for these LRUs and for the G3X system.

Optional Garmin LRUs:

- GAD 29 ARINC 429 Adapter (required for connection to IFR Navigator)
- GMC 305 Mode Controller
- GMC 307 Mode Controller
- GMU 11 Magnetometer
- GSA 28 Autopilot Servo

1.6 Non-Garmin Equipment

1.6.1 Wiring/Cabling Considerations

The installer will provide all wiring and cabling unless otherwise noted.

1.6.2 Contact and Crimp Tools

Recommended crimp tools used to build the wiring harnesses for the G5 are listed in Table 1-2. Equivalent crimp tools may also be used.

Table 1-2 Pin Contact and Crimp Tools Part Numbers

Contact Type	Garmin Contact Part Number	Recommended Positioner	Recommended Insertion/Extraction Tool	Recommended Hand Crimping Tool
Socket, Size 20, 20-24 AWG	336-00022-02	M22520/2-08, Daniels K13-1	M81969/1-04 for size 22D pins and M81969/1-02 for size 20 pins	M22520/2-01, Daniels AFM8



NOTE

Non-Garmin part numbers shown are not maintained by Garmin and consequently are subject to change without notice.

1.6.3 BNC Connectors

BNC connectors may be required to terminate the GPS antenna cable, depending upon which antenna is used. Check the GPS antenna installation instructions for detailed information.

1.6.4 Hex Driver

A 3/32" hex drive tool is required to secure the G5 to the panel as described in [Section 3](#), G5 Installation.

1.6.5 SD Card

A microSD™ card can be used with the G5 for software updates and data logging. Garmin recommends SanDisk® brand SD cards up to 32 GB.

1.6.6 Pneumatic Hoses and Connectors

Air hoses and fittings are required to connect pitot and static air to the G5. The G5 has a female 1/8-27 ANPT fitting for each pitot and static port. Use appropriate aircraft fittings to connect to pitot and static system lines.

1.6.7 Silicone Fusion Tape

Use Garmin Part Number 249-00114-00 or similar to wrap the wiring/cable bundles.

1.7 Garmin Software and Documents

The G5 unit software and a panel cut-out DXF file are available for free download from <http://www8.garmin.com/support/collection.jsp?product=010-01485-00>.

2 INSTALLATION PREPARATION

This section provides electrical and mechanical information needed for planning the physical layout of the G5 installation. Use the information in Section 2 to become familiar with all aspects of the installation before actually beginning the physical installation of any equipment into the aircraft. Garmin recommends that the installer become familiar with all sections of this document before beginning the installation. In general terms, the below steps are recommended to be followed in order.

1. Inventory of all needed parts
2. Planning/layout of the installation
3. Installation of LRUs, antennas, and sensors
4. Construction of wiring harness, cables, and connectors
5. Software installation/configuration
6. Post-installation checkout procedure and calibration

2.1 Electrical Considerations

This section presents information required for planning the electrical layout of the G5 installation.



CAUTION

To avoid damage to the G5 and other LRUs, take precautions to prevent Electro-Static Discharge (ESD) when handling connectors and associated wiring. ESD damage can be prevented by touching an object that is of the same electrical potential as the LRU before handling the LRU itself.

2.1.1 Power Specifications

The G5 is capable of operating at either 14 or 28 VDC. Table 2-1 lists the supply voltage and current draw information for the G5. Use this information when determining power supply requirements. All installed electrical appliances must be considered when determining total power requirements.

The specified current draw listed in Table 2-1 is measured with the display backlight set to 100%.

Table 2-1 G5 Power Requirements

Configuration	14 V (Maximum)	14 V (Typical)	28 V (Maximum)	28 V (Typical)
G5 Only	3.5 W, 0.250 Amp	2.8 W, 0.200 Amp	3.5 W, 0.125 Amp	2.8 W, 0.100 Amp
G5 w/Battery	10.7 W, 0.760 Amp	2.8 W, 0.200 Amp	10.7 W, 0.380 Amp	2.8 W, 0.100 Amp

2.2 Wiring/Cabling Considerations

[Section 5](#) lists the pin information for the G5 and [Section 7](#) contains interconnect drawings. It is recommended that all LRUs be installed prior to constructing the wiring harnesses and cables.

Use MIL-W-22759/16 (or other approved wire) AWG #22 or larger wire for all non-shielded connections unless otherwise specified. Use MIL-C-27500 (or other approved wire) AWG #22 or larger wire for all shielded connections unless otherwise specified. The supplied standard pin contacts are compatible with up to AWG #20 wire. In cases where some installations have more than one LRU sharing a common circuit breaker, sizing and wire gauge is based on aircraft circuit breaker layout, length of wiring, current draw on units, and internal unit protection characteristics.

RG400 or RG142 coaxial cable with 50 Ω nominal impedance and meeting applicable aviation regulations should be used when installing an optional external GPS antenna.

2.2.1 Wiring Harness Installation

Use cable meeting the applicable aviation regulation for the interconnect wiring. Any cable meeting specifications is acceptable for the installation. When routing cables, observe the following precautions:

- All cable routing should be kept as short and as direct as possible.
- Check that there is ample space for the cabling and mating connectors.
- Avoid sharp bends in cabling.
- Avoid routing near aircraft control cables.
- Avoid routing cables near heat sources, RF sources, EMI interference sources, power sources (e.g. 400 Hz generators, trim motors, etc.) or near power for fluorescent lighting.
- Route the GPS antenna cable as far as possible away from all COM transceivers and other antenna cables.

The installer shall supply and fabricate all of the cables. Electrical connections are made through the D subminiature connector. [Section 5](#) defines the electrical characteristics of all input and output signals. Required connectors and associated hardware are supplied with the connector kit.

Contacts for the connectors must be crimped onto the individual wires of the aircraft wiring harness.

[Table 1-2](#) lists contact part numbers (for reference) and recommended crimp tools.



CAUTION

Check wiring connections for errors before connecting any wiring harnesses. Incorrect wiring could cause internal component damage.

2.2.2 CAN Bus Considerations

The primary digital interface used to exchange data between the G5 and other LRUs is the Controller Area Network, also known as the CAN bus. CAN was developed by Bosch GmbH in the 1980s, and its specifications are currently governed by ISO 11898-2. CAN is widely used in aviation, automotive, and industrial applications due to its simplicity and reliability.

2.2.3 CAN Bus Architecture

The electrical architecture of the CAN bus takes the form of a linear “backbone” consisting of a single twisted wire pair with an LRU connected (terminated) at each end (Figure 2-1). The overall length of the CAN bus from end to end should be 66 feet (20 meters) or less. At each of the two extreme ends of the CAN bus, a 120 Ω resistor is installed to “terminate” the bus. Termination resistors are provided either within the LRUs themselves, or via termination adapters that plug into an LRUs CAN connection (see [Section 2.2.5](#)).

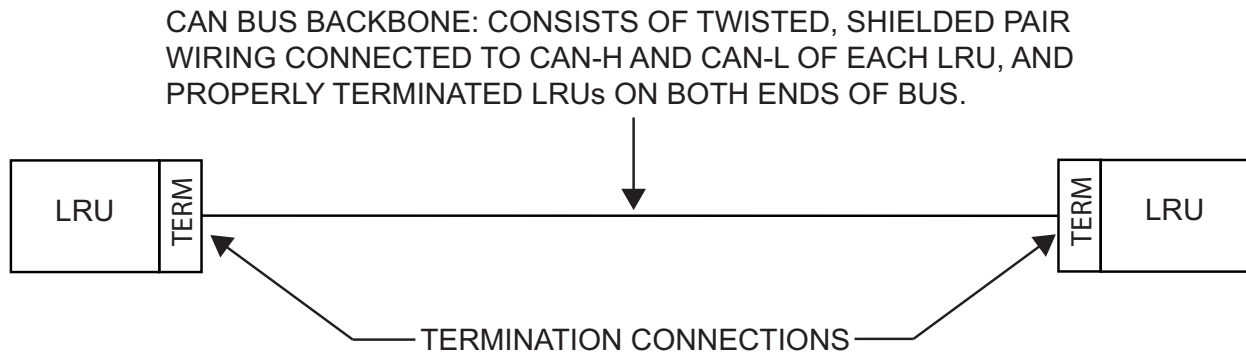

Figure 2-1 CAN Bus Backbone

Multiple LRU's may be connected in a daisy chain manner along the backbone of the CAN bus (Figure 2-2).

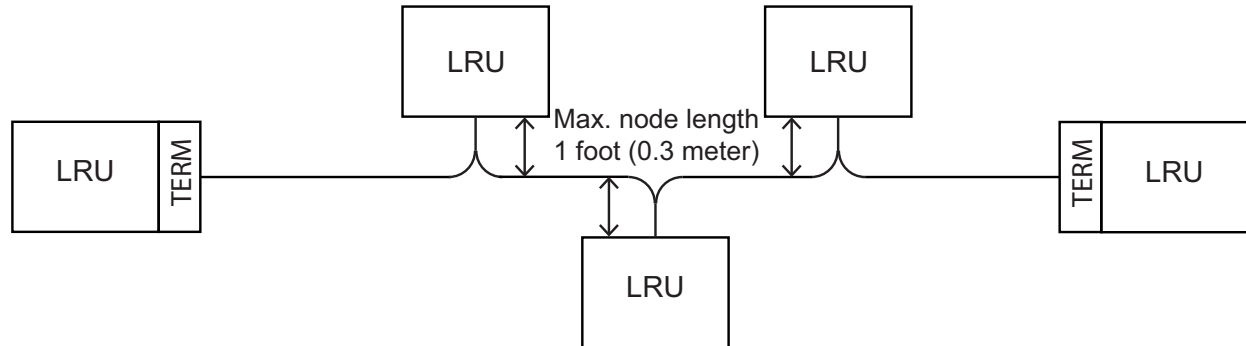
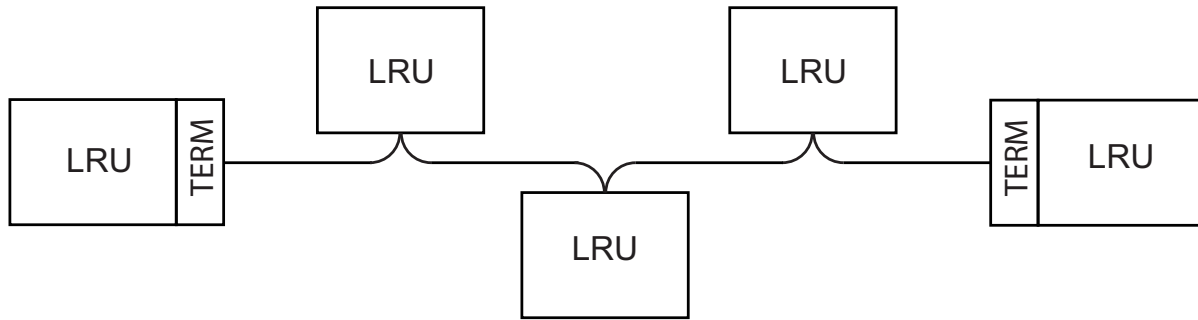

Figure 2-2 CAN Bus Node Connections

Daisy-chained LRUs (LRUs not at the extreme ends of the CAN bus) connect to the CAN backbone through short “stub” or “node” connections (Figure 2-3). The length of each node connection should be kept as short as possible, and should not exceed 1 foot (0.3 meter). The best way to connect devices between the ends of the CAN bus while maintaining short stub node lengths is to splice the connections as close to the device as practical. Unshielded wire sections should be kept as short as practical.

Multiple devices must not connect to the CAN bus backbone at the same point. Rather than splicing two or more stub node connections together, the CAN bus should instead be daisy-chained from one device to the next (Figure 2-3).



LINEAR CAN BACKBONE, DAISY-CHAINED CONNECTIONS WITH SHORT STUB NODE LENGTHS. MULTIPLE LRUs ARE NOT CONNECTED TO THE BACKBONE AT THE SAME LOCATION.

Figure 2-3 Correct CAN Wiring Example

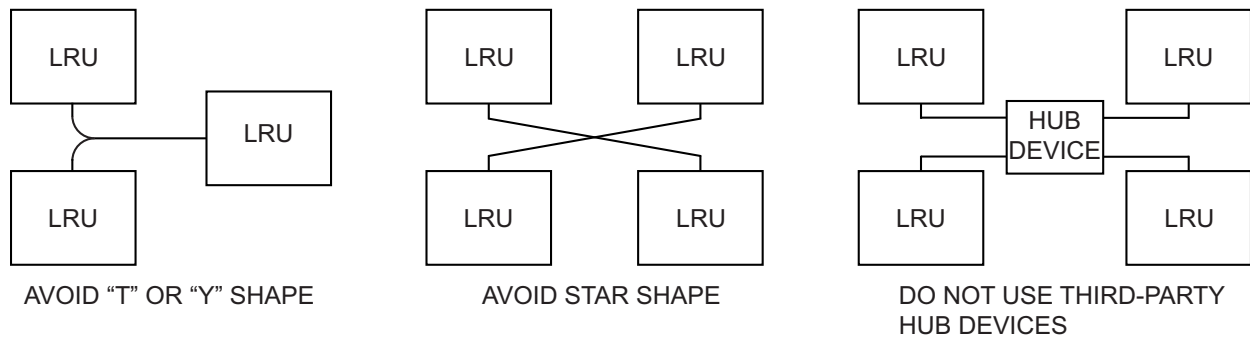
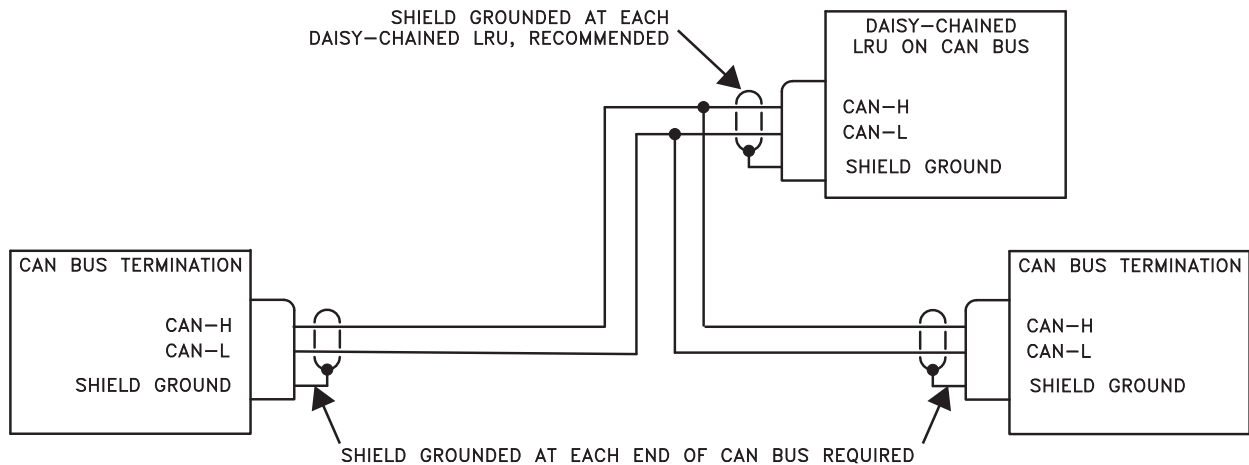

Figure 2-4 Incorrect CAN Wiring Example

2.2.4 CAN Bus Wiring

Wiring used for the CAN bus should be shielded twisted-pair cable, MIL-C-27500 or equivalent. 22 AWG or larger wire is recommended for physical robustness and ease of installation. The shields for each CAN bus wire segment should be interconnected, forming a continuously connected shield from one end of the CAN bus to the other (Figure 2-5). At a minimum, the CAN bus shield should always be grounded to the device connector backshells at the two extreme ends of the bus, but it is recommended to also ground the shield at all other devices on the CAN bus.



CAN-H AND CAN-L WIRING SHOWN IS TWISTED SHIELDED PAIR

Figure 2-5 CAN Bus Shield Grounding

For proper CAN bus operation, it is important for all devices on the CAN bus to share a common power ground reference. Connect all LRU power ground pins to a single common ground point - do not use local ground points or use the aircraft structure as a ground return path.

2.2.5 CAN Bus Termination

At each of the two extreme ends of the CAN bus backbone, a 120 Ω resistor is installed to terminate the bus. Separate resistors are not required, termination resistors are provided either within the LRUs themselves, or via termination adapters that plug into an LRU’s CAN connection.

- The GAD 29, GMU 11, GPS 20A, and G5 installation kits each provide a 9-pin termination adapter that provides CAN bus termination when attached between the LRU and the cable assembly. The termination adapter contains a 120 Ω resistor that is connected between pins 1 and 2 (Figure 2-6).
- The GSA 28 contains a 120 Ω resistor inside the unit that provides termination when the two CAN-TERM pins are connected together (Figure 2-7).

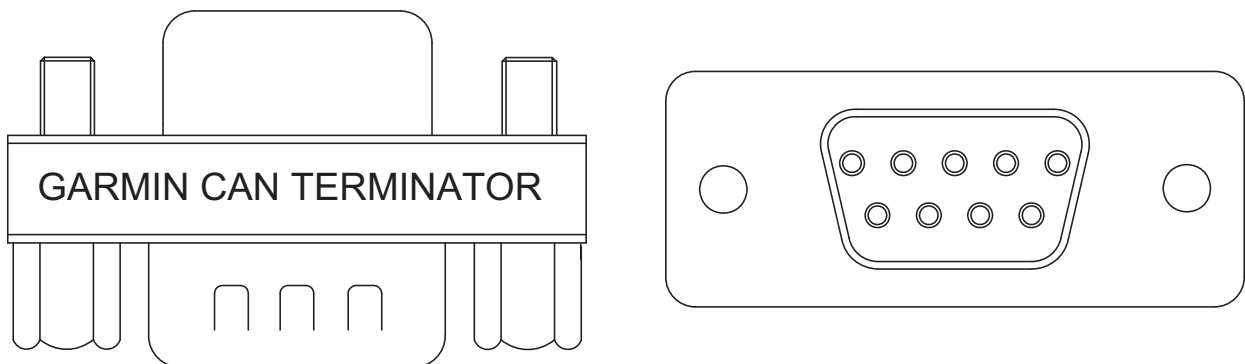

Figure 2-6 CAN Bus Termination (011-02887-00) for the G5, GAD 29, GMU 11, and GPS 20A

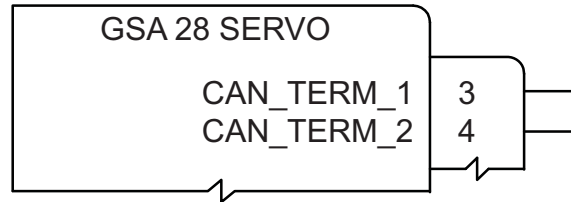
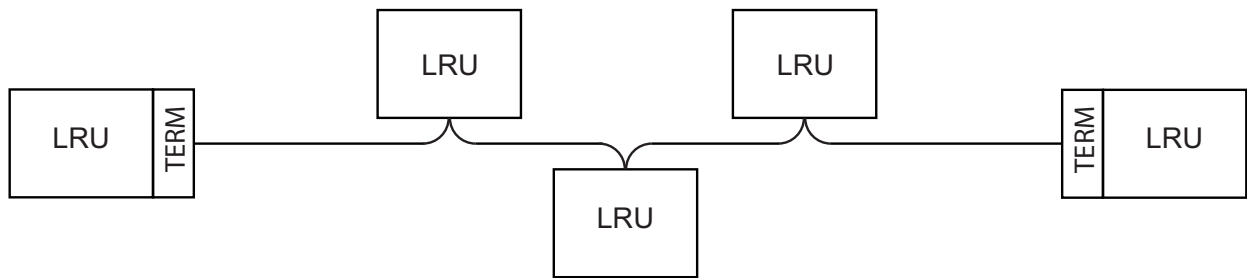

Figure 2-7 CAN Bus Termination for the GSA 28

Both ends of the CAN bus should be terminated (Figure 2-8) and devices that are not at the ends of the CAN bus should not be terminated (Figure 2-9).



CORRECT - CAN BUS TERMINATED AT EACH END OF THE BACKBONE

Figure 2-8 Correct CAN Bus Termination Example

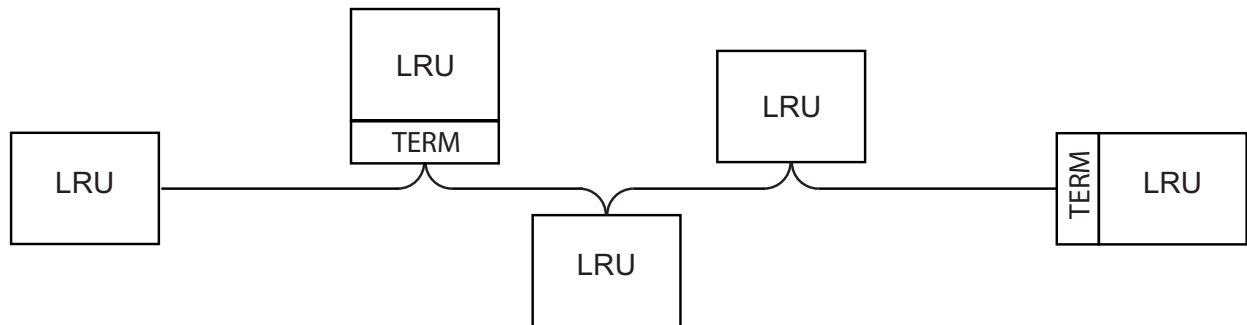

INCORRECT - ONE OF THE TERMINATIONS IS NOT AT THE END OF THE BACKBONE

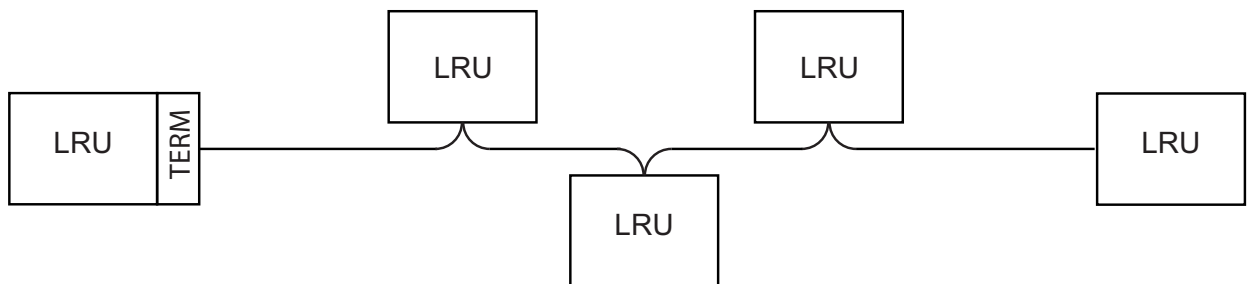

INCORRECT - ONLY ONE END OF THE BACKBONE IS TERMINATED

Figure 2-9 Incorrect CAN Bus Termination Example

2.2.6 CAN Bus LRU Removal Guidelines

The following should be considered when removing an LRU from the ends of the CAN bus.

- GAD 29, GMU 11, GPS 20A, G5, or other devices that use the 9-pin CAN termination adapter: The CAN bus will remain terminated as long as the CAN termination adapter is left connected to the cable assembly.
- GSA 28: A removal adapter (part number 011-03158-00) is provided with each GSA 28 connector kit. This adapter can be used when a GSA 28 is removed from the aircraft. The removal adapter keeps the node on the CAN bus in the same state as when the servo was installed (either terminated or un-terminated). The removal adapter also allows trim signals to pass through when no servo is installed.

2.2.7 CAN Bus Installation Guidelines

For maximum reliability of the CAN bus, the following guidelines should be followed:

- The CAN bus backbone must be a single linear path with exactly two distinct ends. CAN bus connections should be daisy-chained from device to device. Avoid “T”, “Y”, and "star" topologies, and do not use a hub device ([Figure 2-4](#)).
- The overall length of the bus should not exceed 66 feet (20 meters).
- Keep all stub node connections as short as practical. The maximum length of any stub node connection is 1 foot (0.3 meter).
- Avoid connecting more than one device to the CAN bus backbone at the same point. Instead, daisy chain the CAN bus backbone from one device to the next.
- Observe proper wiring, shielding, and grounding requirements described in [Section 2.2.2](#).
- Terminate the CAN bus at the two extreme ends of the bus, as described in [Section 2.2.3](#).
- When adding a new device to the CAN bus, evaluate proposed modifications to the CAN bus wiring connections to ensure compliance with all of the preceding requirements.

2.2.8 CAN Bus Troubleshooting

The CAN bus is very simple, and a properly installed CAN bus is very reliable. If problems are occurring, the following steps can help to identify the issue.

1. Review the status LED of devices on the CAN bus such as the GSA 28 servos. The status LED indications are listed in Section 2-2.

Table 2-2 Status LED Indications

LED Indication	Description
No Light	No power
Steady Green	On but not communicating via CAN bus
Flashing Green	On and communicating via CAN bus
Red	Hardware fault
Alternating Red/Green	CAN bus network error (two identical LRUs are configured with the same unit ID)

2. Make sure that the CAN bus is daisy-chained between CAN devices around the system, and that CAN devices are not connected via a single point (star topology) or routed through a hub device. This can cause unwanted signal reflections and “orphan” some devices on the bus and prevent their communication.

3. Make sure the CAN bus is terminated in only two locations, and only at the extreme ends of the CAN bus.
4. With power removed, remove the CAN bus connector from one of the devices that is not located at either of the extreme ends of the CAN bus.
 - a) Using an ohm meter, verify that the resistance between the CAN-H and CAN-L pins on the connector is 60 Ω . This will verify that the CAN backbone is properly terminated at each end (two 120 Ω terminating resistors in parallel).
 - b) A resistance of 120 Ω indicates that one of the two required CAN terminations is missing.
 - c) A resistance of 40 Ω or less indicates that too many terminations are installed.
5. Verify that the CAN-H and CAN-L signals are not swapped, shorted together, or open-circuited at any LRU connector.
6. Verify that the CAN-H and CAN-L signals are not shorted to ground (this can happen when shielded wire is installed incorrectly).
7. Highlight each device on the configuration mode Device Information page and verify that the value displayed for Network Error Rate is a steady 0%.

ARINC 429 Interface Information	
Product Name	GAD 29
Software Version	2.30
Network Error Rate	✓ 0%
Serial Number	366000561

Figure 2-10 Network Error Rate

8. Power up only the #1 G5 unit and one other CAN device at a time, and verify the connection quality for each device. Sometimes a device will communicate only when it is the only powered device on the CAN bus, if one or more of the above issues is present. Evaluating each CAN device in turn can help narrow down a problem.
9. It is very important for each device on the CAN bus to share a common power/signal ground. Ground potential differences between devices on the CAN bus can cause communication errors. Ground devices to a common ground bus, not to the airframe or to multiple grounding buses.

10. Advanced CAN diagnostics are available by selecting Device Information, Diagnostics, CAN Network. Any increase of these parameters above zero is an indication of a CAN bus issue.



Figure 2-11 CAN Diagnostic Page

2.2.9 Cable Connector Installation

A coaxial cable connection is required for the optional external GPS antenna.

1. Route the coaxial cable to the unit location. Secure the cable in accordance with good aviation practices.
2. Trim the coaxial cable to the desired length and install the BNC connector. If provided, follow the connector manufacturer's instructions for cable preparation.

2.3 Mechanical Considerations

This section presents all information required for planning the physical layout of the G5 installation.

2.3.1 Physical Specifications

Use Table 2-3 to determine panel requirements. All width, height, and depth measurements are taken with unit mounting ring and connectors (if applicable).

Table 2-3 G5 Physical Specifications

Configuration	Width	Height	Depth*	Unit Weight	Weight of Unit and Connector**
G5	3.42 in	3.60 in	2.61 in	0.55 lb	0.70 lb
G5 with Battery	3.42 in	3.60 in	3.03 in	0.83 lb	0.98 lb

*Depth behind aircraft panel

**Weight includes mounting ring

2.3.2 Cooling Requirements

While no forced cooling air is required for the G5, it is highly recommended that the air behind the panel be kept moving (by ventilation or a fan). Units tightly packed in the avionics stack heat each other through radiation, convection, and sometimes by direct conduction. Even a single unit operates at a much higher temperature in still air than in moving air. Fans or some other means of moving the air around electronic equipment are usually a worthwhile investment.



NOTE

Avoid installing LRUs near heat sources. If this is not possible, ensure that additional cooling is provided. Allow adequate space for installation of cables and connectors. The installer will supply and fabricate all of the cables. All wiring should be in accordance with FAA AC 43.13-1B and AC 43.13-2B.

2.3.3 Compass Safe Distance

After reconfiguring the avionics in the cockpit panel, if the unit is mounted less than 12 inches from the compass, recalibrate the compass and make the necessary changes for noting correction data.

3 G5 INSTALLATION

The G5 can be installed as a standalone flight display or a fully integrated backup instrument in the G3X system. This section contains general information as well as installation information for the G5.

3.1 Primary Functions

- Attitude (roll, pitch, and yaw)
- Air data (altitude and airspeed)
- Slip/skid and turn coordinator
- GPS (ground speed and ground track)
- Autopilot control (when installed with optional equipment)
- Optional battery backup with up to 4 hours of emergency power
- RS-232 and CAN communication interfaces
- Course and navigation display (when installed with optional equipment)
- Magnetic heading (when installed with optional equipment)

3.2 General Specifications

See [Section 2.1.1](#) for power/current specifications, and [Section 2.3.1](#) for dimension/weight specifications.

3.3 Installation Information

3.3.1 Required Equipment

One installation kit (Section 3-1) is required to install each G5 unit. The G5 Mounting Ring is included in the installation kit to mount the G5 to the aircraft panel and to reinforce the panel cutout in thin panel installations. The installation kit is not included with the G5.

Table 3-1 Contents of the G5 Installation Kit (011-03892-00)

Item	Garmin P/N	Quantity
Connector Kit, 9 Pin, w/CAN Term	011-03002-00	1
Mounting Ring, G5	115-02251-03	1
Screw, 6-32, 0.500"	211-60207-12	3

Table 3-2 Contents of the Connector Kit (011-03002-00)

Item	Garmin P/N	Quantity
Sub-Assy, Bkshl w/Hdw, Jackscrew, 9 pin	011-01855-00	1
Sub Assy, CAN Termination Kit	011-02887-00	1
Conn, Rcpt, D-Sub, Crimp Socket, 9 Ckt	330-00625-09	1
Contact, Sckt, D-Sub, Crimp, Size 20, 20-24 AWG	336-00022-02	9

3.3.2 Additional Equipment Required

A 3/32" hex drive tool is required to secure the G5 to the panel as described in [Section 3.6.3](#) and shown in [Figure 3-4](#).

Air hoses and fittings are required to connect pitot air and static air to the G5. The G5 uses a female 1/8-27 ANPT fitting for each of these ports. Use appropriate aircraft fittings to connect to pitot and static system lines.

3.4 Unit Installation

Fabrication of a wiring harness is required. Sound mechanical and electrical methods and practices are recommended for installation of the G5. Refer to [Section 2.2](#) for wiring considerations, and to [Section 5](#) for pinouts.

Connector kits include backshell assemblies. Garmin's backshell connectors give the installer the ability to quickly and easily terminate shield grounds at the backshell housing. Instructions needed to install the Jackscrew Backshell and Shield Block Ground can be found in [Section 6](#).

3.4.1 Mounting Requirements

The G5 includes an extremely sensitive inertial measurement unit. Consider the following when selecting a mounting location:

- Mount the G5 with the connector aligned to within 1.0° of the longitudinal axis of the aircraft (display bezel parallel to the wing spar). Do not install the G5 in a panel that is angled to the left or right with respect to the wing spar.
- The G5 should be rigidly mounted to the aircraft panel. To avoid degraded accuracy, the aircraft panel should be rigid and panel flexing should be minimized.
- The G5 should be mounted to the aircraft panel with the connector facing toward the front of the aircraft.
- The G5 should be mounted within 13 feet (4 meters) longitudinally of the aircraft CG (center of gravity). In cases where the longitudinal distance from the CG is planned to be greater than 6.5 feet (2 meters), it is preferable to mount the G5 forward of the aircraft CG, if possible, to improve autopilot performance.
- To prevent degraded accuracy, avoid placing the G5 near areas that are prone to severe vibration.
- The G5 must be leveled to within 30.0° of the flight level cruise attitude. An aircraft leveling and offset calibration procedure must additionally be carried out prior to flight.
- The mounting location for the G5 should be protected from rapid thermal transients, in particular large heat loads from nearby high-power equipment.
- Avoid placing the G5 within 1 inch of magnetically mounted antennas, speaker magnets, or other strongly magnetic items.

3.4.2 Unit Mounting

For final installation and assembly, refer to the outline and installation drawings in [Section 3.7](#).

1. Mount the G5 in a suitable location using the installation kit ([Table 3-1](#)) per the requirements in Section 3.4.1.
2. Assemble the wiring harness and backshell connector.
3. Assemble the pneumatic hoses and connector.
4. Connect the CAN terminator if required (see [Section 2.2.5](#)).
5. Connect the backshell connector and hoses.

3.4.3 Pneumatic Plumbing

The G5 has two ports that are connected to the aircraft's pitot and static pressure sources. The ports are labeled on the unit using the abbreviations "P" and "S" respectively (Figure 3-1). The pressure ports have 1/8-27 ANPT female threads. The mating fitting must have 1/8-27 ANPT male threads.



NOTE

The temporary port plugs attached to the pressure ports on a new G5 are not suitable for flight and must be removed prior to the installation of G5 into the aircraft.



NOTE

In an installation with dual G5 units, pitot/static plumbing must be connected to both units.

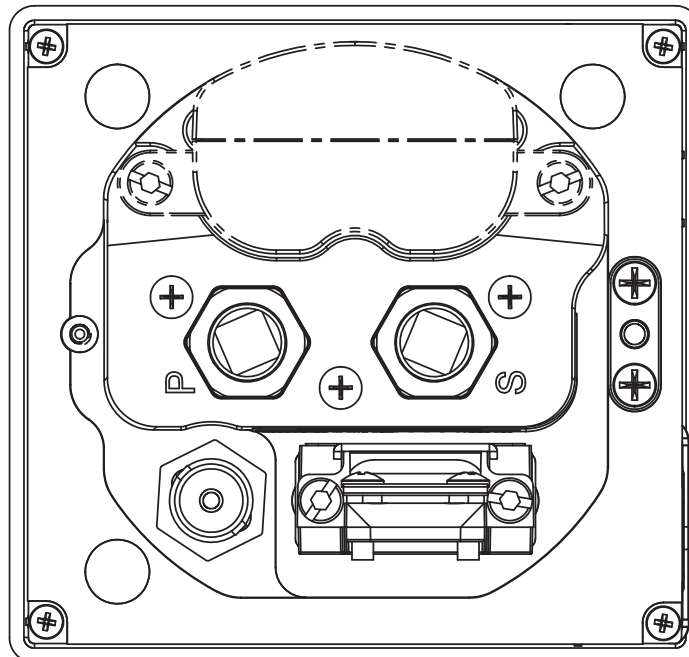

Figure 3-1 G5 Air Hose Fitting Locations

Use appropriate air hoses and fittings to connect the pitot and static lines to the unit. Avoid sharp bends in the tubing and attempt to route hoses away from aircraft control cables. The G5 should not be at the low point of the pneumatic plumbing lines to avoid moisture or debris collecting at or near the unit. Ensure that no deformations of the airframe surface have been made that would affect the relationship between static air pressure and true ambient static air pressure for any flight condition. Refer to CFR Part 43, Appendix E for approved practices while installing hoses and connections.



NOTE

A G5 installed as a standalone unit may optionally be configured to disable its internal air data sensors. In this case, no connection to the aircraft's pitot/static system is required. If not connected, the pitot/static fittings on the G5 should be covered with dust caps. A G5 with air data disabled does not support autopilot functionality.

3.4.4 Pneumatic Connections

The following steps should be used to aid in the fabrication of pneumatic hose connections and in attaching the aircraft pitot pressure source and aircraft static pressure sources to the G5.



NOTE

Whenever the aircraft is connected to a pitot-static tester, such as during Part 43 Appendix E altimeter tests, the pitot port must be covered by a pitot adapter that is controlled by the pitot-static tester. Failure to do so will result in overpressuring and damaging the internal airspeed sensor.



NOTE

Use of different colored tubing is recommended for static and pitot plumbing to avoid plumbing connection errors. Incorrect plumbing connections will result in erroneous air data information calculated by the G5.

Observe the following cautions when connecting pneumatic lines:

1. Make sure the aircraft static pressure port is plumbed directly to the unit static pressure input port and the aircraft pitot pressure port is plumbed directly to the unit pitot pressure input port.
2. Seal the threads of pneumatic fittings at the connector ports. Use caution to ensure there are no pneumatic leaks.
3. Use care to avoid getting fluids or particles anywhere within the pneumatic lines connected to the G5.

3.5 Antennas

Refer to [Section 4](#) for antenna installation information.

3.6 Mounting Instructions

Refer to [Section 3.7](#) for outline and installation drawings.



NOTE

In addition to the mounting requirements listed in [Section 3.4.1](#), it is critical that the G5 be installed with its display bezel perpendicular to the aircraft's longitudinal axis (display bezel parallel to the wing spar) and as close to level in the roll axis as possible. Small roll offsets, and pitch offsets up to 30°, can be corrected for during calibration.

3.6.1 Panel Cutout Template

The G5 Mounting Ring (115-02251-03) or [Figure 3-9](#) can be used as a template when marking the panel for cutout. See [Figure 3-8](#) for complete cutout dimensions (the dimensions on [Figure 3-8](#) are to verify the accuracy of the printout only).

3.6.2 Mounting Ring Installation

Secure the mounting ring to the aircraft panel using the supplied #6-32 pan head Phillips mounting screws. Evenly torque the mounting screws to 10-12 in-lb.

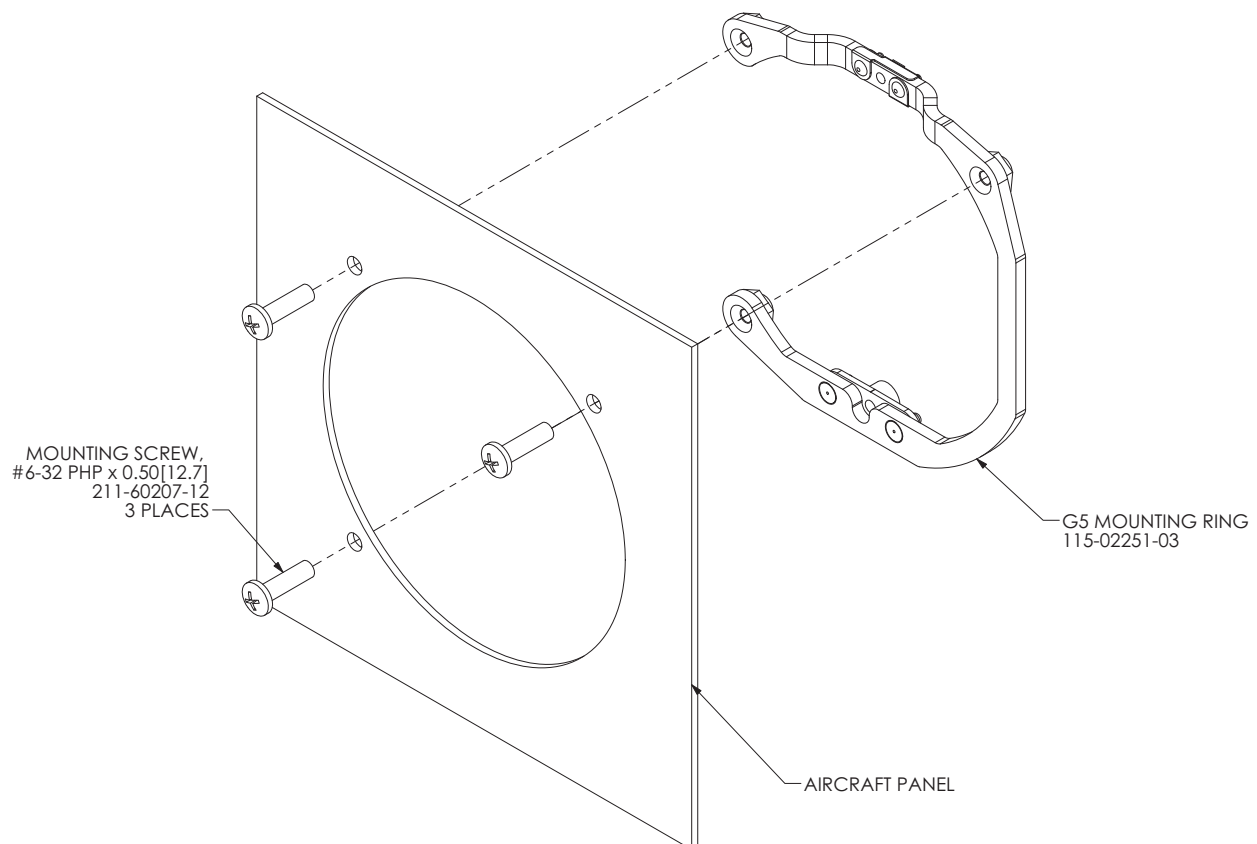

Figure 3-2 G5 Mounting Ring

3.6.3 Unit Installation

The G5 is installed by inserting the alignment pin located at the top of the unit into the mating hole in the mounting ring, pushing the unit flush with the instrument panel, and fastening the captive 3/32" hex socket head screw to the mounting ring as shown in [Figure 3-3](#). To fasten the captive screw to the mounting ring, insert a 3/32" hex drive tool through the access hole in the front cover of the G5 as shown in [Figure 3-4](#). Torque the captive mounting screw to 10-12 in-lb.

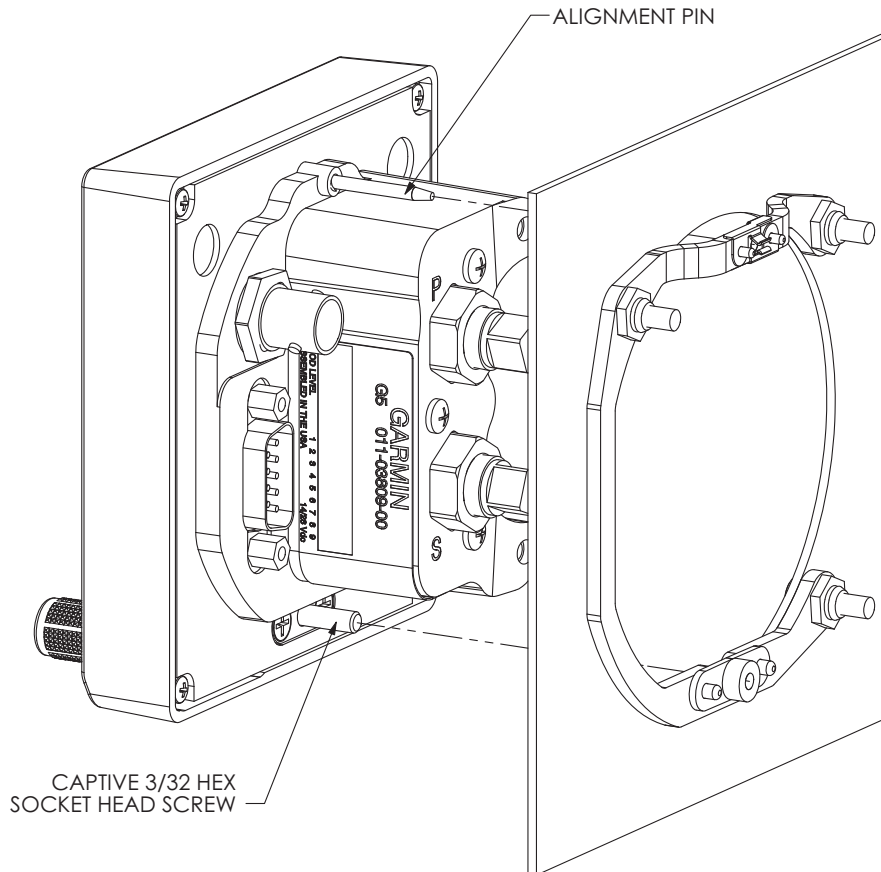

Figure 3-3 G5 Alignment Pin

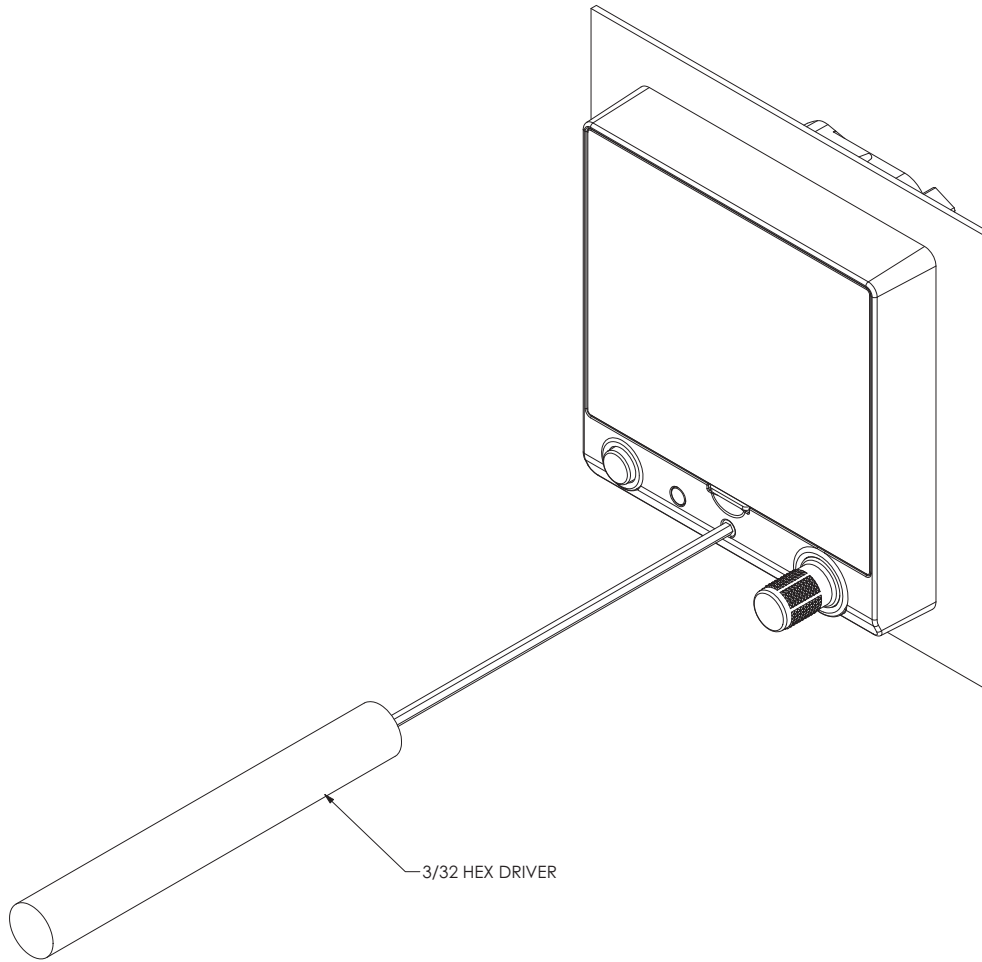

Figure 3-4 G5 Hex Driver Insertion

3.6.4 Captive Mounting Screw Replacement

The captive 3/32" hex socket head screw can be used for panel thicknesses up to 0.150 inch. For installations with a panel thickness greater than 0.150 inch, the captive mounting screw can be replaced with a standard #6-32 hex socket head screw. To replace the screw, remove the two #4-40 flat head Phillips mount plate screws, the G5 screw mount plate, and the captive screw as shown in [Figure 3-5](#). Reverse this process to install the longer #6-32 hex socket head screw. Ensure correct orientation of the screw mount plate before applying 6-8 in-lb of torque to the #4-40 mount plate screws.



NOTE

Standard #6-32 hex socket head screws use a 7/64" hex drive feature. The access hole in the G5 bezel is large enough to accommodate this increase in hex tool size.

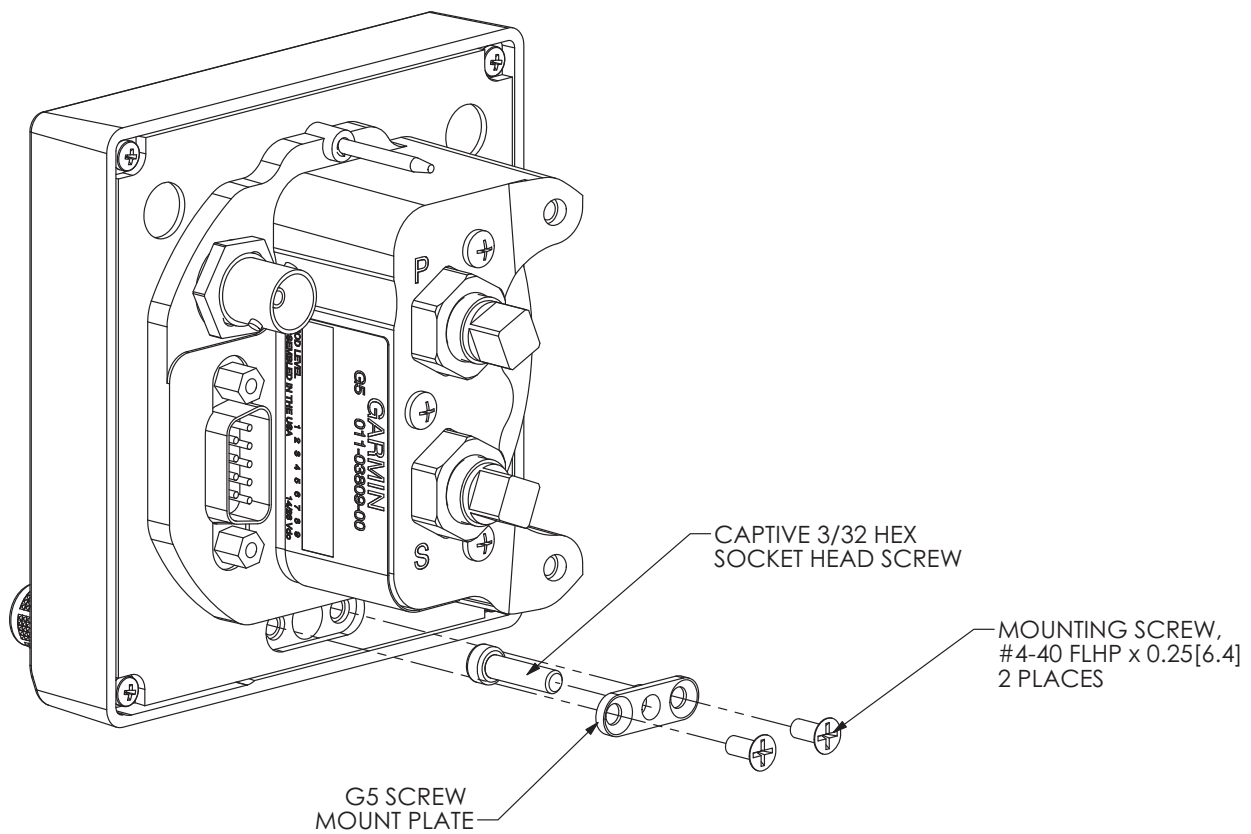
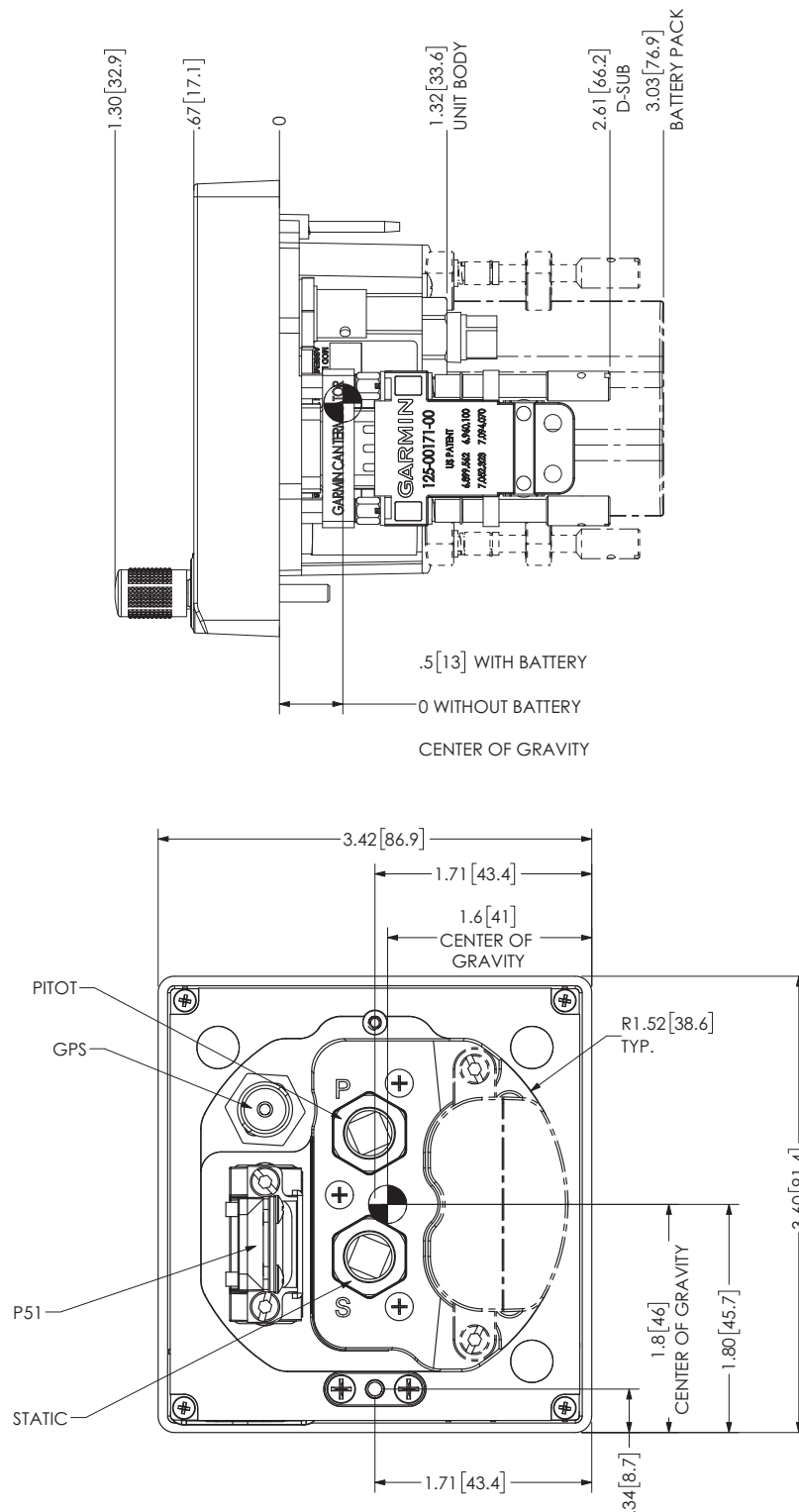

Figure 3-5 G5 Mounting Screw Replacement

3.7 Outline and Installation Drawings



NOTES:
 1-1. DIMENSIONS: INCHES [mm]. METRIC VALUES ARE FOR REFERENCE ONLY.
 1-2. DIMENSIONS ARE NOMINAL AND TOLERANCES

Figure 3-6 G5 Outline Drawing

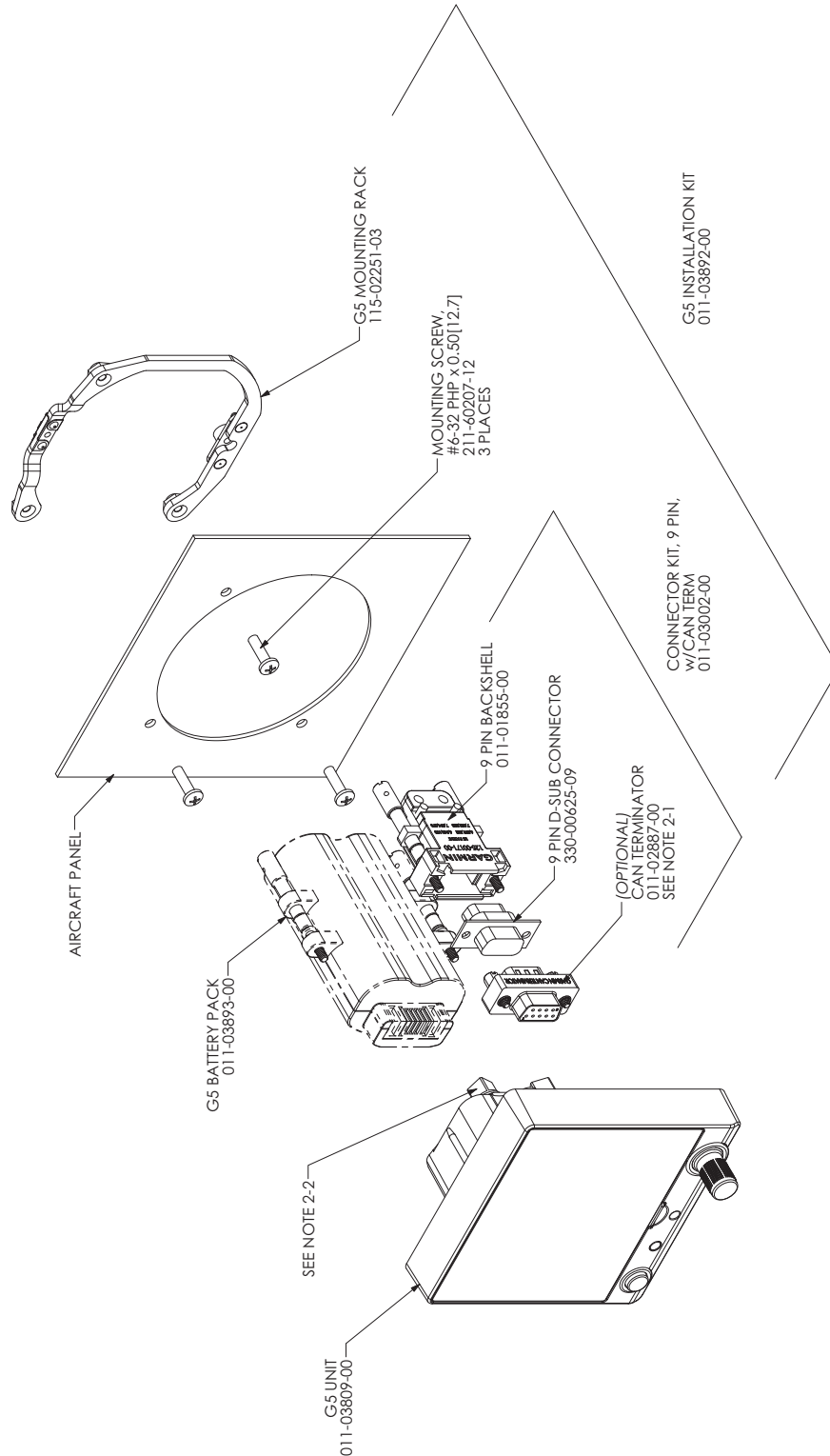

- NOTES:
- 2-1. DEPENDING ON HOW THE SYSTEM IS PHYSICALLY WIRED, THIS TERMINATOR MAY OR MAY NOT BE NEEDED IN THE INSTALLATION. THE CAN BUS MUST BE TERMINATED AT ONLY THE TWO MOST EXTREME POINTS ON THE CAN BACKBONE. IF USED WITH THE G3X SYSTEM REFER TO THE G3X INSTALL MANUAL FOR SPECIFIC GUIDANCE ON CAN BUS WIRING.
 - 2-2. ALL RED PLUGS MUST BE REMOVED AND DISCARDED. THEY ARE NOT TO BE USED FOR CAPPING AND SEALING UNUSED PORTS.

Figure 3-7 G5 Installation Drawing

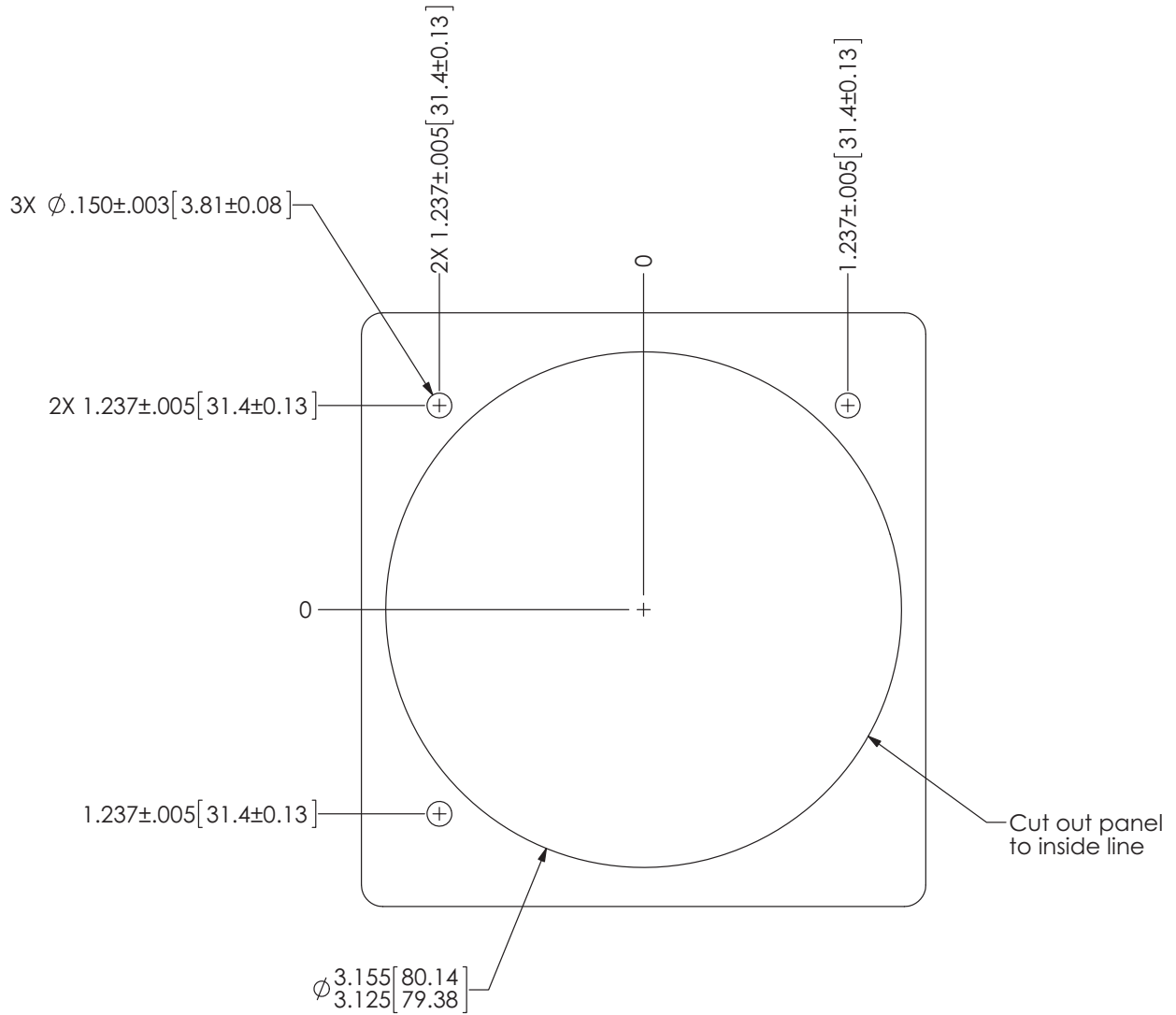
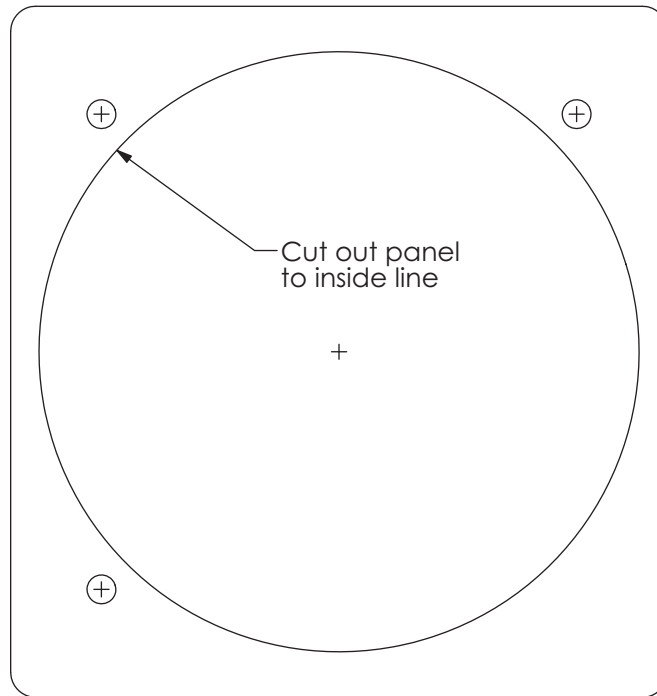

Figure 3-8 G5 Panel Cutout Measurements (Not to Scale)



IMPORTANT!

Ensure the Page Scaling setting is set to NONE when printing this page. Verify dimensions of printed template are accurate before cutting panel.

For mounting holes, drill out with #25 drill bit and use Garmin mounting rack P/N 115-02251-03.

For panel cutout, drill out with a 3.125" diameter bimetal hole saw.

The outline in this drawing is identical to the outline of the actual bezel.

Figure 3-9 G5 Panel Cutout Drawing (Template)

4 GPS ANTENNA INSTALLATION

This section contains general information as well as installation information for GPS antennas. Garmin recommends the antennas shown in Table 4-2. However, any equivalent antenna that meets the specifications listed in Table will work with the G5.

The G5 can receive GPS position information using the unit's internal antenna or by connecting an external antenna. It is recommended to verify the ability of the G5 to receive GPS information via the unit's internal antenna as GPS reception quality is dependent upon the installation. The G5 will share GPS information with any connected GDU 37X/4XX.

The G5 can additionally receive GPS position information from a GPS 20A or GDU 37X/4XX. A minimum of one GPS antenna is required for G5 installations receiving GPS information from another LRU. Additional GPS antennas may be used for redundancy, but are not required.

A GPS 20A (and connected GPS/WAAS antenna) can be used as the sole GPS source for a G5 system, however it is recommended to also install a GPS antenna on a G5 or GDU 37X/4XX for redundancy. If the G5's GPS receiver is not used in a particular installation, it may be disabled in configuration mode (see [Section 8.4.13](#)).

4.1 Non-Garmin Antennas

Table 4-1 lists non-Garmin antennas currently supported by the G5. For non-Garmin antennas, follow the manufacturer's installation instructions. It is the installer's responsibility to ensure that their choice of antenna meets FAA standards according to the specific installation.

Table 4-1 Supported Non-Garmin Antennas

Model	Mount Style	Conn Type	Antenna Type	Mfr	Antenna Part Number	Garmin Order Number
Comant 2480-201 VHF/GPS*	Screw Mount, Teardrop Footprint	BNC/TNC*	VHF COM/ GPS	Comant	CI 2480-201	N/A

*The GPS antenna connector is TNC type. The VHF COM antenna connector is BNC type.

4.2 Garmin Antennas



NOTE

See the G3X/G3X Touch Installation Manual (190-01115-01) for detailed GPS antenna installation information. All antenna mounting and unit installation recommendations applicable to the GDU37X/4XX also apply to the G5.



NOTE

It is the installer's responsibility to ensure that their choice of antenna meets FAA standards according to the specific installation.

Table 4-2 Supported Garmin Antennas

Model	Part Number	Install Manual	Mounting Configuration
GA 26C (GPS)	011-00149-04	190-00082-00	Flange, Magnetic, or Suction Cup Mounts (in-cabin)
GA 35 (GPS/WAAS)	013-00235-0X	190-00848-00	Thru-Mount (tear drop form factor)
GA 36 (GPS/WAAS)	013-00244-0X	190-00848-00	Thru-Mount (ARINC 743 form factor)
GA 56 (GPS)	011-00134-00	190-00094-00	Stud Mount (tear drop form factor)
GA 57X (GPS/XM)	011-01032-10	190-00522-02	Thru-Mount (ARINC 743 form factor)

Table 4-3 GPS Antenna Minimum Requirements

Characteristic	Specification
Frequency Range	1565 to 1585 MHz
Gain	16 to 25 dB typical, 40 dB max
Noise Figure	Less than 4.00 dB
Nominal Output Impedance	50 Ω
Supply Voltage	4.5 to 6.5 VDC
Supply Current	up to 60 mA

5 G5 PINOUT

Use the information in this section (along with other applicable sections in this document) to construct the wiring required for the G5 installation.

Connector references used throughout this document use the prefixes "J" (Jack) and "P" (Plug). "J" refers to the the connector on the LRU, and "P" refers to the connector on the wiring harness. "J" and "P" designate the connector only, regardless of the contact type (pin or socket).

5.1 J51 Connector

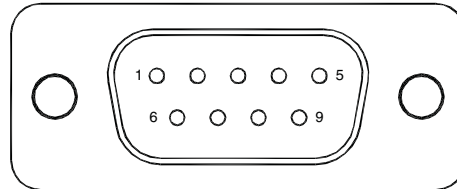

Figure 5-1 J51 Connector on the G5

Table 5-1 J51 Pin Descriptions

Pin	Pin Name	I/O
1	CAN-H	I/O
2	CAN-L	I/O
3	UNIT ID	In
4	RS-232 RX 1	In
5	RS-232 TX 1	Out
6	SIGNAL GROUND	--
7	AIRCRAFT POWER 1	In
8	AIRCRAFT POWER 2	In
9	POWER GROUND	--

5.1.1 Aircraft Power

The G5 can operate using power from one or both inputs (AIRCRAFT POWER 1 and AIRCRAFT POWER 2). The pins are internally connected using diodes to prevent current from flowing between the two power inputs. AIRCRAFT POWER 2 is for connecting to an alternate power source, such as on aircraft with two electrical buses.

5.1.2 RS-232

The G5 has one RS-232 channel that may be used to output and/or receive data from another device. Refer to [Section 8.4.13.4](#) for detailed information.

5.1.3 CAN Bus

The G5 CAN bus conforms to the BOSCH standard for Controller Area Network 2.0-B and ISO 11898. See [Section 2.2.2](#) for details. The CAN bus connection on the G5 can be used for the following:

- Connection to the G3X system
- G5/G5 interconnect (non-G3X system)
- G5/GSA 28 interconnect (non-G3X system)
- G5/GAD 29 interconnect (non-G3X system)
- G5/GMU 11 interconnect (non-G3X system)

5.1.4 Unit ID

The G5 detects its assigned unit type at startup by checking the UNIT ID pin. This pin can be strapped into the following configurations. A maximum of two G5 units may be used in a single installation.

Table 5-2 Unit ID Configurations

Unit ID	Comment
G5 #1	Leave pin 3 unconnected
G5 #2	Ground pin 3 to pin 6 or pin 9

6 CONNECTOR INSTALLATION INSTRUCTIONS

6.1 Shield Block Installation Parts

Table 6-1 and Table 6-2 list the parts needed to install a Shield Block. The item numbers in these tables correspond to the example drawing in [Figure 6-1](#). The parts listed in Table 6-1 are supplied in the G5 installation kit. The parts listed in Table 6-2 are to be provided by the installer as required.

Table 6-1 Garmin Supplied Shield Block Installation Parts for the G5

Item #	Description	GPN or MIL Spec
1	Backshell, Jackscrew, 9 pin	125-00171-00
6	Contact, Sckt, D-Sub, Crimp, Size 20, 20-24 AWG	336-00022-02
12	Clamp, Backshell, Jackscrew, 9 pin	115-01078-00
13	Screw, 4-40, 0.375"	211-60234-10
14	Cover, Backshell, Jackscrew, 9 pin	115-01079-00
15	Screw, 4-40, 0.187"	211-63234-06

Table 6-2 Installer Supplied Shield Block Installation Parts for the G5

Item #	Description	GPN or MIL Spec
2	Multiple Conductor Shielded Cable	Parts used depend on method chosen
3	Drain Wire Shield Termination (optional)	
4	Braid, Flat, 19-20 AWG Equivalent, Tin-plated Copper Strands, 36 AWG, Circular Mil Area 1000-1300	
5	Floating Shield Termination (optional)	
7	Ring terminal, #8, insulated, 18-22 AWG	
7	Ring terminal, #8, insulated, 14-16 AWG	MS25036-149
	Ring terminal, #8, insulated, 10-12 AWG	MS25036-153
		MS25036-156
8	Screw, 8-32, 0.312", PHP, Stainless	MS51957-42
	Screw, 8-32, 0.312", PHP, Cad-plated Steel	MS35206-242
9	Split Washer, #8, 0.045" Compressed Thickness, Stainless	MS35338-137
	Split Washer, #8, 0.045" Compressed Thickness, Cad-plated Steel	MS35338-42
10	Flat Washer, Stainless, #8, 0.032" Thick, 0.174" ID, 0.375" OD	NAS1149CN832R
	Flat washer, Cad-plated Steel, #8, 0.032" Thick, 0.174" ID, 0.375" OD	NAS1149FN832P
11	Silicone Fusion Tape	249-00114-00



NOTE

In Figure 6-1, "AR" denotes quantity "As Required" for the particular installation.

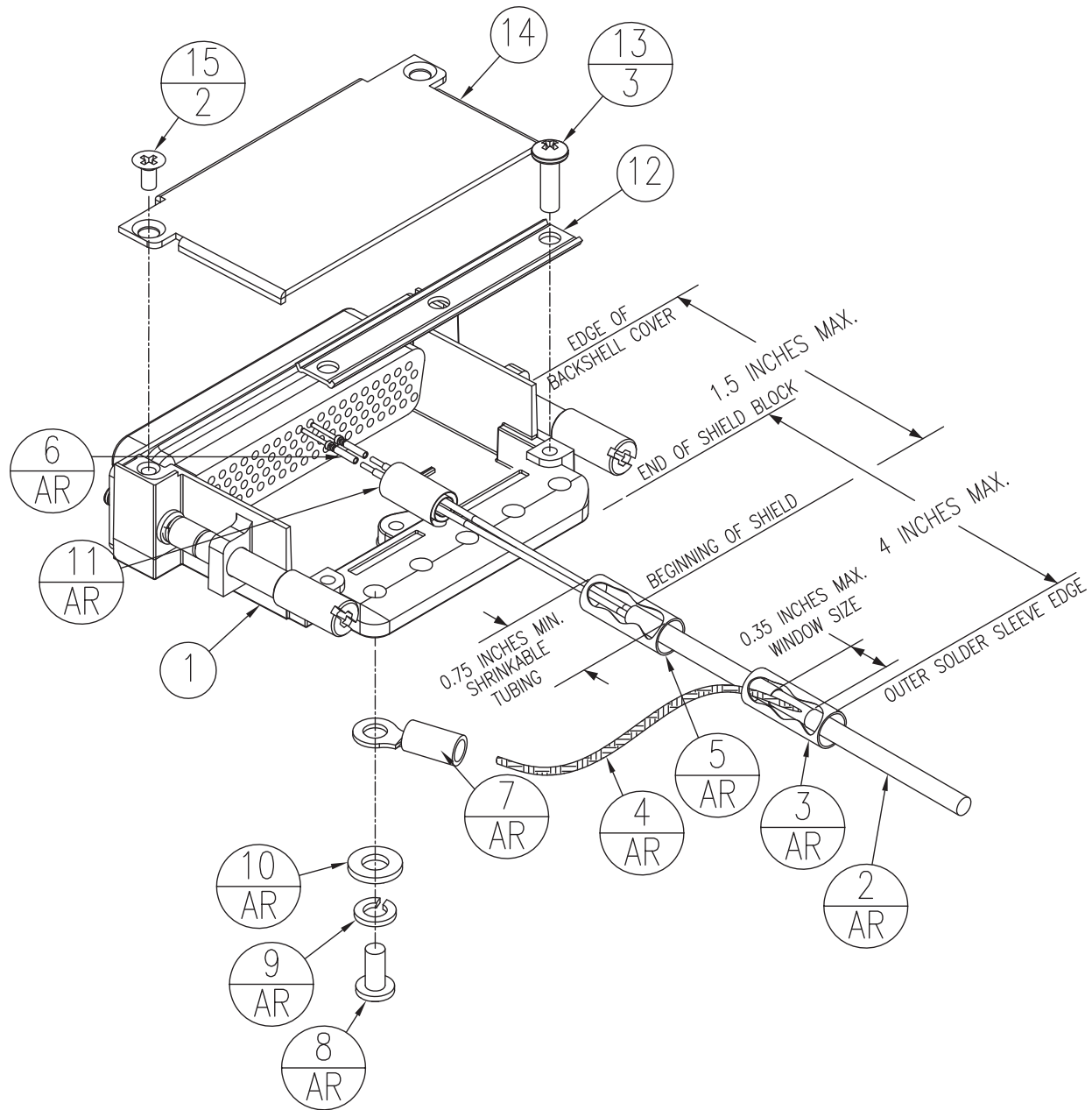

Figure 6-1 Example Shield Install onto a Jackscrew Backshell

6.2 Shield Termination Technique – Method A.1 (Standard)

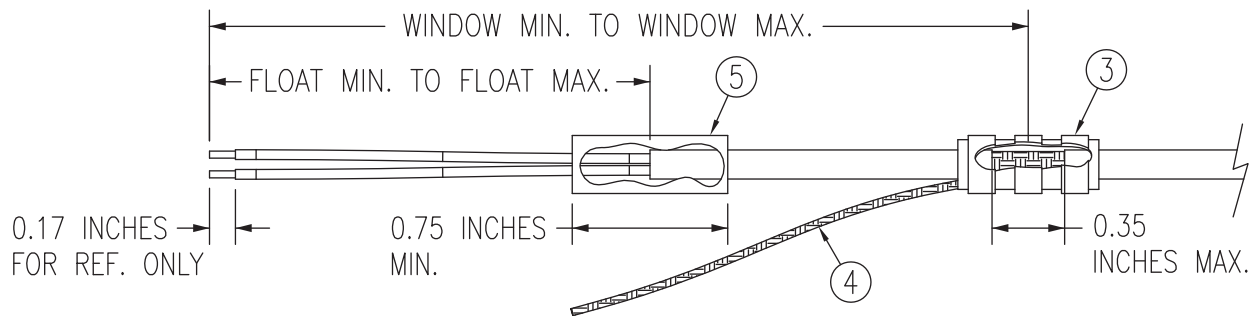

Figure 6-2 Shield Termination Technique Method A.1

Table 6-3 Shielded Cable Preparations for Garmin Connectors

Backshell Size	Number of Pins Std/HD	Float Min (inches)	Float Max (inches)	Ideal Float (inches)	Window Min (inches)	Window Max (inches)	Ideal Window (inches)
1	9/15	1.25	2.25	1.75	2.75	5.25	4.25
2	15/26	1.5	2.5	2.0	3.0	5.5	4.5
3	25/44	1.5	2.5	2.0	3.0	5.5	4.5
4	37/62	1.5	2.5	2.0	3.0	5.5	4.5
5	50/78	1.5	2.5	2.0	3.0	5.5	4.5

- At one end of a shielded cable (item 2, [Figure 6-1](#)) measure a distance between Window Min and Window Max (Table 6-3) and cut a window (with a max size of 0.35 inch) in the jacket to expose the shield. Use caution when cutting the jacket to avoid damaging the individual braids of the shield. When dealing with a densely populated connector with many cables, it may prove beneficial to stagger the windows throughout the Window Min to Window Max range. If staggering is not needed, the Ideal Window length is recommended. The following tools are recommended to make the window cut:
 - Coaxial Cable Stripper
 - Thermal Stripper
 - Sharp Razor Blade
- Connect a flat braid (item 4, [Figure 6-2](#)) to the shield exposed through the window of the prepared cable assembly from the preceding step. The flat braid should exit the front of the termination and towards the connector. The flat braid should not exit the rear of the termination and loop back towards the connector. Make the connection between the flat braid and the prepared cable assembly using an approved shield termination technique.



NOTE

FAA AC 43.13-1B Chapter 11, Section 8 (*Wiring Installation Inspection Requirements*) may be a helpful reference for termination techniques.

Preferred Method:

Slide a solder sleeve (item 3, [Figure 6-2](#)) onto the prepared cable assembly and connect the flat braid to the shield using a heat gun approved for use with solder sleeves. Using a solder sleeve with a pre-installed flat braid may ease the assembly. The chosen size of solder sleeve must accommodate both the number of conductors present in the cable and the flat braid.

Solder sleeves with pre-installed flat braid

The preferred solder sleeve is the Raychem S03 Series with a thermochromic temperature indicator (S03-02-R-9035-100, S03-03-R-9035-100, S03-04-R-9035-100). These solder sleeves come with a pre-installed braid and effectively take the place of items 3 and 4 in [Figure 6-2](#). Reference the Raychem installation procedure, RCPS 100-70, for detailed instructions. Raychem recommends the following heating tools:

- HL1802E
- AA-400 Super Heater
- CV-1981
- MiniRay
- IR-1759

Individual solder sleeves and flat braid

Solder Sleeves:

Reference the following MIL-SPECs for solder sleeves:

- M83519/1-1
- M83519/1-2
- M83519/1-3
- M83519/1-4
- M83519/1-5

Flat Braid:

Flat braids should conform to the ASTM B33 standard for tin-plated copper wire and be made up of 36 AWG strands to form an approximately 19-20 AWG equivalent flat braid. A circular mil area range of 1000 to 1300 is required. The number of individual strands in each braid bundle is not specified. Reference MIL-SPEC flat braid QQB575F36T062.



NOTE

Flat braid, as opposed to insulated wire, is specified in order to allow for a visual inspection of the conductor as required for continued airworthiness.

Secondary Method:

Solder a flat braid to the shield exposed through the window of the prepared cable assembly. Ensure a solid electrical connection through the use of acceptable soldering practices. Use care to avoid applying excessive heat that burns through the insulation of the center conductor(s) and shorts the shield to the signal wire(s). Slide a minimum of 0.75 inch of Teflon heat shrink tubing (item 3, [Figure 6-2](#)) onto the prepared wire assembly and shrink using a heat gun. The chosen size of heat shrink tubing must accommodate both the number of conductors present in the cable and the flat braid.

Teflon heat shrink tubing

Reference MIL-SPEC Teflon heat shrink tubing M23053/5-X-Y.

- At the same end of the shielded cable and ahead of the previous shield termination, strip back the jacket and shield from the end of the shielded cable to a distance between Float Min and Float Max ([Table 6-3](#)) to expose the insulated center conductor(s). If possible, the Ideal Float length is recommended.

Preferred Method:

Cut the jacket and the shield off at the same point so that no shield is exposed. Slide a minimum of 0.75 inch of Teflon heat shrink tubing (item 5, [Figure 6-2](#)) onto the cable and use a heat gun to shrink the tubing. The chosen size of heat shrink tubing must accommodate the number of conductors present in the cable.

Secondary Method:

Leave a maximum 0.35 inch of shield extending past the jacket. Fold this section of shield back over the jacket. Slide a solder sleeve (item 5, [Figure 6-2](#)) over the end of the cable and use a heat gun approved for solder sleeves to secure the connection. The chosen size of solder sleeve must accommodate the number of conductors present in the cable.

- Strip back approximately 0.17 inch of insulation from each wire of the shielded cable (item 2, [Figure 6-3](#)) and crimp a contact (item 6, [Figure 6-3](#)) to each conductor. It is the responsibility of the installer to determine the proper length of insulation to be removed. The wire must be visible in the inspection hole after crimping and the insulation must be 1/64 – 1/32 of an inch from the end of the contact as shown in [Figure 6-3](#).

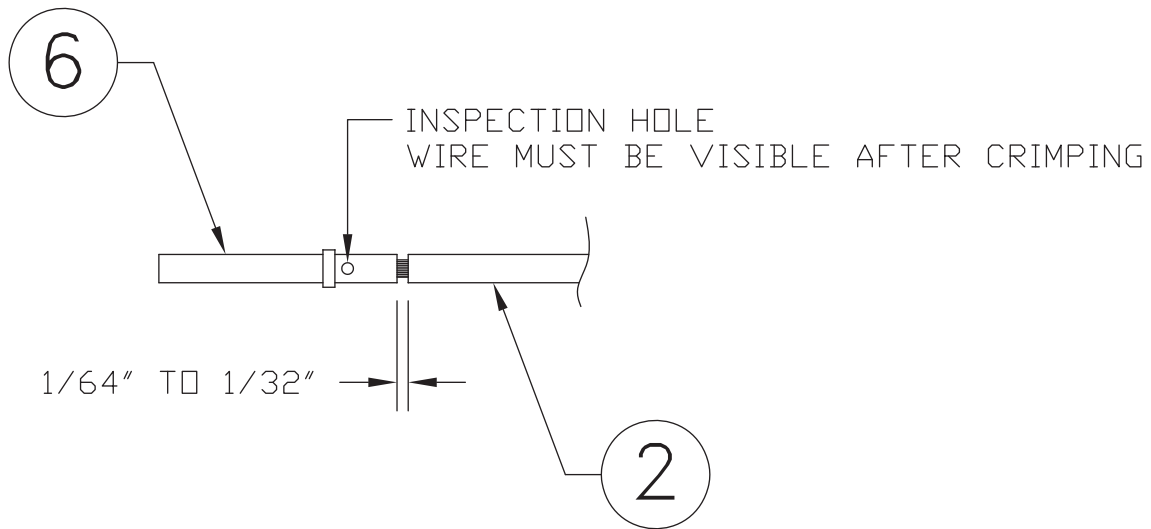

Figure 6-3 Insulation/Contact Clearance

5. Insert the newly crimped pins and wires into the appropriate connector housing location as specified by the installation wiring diagrams.
6. Cut the flat braid to a length that, with the addition of a ring terminal, will reach one of the tapped holes of the Jackscrew Backshell (item 1, [Figure 6-1](#)). An appropriate amount of excess length without looping should be given to the flat braid to allow it to freely move with the wire bundle.

**NOTE**

The window splice should be positioned such that the flat braid is no longer than 4 inches.

7. Guidelines for terminating the flat braid with an insulated ring terminal:
 - Each tapped hole on the Jackscrew Backshell may accommodate a maximum of two ring terminals.
 - Each ring terminal may accommodate a maximum of three flat braids. However, it is recommended to terminate a maximum of two flat braids per ring terminal.
 - A #8, insulated, 18-22 AWG ring terminal is recommended for terminating a single flat braid (reference MIL-SPEC MS25036-149).
 - A #8, insulated, 14-16 AWG ring terminal is recommended for terminating two flat braids (reference MIL-SPEC MS25036-153).
 - A #8, insulated, 10-12 AWG ring terminal is recommended for terminating three flat braids (reference MIL-SPEC MS25036-156).
8. Repeat the preceding steps as necessary for the remaining shielded cables.
9. Terminate the ring terminal to the Jackscrew Backshell by placing the following items on the screw (item 8, [Figure 6-1](#)) in order: split washer (item 9, [Figure 6-1](#)), flat washer (item 10, [Figure 6-1](#)), ring terminal (item 7, [Figure 6-1](#)). This assembly can then be screwed into the tapped holes on the Jackscrew Backshell.
10. It is recommended to wrap the cable bundle with silicone fusion tape (item 11, [Figure 6-1](#)) at the point where the backshell clamp (item 12, [Figure 6-1](#)) and backshell housing will contact the cable bundle.

**NOTE**

Use of silicone fusion tape is at the discretion of the installer.

11. Place the smooth side of the backshell clamp across the cable bundle and secure using the provided screws (item 13, [Figure 6-1](#)).

**WARNING**

Placing the grooved side of the backshell clamp across the cable bundle may cause damage to the wires.

12. Attach the backshell cover (item 14, [Figure 6-1](#)) to the backshell using the provided screws (item 15, [Figure 6-1](#)).

6.3 Shield Termination Technique – Method A.2 (Daisy Chain)

In rare situations where more flat braids need to be terminated for a connector than three per ring terminal it is allowable to daisy chain a maximum of two shields together before terminating to the ring terminal (Figure 6-4). All other restrictions and instructions for the shield termination set forth in Method A.1 are still applicable.



NOTE

The maximum length of the combined braids should be 4 inches.

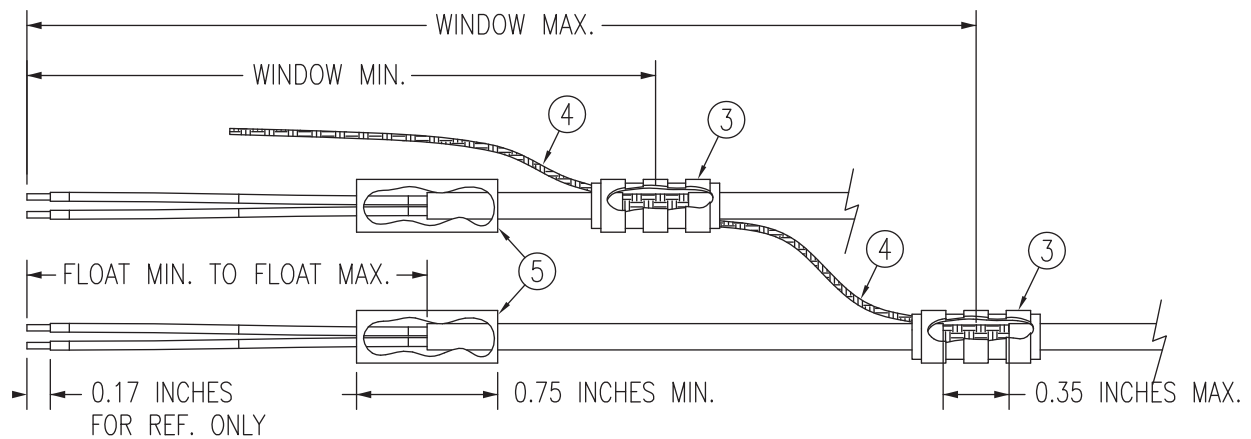

Figure 6-4 Shield Termination Technique Method A.2

6.4 Shield Termination Technique – Method B.1 (Quick Term)

If desired, the drain wire termination (item 3, [Figure 6-1](#)) and the floating shield termination (item 5, [Figure 6-1](#)) can be effectively combined into a “Quick Term”. This method eliminates the float in the cable insulation and moves the placement of the window described in Method A.1. This technique is depicted in Figure 6-5.



NOTE

The original purpose for separating the shield drain termination from the float termination in Method A.1 was to allow for a variety of lengths for the drain wires such that the shield drain terminations would not all bunch up in the harness and to eliminate loops in the drain wires. If Method B.1 is used, care must be taken to ensure that all drain shield terminations can still be inspected. Garmin recommends using Method A.1 on connectors which require a large number of shield drain terminations, as this will allow these terminations to be dispersed across a larger area.

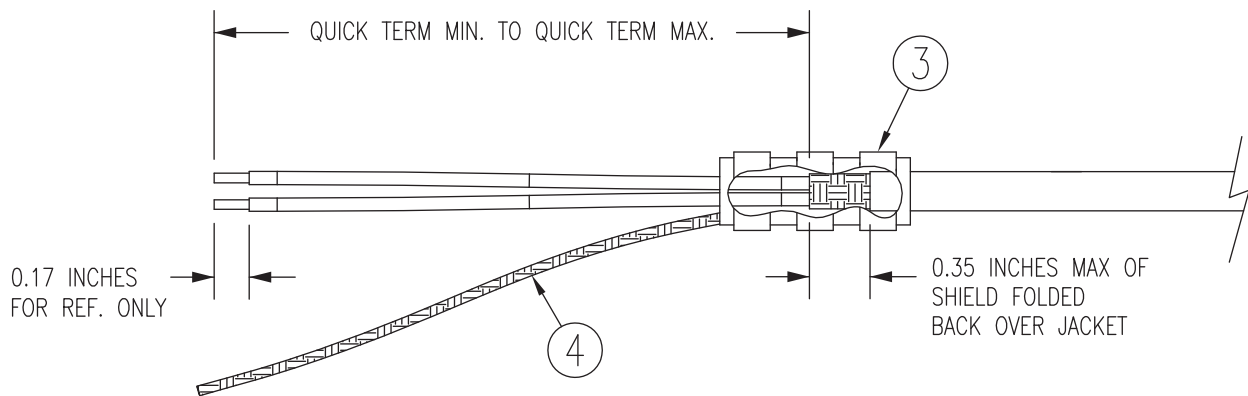

Figure 6-5 Shield Termination Technique Method B.1

1. At one end of a shielded cable (item 2, [Figure 6-1](#)) measure a distance between Window Min and Window Max ([Table 6-4](#)) and cut a window (with a max size of 0.35 inch) in the jacket to expose the shield. Use caution when cutting the jacket to avoid damaging the individual braids of the shield. When dealing with a densely populated connector with many cables, it may prove beneficial to stagger the windows throughout the Window Min to Window Max range. If staggering is not needed, the Ideal Window length is recommended. The following tools are recommended to make the window cut:
 - Coaxial Cable Stripper
 - Thermal Stripper
 - Sharp Razor Blade

Table 6-4 Shielded Cable Preparations – (Quick Term)

Backshell Size	Number of Pins Std/HD	Quick Term Min (inches)	Quick Term Max (inches)	Quick Term Float (inches)
1	9/15	1.25	2.25	1.75
2	15/26	1.5	2.5	2.0
3	25/44	1.5	2.5	2.0
4	37/62	1.5	2.5	2.0
5	50/78	1.5	2.5	2.0

- Strip back the jacket from the end of the shielded cable to a distance between Quick Term Min and Quick Term Max ([Table 6-3](#)) to expose the shield. Next trim the shield so that a maximum of 0.35 inch of shield extends beyond the jacket. Fold this section of shield back over the jacket.
- Connect a flat braid (item 4, [Figure 6-5](#)) to the folded back shield of the prepared cable assembly. The flat braid should exit the front of the termination and towards the connector. The flat braid should not exit the rear of the termination and loop back towards the connector. Make the connection between the flat braid and the prepared cable assembly using an approved shield termination technique.



NOTE

FAA AC 43.13-1B Chapter 11, Section 8 (Wiring Installation Inspection Requirements) may be a helpful reference for termination techniques.

Preferred Method:

Slide a solder sleeve (item 3, [Figure 6-5](#)) onto the prepared cable assembly and connect the flat braid to the shield using a heat gun approved for use with solder sleeves. Using a solder sleeve with a pre-installed flat braid may ease the assembly. The chosen size of solder sleeve must accommodate both the number of conductors present in the cable and the flat braid.

Secondary Method:

Solder a flat braid to the folded back shield of the prepared cable assembly. Ensure a solid electrical connection through the use of acceptable soldering practices. Use care to avoid applying excessive heat that burns through the insulation of the center conductor(s) and shorts the shield to the signal wire(s). Slide a minimum of 0.75 inch of Teflon heat shrink tubing (item 3, [Figure 6-5](#)) onto the prepared wire assembly and shrink using a heat gun. The chosen size of heat shrink tubing must accommodate both the number of conductors present in the cable and the flat braid.

Teflon heat shrink tubing

Reference MIL-SPEC Teflon heat shrink tubing M23053/5-X-Y.

- Insert the newly crimped pins and wires into the appropriate connector housing location as specified by the installation wiring diagrams.

5. Cut the flat braid to a length that, with the addition of a ring terminal, will reach one of the tapped holes of the Jackscrew Backshell (item 1, [Figure 6-1](#)). An appropriate amount of excess length without looping should be given to the flat braid to allow it to freely move with the wire bundle.

**NOTE**

The window splice should be positioned such that the flat braid is no longer than 4 inches.

6. Guidelines for terminating the flat braid with an insulated ring terminal:
 - Each tapped hole on the Jackscrew Backshell may accommodate a maximum of two ring terminals.
 - Each ring terminal may accommodate a maximum of three flat braids. However, it is recommended to terminate a maximum of two flat braids per ring terminal.
 - A #8, insulated, 18-22 AWG ring terminal is recommended for terminating a single flat braid (reference MIL-SPEC MS25036-149).
 - A #8, insulated, 14-16 AWG ring terminal is recommended for terminating two flat braids (reference MIL-SPEC MS25036-153).
 - A #8, insulated, 10-12 AWG ring terminal is recommended for terminating three flat braids (reference MIL-SPEC MS25036-156).
7. Repeat the preceding steps as necessary for the remaining shielded cables.
8. Terminate the ring terminal to the Jackscrew Backshell by placing the following items on the screw (item 8, [Figure 6-1](#)) in order: split washer (item 9, [Figure 6-1](#)), flat washer (item 10, [Figure 6-1](#)), ring terminal (item 7, [Figure 6-1](#)). This assembly can then be screwed into the tapped holes on the Jackscrew Backshell.
9. It is recommended to wrap the cable bundle with silicone fusion tape (item 11, [Figure 6-1](#)) at the point where the backshell clamp (item 12, [Figure 6-1](#)) and backshell housing will contact the cable bundle.

**NOTE**

Use of silicone fusion tape is at the discretion of the installer.

10. Place the smooth side of the backshell clamp across the cable bundle and secure using the provided screws (item 13, [Figure 6-1](#)).

**WARNING**

Warning: Placing the grooved side of the backshell clamp across the cable bundle may cause damage to the wires.

11. Attach the backshell cover (item 14, [Figure 6-1](#)) to the backshell using the provided screws (item 15, [Figure 6-1](#)).

6.5 Shield Termination Technique – Method B.2 (Daisy Chain-Quick Term)

In rare situations where more flat braids need to be terminated for a connector than three per ring terminal it is allowable to daisy chain a maximum of two shields together before terminating to the ring terminal (Figure 6-6). All other restrictions and instructions for the shield termination set forth in Method B.1 are still applicable.



NOTE

The maximum length of the combined braids should be 4 inches.

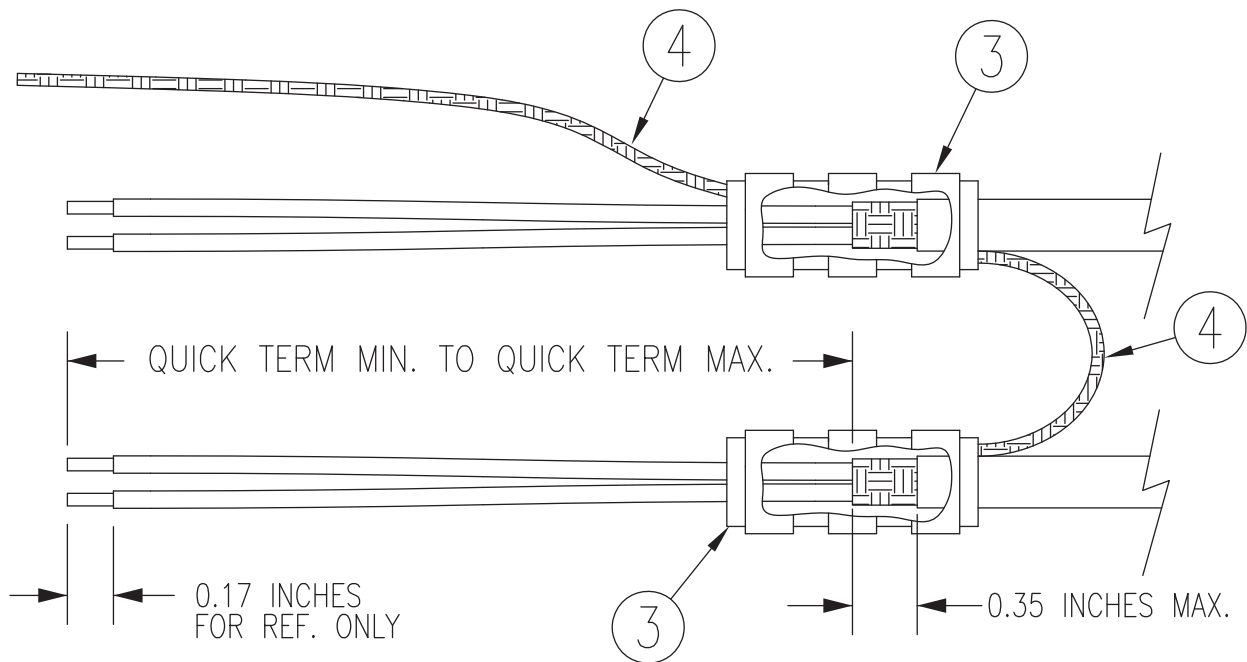

Figure 6-6 Shield Termination Technique Method B.2

6.6 Daisy Chain between Methods A.1 and B.1

In rare situations where more flat braids need to be terminated for a connector than three per ring terminal and a mixture of Methods A.1 and B.1 have been used, it is allowable to daisy chain a maximum of two shields together between a Method A.1 and B.1 termination before terminating to the ring terminal (Figure 6-7). All other restrictions and instructions for the shield termination set forth in Method A.1 and B.1 are still applicable.



NOTE

The maximum length of the combined braids should be 4 inches.

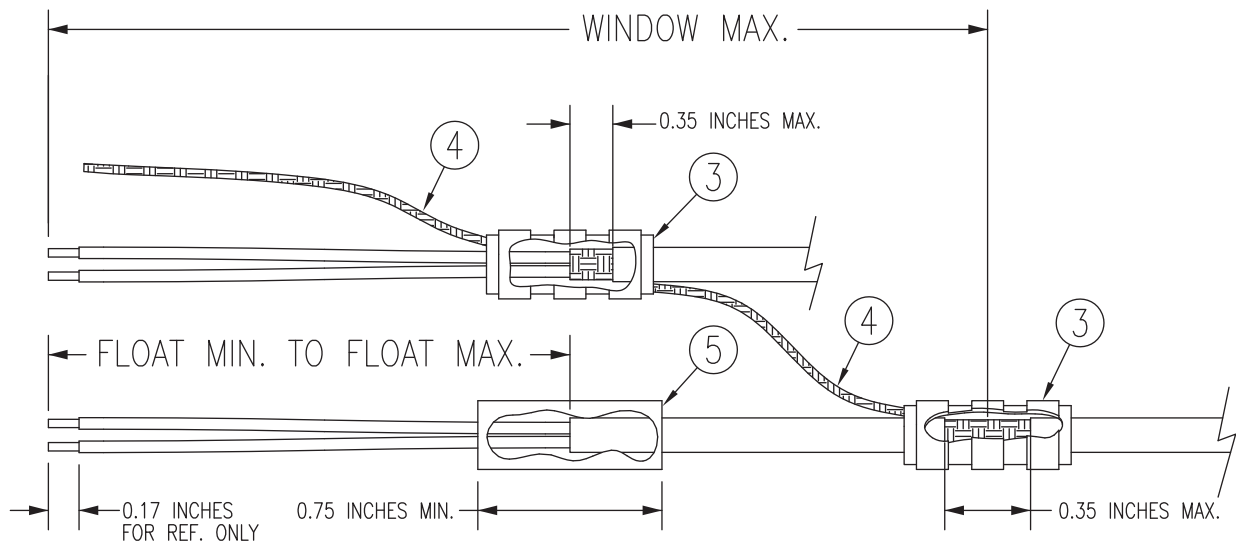

Figure 6-7 Shield Termination Technique Methods A.1 and B.1

6.7 Unit ID (Strapping)

The Unit ID Program Pin on the G5 provides a ground reference used by the hardware as a means of configuring the unit for system identification. When installing two G5 units, the second unit must have its UNIT ID pin (J51 pin 3) connected to ground. For the first G5, this pin should be left unconnected. The following instructions illustrate how this ground strapping should be accomplished with the Jackscrew Backshell.

1. Cut a 4-inch length of 22 AWG insulated wire.



WARNING

Flat braid is not permitted for this purpose. Use only insulated wire to avoid inadvertent ground issues that can occur when using exposed conductors.

2. Strip back approximately 0.17 inch of insulation and crimp a contact to the 4-inch length of wire. It is the responsibility of the installer to determine the proper length of insulation to be removed. The wire must be visible in the inspection hole after crimping and the insulation must be 1/64 – 1/32 of an inch from the end of the contact as shown in [Figure 6-3](#).
3. Insert the crimped pin and wire into the appropriate connector housing location as specified by the installation wiring diagrams.
4. At the opposite end of the wire, strip back 0.2 inch of insulation.
5. Terminate this end of the wire in conjunction with the flat braids of the shield terminations. If this ground strap is the only termination, use a #8, insulated, 18-22 AWG ring terminal for the termination (reference MIL-SPEC MS25036-149).

6.8 Splicing Signal Wires

[Figure 6-8](#) shows an example two wire splice. Note that the splice must be made within 3 inches of the Shield Block. A signal wire should be spliced into a maximum of three wires. This wire splicing technique can be used with all the shield termination methods outlined in the previous sections. The following wire splice parts are recommended:

- Raychem D-436-36/37/38
- MIL-SPEC MIL-S-81824/1



WARNING

Keep the splice out of the backshell for pin extraction, and outside of the strain relief to avoid preloading.

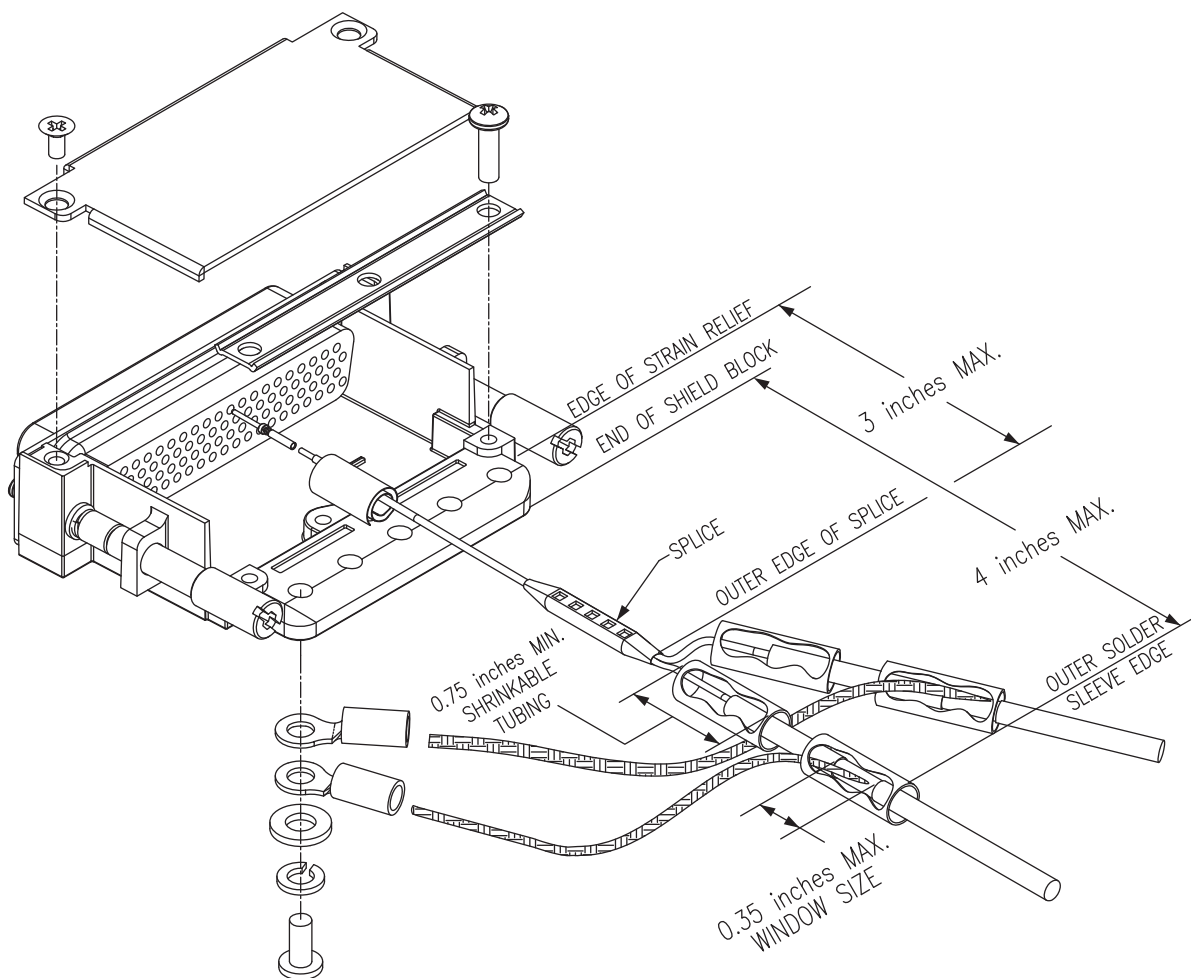
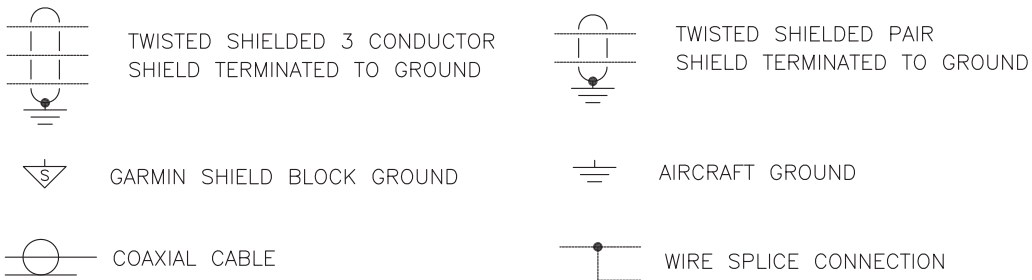

Figure 6-8 D-Sub Spliced Signal Wire Example

7 INTERCONNECT DRAWINGS

NOTES:

1. UNLESS OTHERWISE NOTED, ALL STRANDED WIRE MUST CONFORM TO MIL-W-22759/16 OR EQUIVALENT.
2. UNLESS OTHERWISE NOTED, ALL SHIELDED WIRE MUST CONFORM TO MIL-C-27500 OR EQUIVALENT.
3. UNLESS OTHERWISE NOTED, ALL WIRES ARE 22 GAUGE MINIMUM.
4. SYMBOL DESIGNATIONS



5. UNLESS OTHERWISE NOTED, ALL SHIELD GROUNDS MUST BE MADE TO THE RESPECTIVE UNIT BACKSHELLS. ALL OTHER GROUNDS SHOULD BE TERMINATED TO AIRCRAFT GROUND AS CLOSE TO THE RESPECTIVE UNIT AS POSSIBLE.
6. REFER TO THE G3X INSTALLATION MANUAL (190-01115-01) FOR INSTALLATION AND WIRING GUIDANCE FOR ALL DEVICES EXCEPT THE G5 AND THE GNC/GNS/GTN UNITS.
7. A GAD 29 A429 INTERFACE CONNECTED TO THE CAN BUS IS REQUIRED WHEN A GNS 4XX(W)/5XX(W) (INCLUDING GNS 480) OR A GTN 6XX/7XX NAVIGATOR IS USED. IN SOME DUAL NAVIGATOR INSTALLATIONS, A GAD 29 IS ALSO NEEDED TO CONNECT A GNC 255 OR SL 30 NAVIGATOR.

Figure 7-1 G5 Interconnect Notes

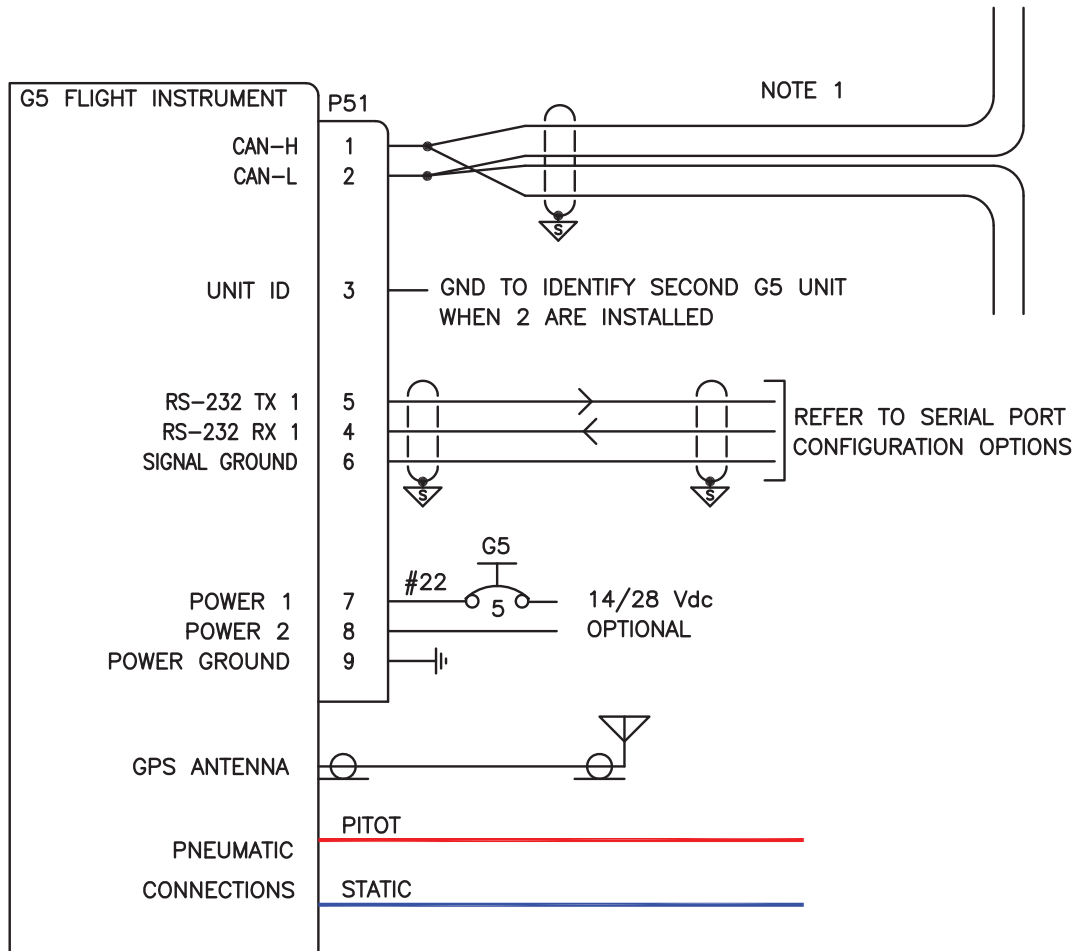

NOTES:

1. CAN BUS IS USED WHEN INSTALLED IN A G3X SYSTEM OR WHEN INSTALLED WITH GSA 28 SERVOS AND/OR GAD 29 A429 INTERFACE

CONFIGURATION GUIDANCE

1. G3X

- A. NO CONFIGURATION REQUIRED

2. G5 (WHEN NOT USED WITH THE G3X SYSTEM)

- A. ON THE G5 CONFIG MODE DEVICE INFORMATION CONFIGURATION PAGE:
 - SET THE INSTALLATION TYPE TO "STANDALONE INSTRUMENT"

Figure 7-2 G5 Standalone Interconnect Drawing

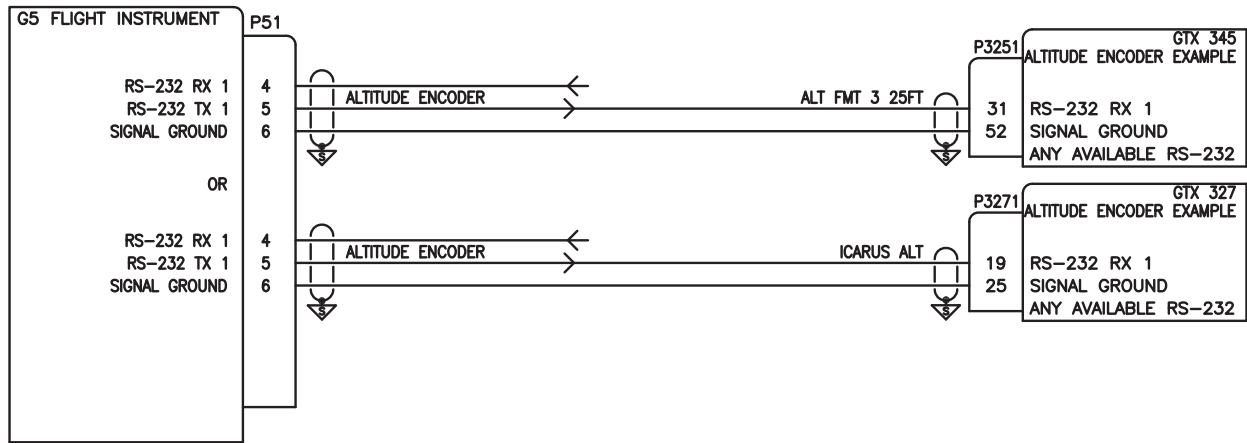

Figure 7-3 G5 Used as an Altitude Encoder Interconnect Drawing

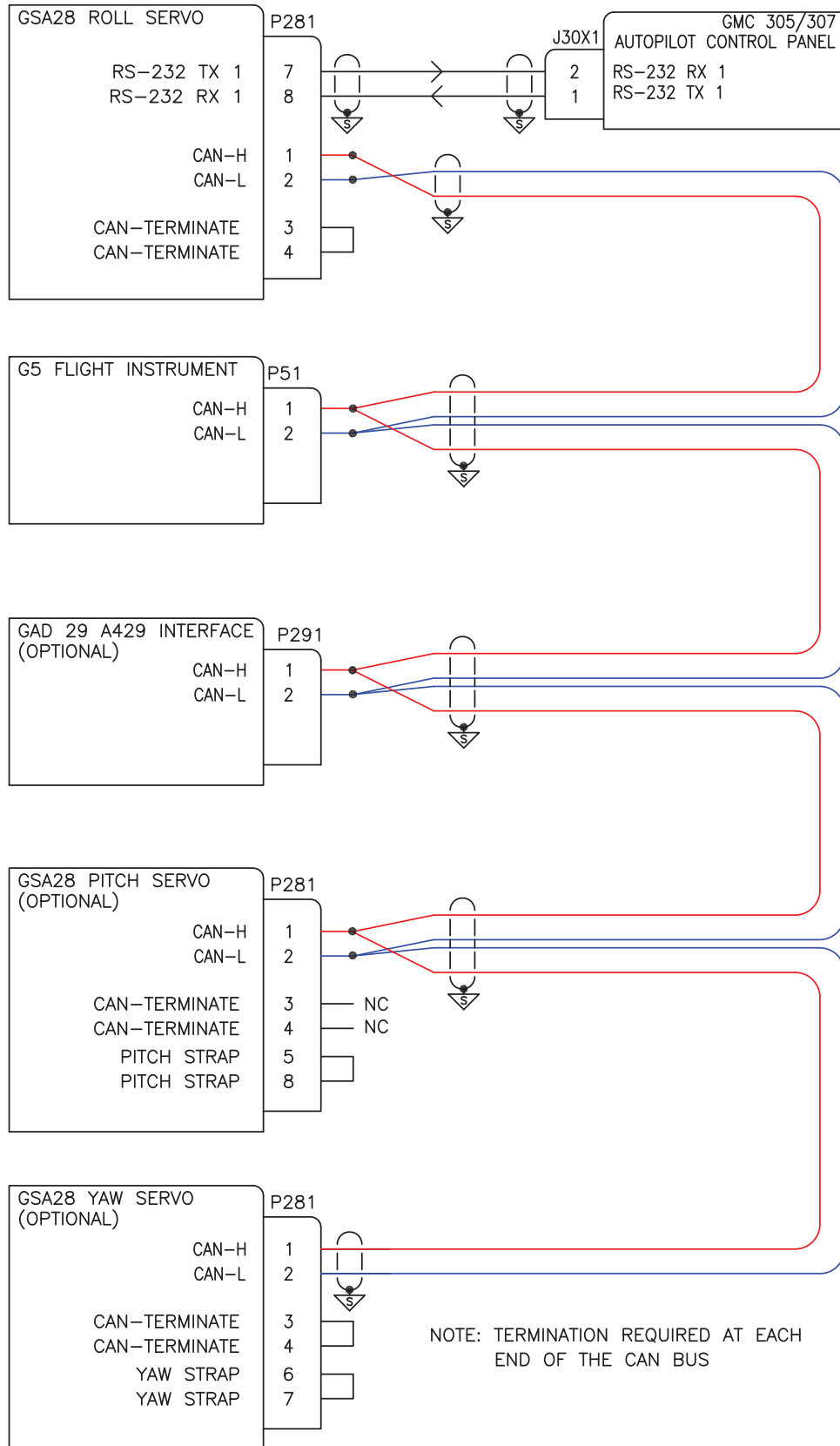
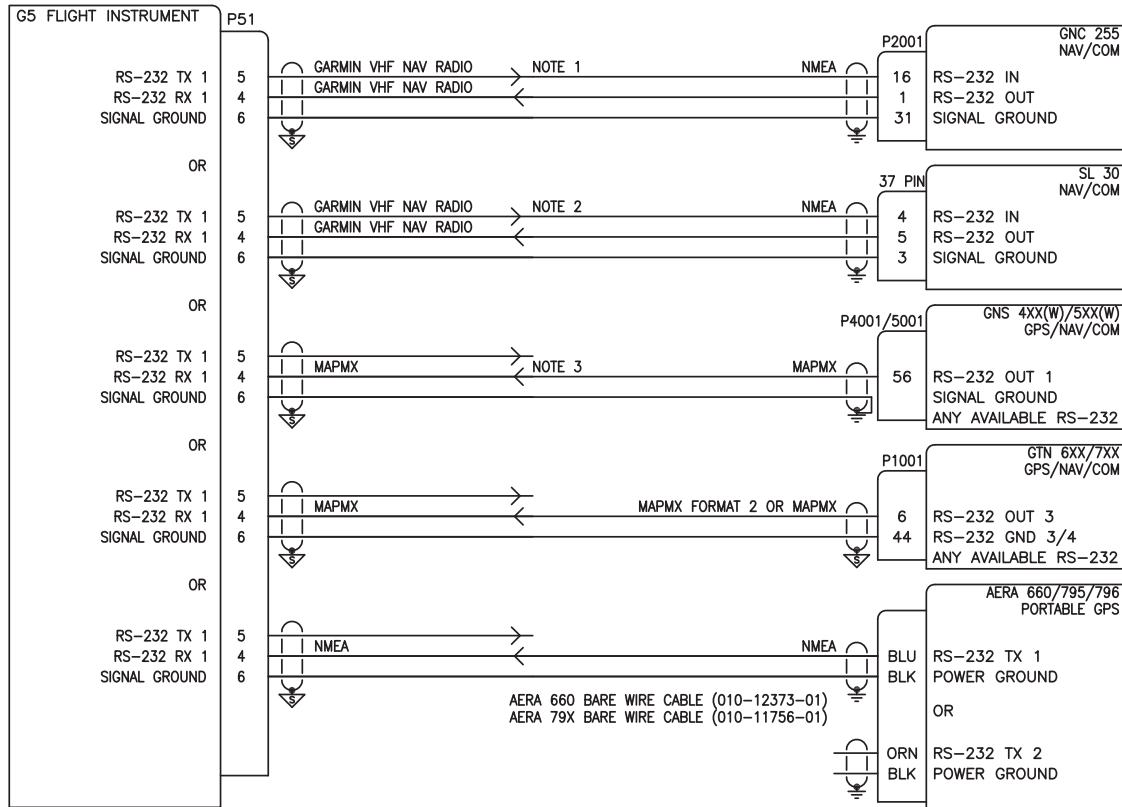

Figure 7-4 G5 CAN Bus Interconnect Drawing



NOTES

1. G5 TX CONFIGURED FOR NMEA (GNC255) WHEN MECHANICAL CDI IS IN USE
2. G5 TX NOT USED FOR SL30 WHEN MECHANICAL CDI IS IN USE
3. USE "MAPMX" FOR GNS WAAS UNITS AND "AVIATION" FOR NON-WAAS UNITS ON BOTH GNS AND G5

CONFIGURATION GUIDANCE

SL30 OR GNC255 WITHOUT MECHANICAL CDI INSTRUMENT

(RS-232 CONNECTION TO G5 IS BI-DIRECTIONAL. OBS COURSE SELECTION IS MADE ON THE G5)

- A. G5 CONFIGURATION
 - SET RS-232 INPUT AND OUTPUT FORMAT TO "GARMIN VHF NAV RADIO"
- B. NAV RADIO CONFIGURATION
 - SET GNC255 RS-232 FORMAT TO "NMEA" (NO SETTING FOR SL 30)
 - SET SL30/GNC255 INDICATOR TYPE TO "SERIAL"

SL30 OR GNC255 WITH MECHANICAL CDI INSTRUMENT

(OBS COURSE SELECTION IS MADE USING OBS KNOB ON MECHANICAL CDI)

- A. G5 CONFIGURATION
 - SET RS-232 INPUT FORMAT TO "GARMIN VHF NAV RADIO"
 - SET RS-232 OUTPUT FORMAT TO "NMEA" (OPTIONAL FOR GNC255, NO SETTING FOR SL30)
- B. NAV RADIO CONFIGURATION
 - SET GNC 255 RS-232 FORMAT TO "NMEA" (NO SETTING FOR SL30)
 - SET SL30/GNC255 INDICATOR TYPE TO "RESOLVER"

Figure 7-5 G5 to Serial Navigator Interconnect Drawing

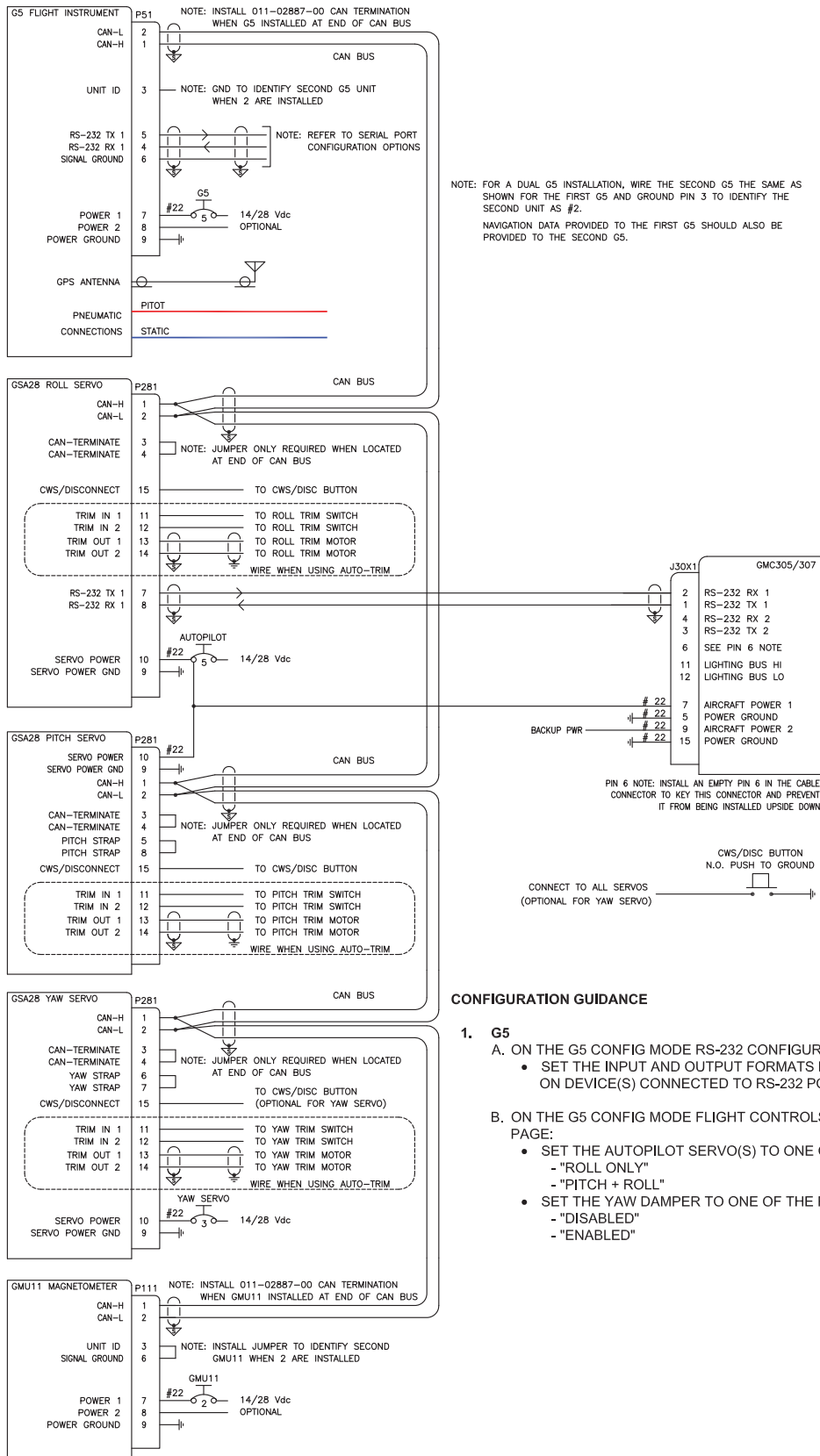

CONFIGURATION GUIDANCE

1. **G5**
 - A. ON THE G5 CONFIG MODE RS-232 CONFIGURATION PAGE:
 - SET THE INPUT AND OUTPUT FORMATS DEPENDING ON DEVICE(S) CONNECTED TO RS-232 PORT
 - B. ON THE G5 CONFIG MODE FLIGHT CONTROLS CONFIGURATION PAGE:
 - SET THE AUTOPILOT SERVO(S) TO ONE OF THE FOLLOWING:
 - "ROLL ONLY"
 - "PITCH + ROLL"
 - SET THE YAW DAMPER TO ONE OF THE FOLLOWING:
 - "DISABLED"
 - "ENABLED"

Figure 7-6 G5 with Autopilot Interconnect Drawing

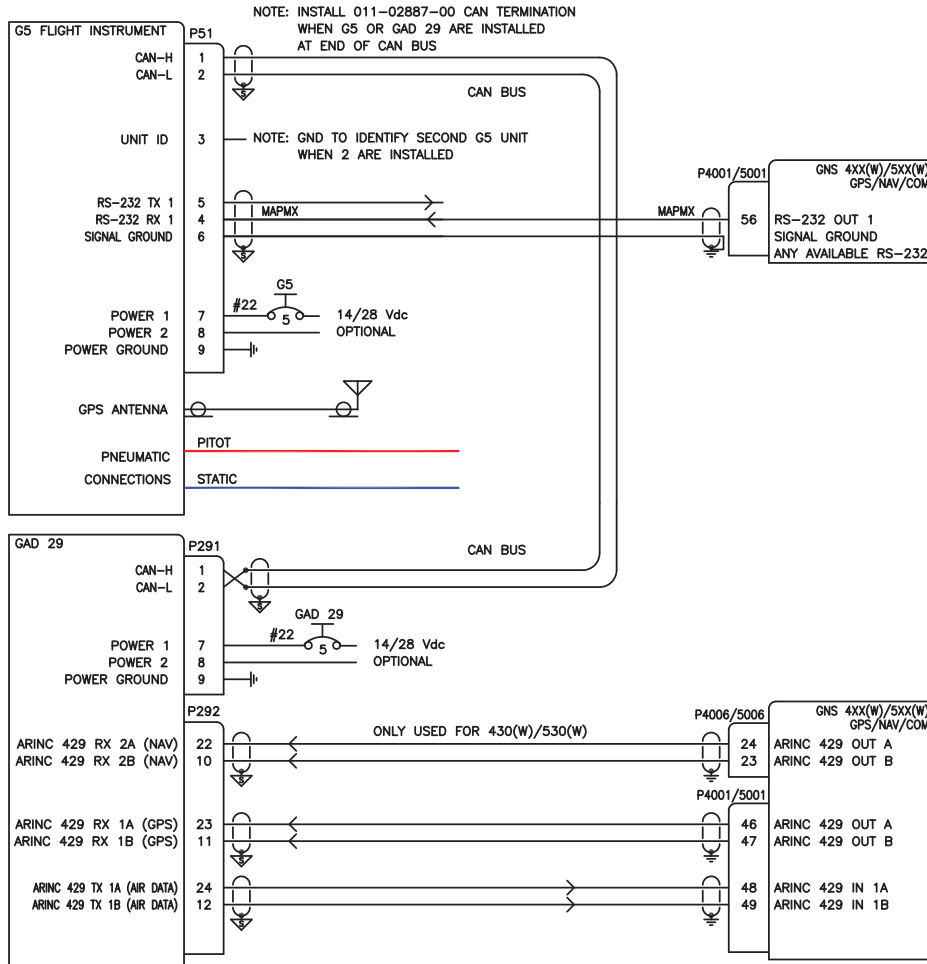

CONFIGURATION GUIDANCE

1. GNS 4XX(W)/5XX(W)

- A. ON THE CONFIG MODE MAIN ARINC 429 CONFIGURATION PAGE:
 - SET IN 1 SPEED TO "LOW"
 - SET IN 1 DATA TO "EFIS/AIRDATA"
 - SET OUT SPEED TO "LOW"
 - SET OUT DATA TO "GAMA 429"
 - SET SDI TO "LNAV 1"
 - SET VNAV TO "ENABLE LABELS" FOR GNS #1 (WAAS UNITS ONLY)
- B. ON THE CONFIG MODE MAIN CDI/OBS CONFIGURATION PAGE (GNS 430(W)/530(W) ONLY):
 - PRESS MENU AND THEN SELECT "IGNORE SEL CRS FOR VLOC?"
 - MENU WILL DISPLAY "ALLOW SEL COURSE FOR VLOC?" WHEN SET CORRECTLY
- C. ON THE CONFIG MODE VOR/LOC/GS ARINC 429 CONFIGURATION PAGE (GNS 430(W)/530(W) ONLY):
 - SET RX AND TX SPEED TO "LOW"
 - SET SDI TO "VOR/ILS 1"
- D. ON THE MAIN RS-232 CONFIG PAGE
 - SET CHNL 1 INPUT TO "OFF"
 - SET CHNL 1 OUTPUT TO "MAPMX" (WAAS UNITS) OR "AVIATION" (NON-WAAS UNITS)

2. G5

- A. ON THE G5 CONFIG MODE ARINC 429 CONFIGURATION PAGE:
 - SET OUTPUT 1 TO "EFIS/AIRDATA"
 - SET INPUT 1 TO "GARMIN GPS (SDI 1)"
 - SET INPUT 2 TO "GARMIN VOR/ILS (SDI 1)"
- B. ON THE G5 CONFIG MODE RS-232 CONFIGURATION PAGE:
 - SET INPUT FORMAT TO "MAPMX" (WAAS UNITS) OR "AVIATION" (NON-WAAS UNITS)

Figure 7-7 G5/GAD 29 to GNS 4XX/5XX Interconnect Drawing

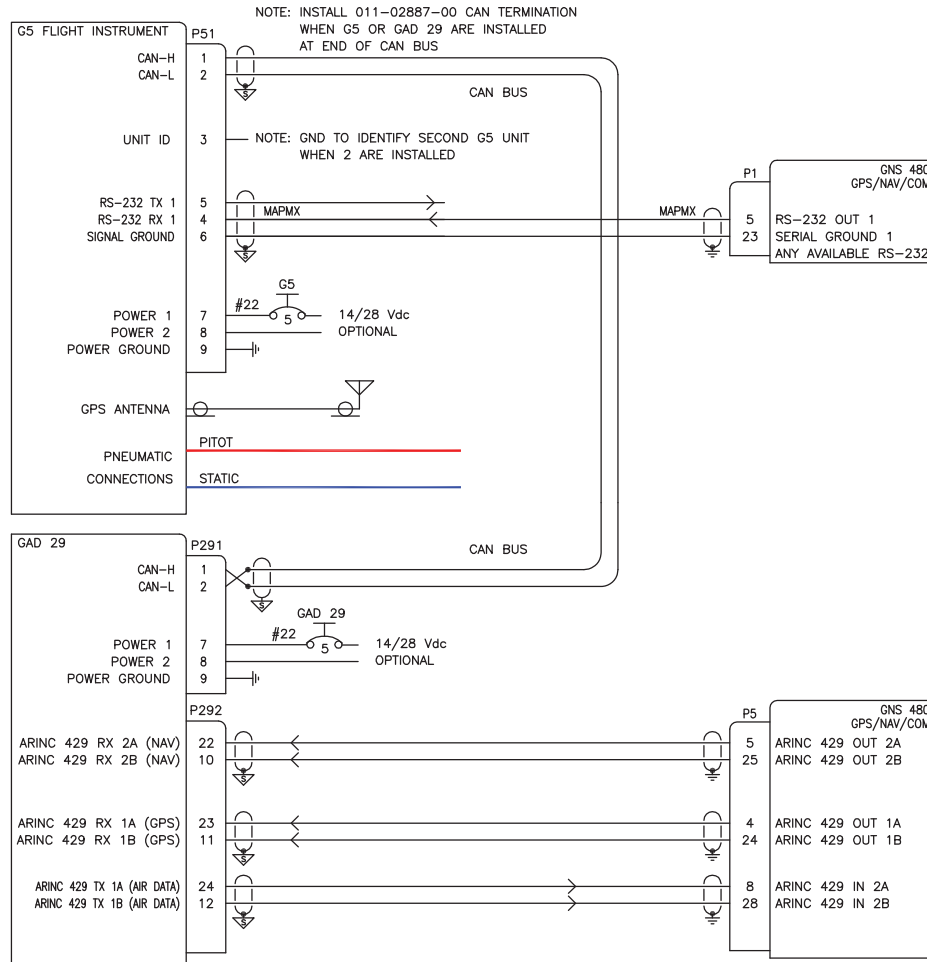

CONFIGURATION GUIDANCE

1. GNS 480

- A. ON THE GND MAINT MODE ARINC 429 SETUP PAGE:
 - SET CH_IN 2 SEL TO "EFIS"
 - SET CH_IN 2 SPEED TO "LOW"
 - SET CH_IN 2 SDI TO "SYS1"
 - SET CH_OUT 1 SEL TO "GAMA 429 NO FP"
 - SET CH_OUT 1 SPEED TO "LOW"
 - SET CH_OUT 1 SDI TO "SYS1"
 - SET CH_OUT 2 SEL TO "VOR/ILS"
 - SET CH_OUT 2 SPEED TO "LOW"
 - SET CH_OUT 2 SDI TO "SYS1"
- B. ON THE GND MAINT MODE RESOLVER INTERFACE SETUP PAGE:
 - SET RESOLVER TO "NOT INSTALLED"
- C. ON THE GND MAINT MODE MISCELLANEOUS SETUP PAGE:
 - SET CDI SELECT TO "USE"
- D. ON THE GND MAINT MODE SERIAL SETUP PAGE:
 - SET CHNL 1 OUTPUT TO "MAPMX"

2. G5

- A. ON THE G5 CONFIG MODE ARINC 429 CONFIGURATION PAGE:
 - SET OUTPUT 1 TO "EFIS/AIRDATA"
 - SET INPUT 1 TO "GARMIN GPS (SDI 1)"
 - SET INPUT 2 TO "GARMIN VOR/ILS (SDI 1)"
- B. ON THE G5 CONFIG MODE RS-232 CONFIGURATION PAGE:
 - SET INPUT FORMAT TO "MAPMX"

Figure 7-8 G5/GAD 29 to GNS 480 Interconnect Drawing

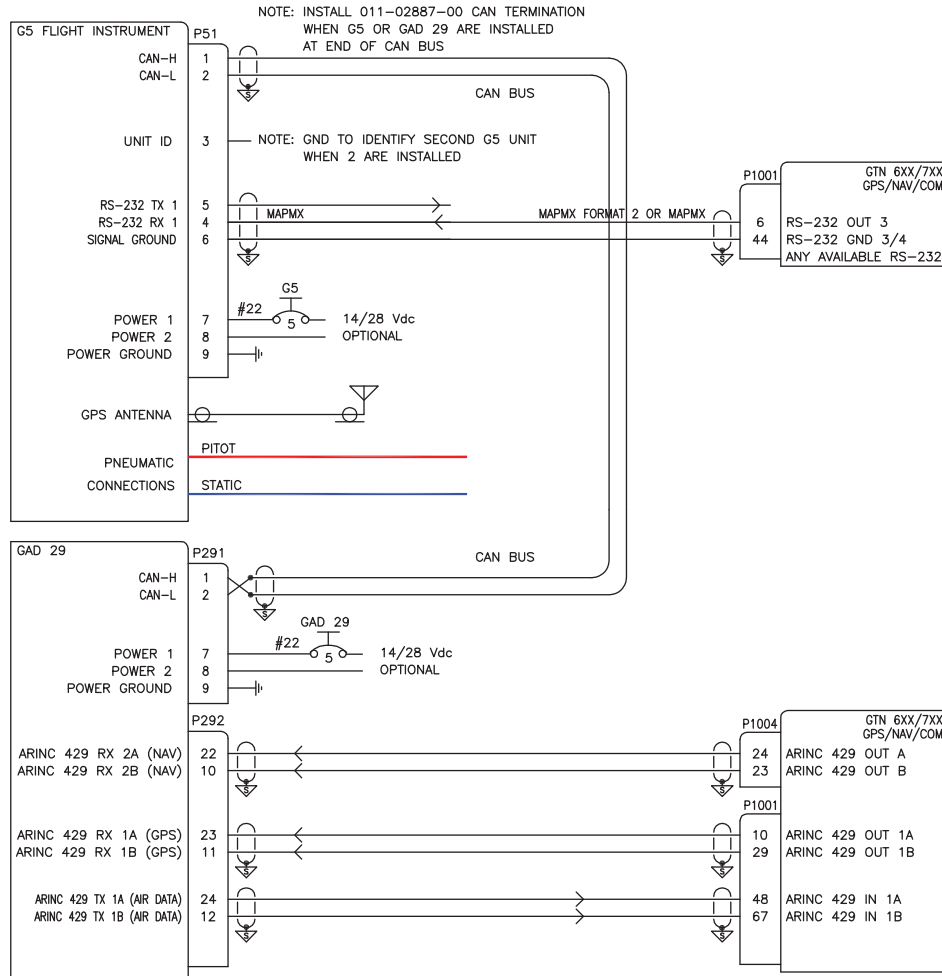

CONFIGURATION GUIDANCE

1. GTN 6XX/7XX

A. ON THE CONFIG MODE ARINC 429 CONFIGURATION PAGE:

- SET IN 1 SPEED TO "LOW"
- SET IN 1 DATA TO "EFIS FORMAT 2"
- SET OUT 1 SPEED TO "LOW"
- SET OUT 1 DATA TO "GAMA FORMAT 1"
- SET OUT 1 SDI TO "LNAV 1"

B. ON THE CONFIG MODE MAIN INDICATOR (ANALOG) CONFIGURATION PAGE:

- SET SELECTED COURSE FOR VLOC TO "IGNORED"

C. ON THE CONFIG MODE VOR/LOC/GS CONFIGURATION PAGE:

- SET NAV RADIO TO "ENABLED"
- SET TX SPEED TO "LOW"
- SET SDI TO "VOR/ILS 1"

D. ON THE RS-232 CONFIG PAGE

- SET CHNL 3 INPUT TO "MAPMX FORMAT 2" WHEN THIS FORMAT IS AVAILABLE
- SET CHNL 3 OUTPUT TO "MAPMX" WHEN "MAPMX FORMAT 2" INPUT NOT AVAILABLE

2. G5

A. ON THE G5 CONFIG MODE ARINC 429 CONFIGURATION PAGE:

- SET OUTPUT 1 TO "EFIS/AIRDATA"
- SET INPUT 1 TO "GARMIN GPS (SDI 1)"
- SET INPUT 2 TO "GARMIN VOR/ILS (SDI 1)"

B. ON THE G5 CONFIG MODE RS-232 CONFIGURATION PAGE:

- SET INPUT FORMAT TO "MAPMX"

Figure 7-9 G5/GAD 29 to GTN 6XX/7XX Interconnect Drawing

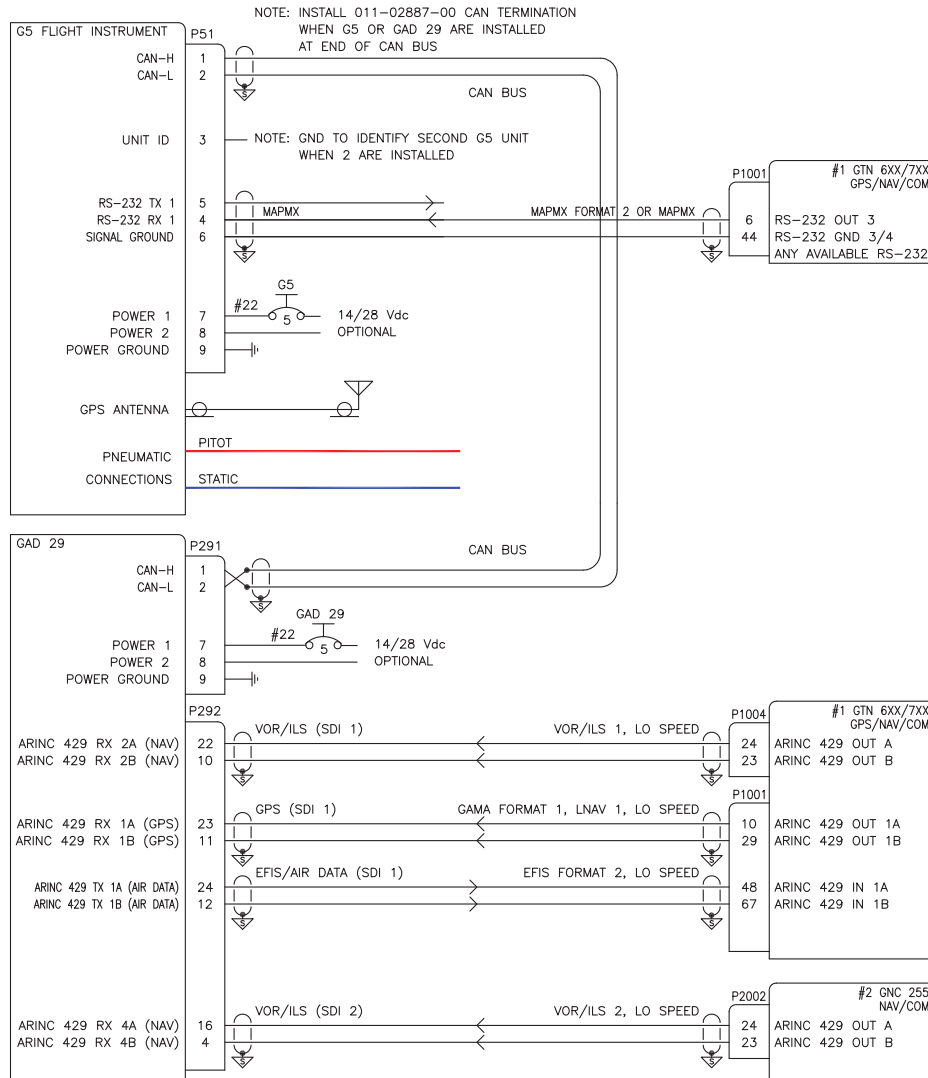

CONFIGURATION GUIDANCE

1. GTN 6XX/7XX

- A. ON THE CONFIG MODE ARINC 429 CONFIGURATION PAGE:
 - CONFIGURE ALL ARINC 429 PORTS AS SHOWN ABOVE
- B. ON THE CONFIG MODE MAIN INDICATOR (ANALOG) CONFIGURATION PAGE:
 - SET SELECTED COURSE FOR VLOC TO "IGNORED"
- C. ON THE CONFIG MODE VOR/LOC/GS CONFIGURATION PAGE:
 - SET NAV RADIO TO "ENABLED"
 - SET TX SPEED TO "LOW"
 - SET SDI TO "VOR/ILS 1"
- D. ON THE RS-232 CONFIG PAGE
 - SET CHNL 3 INPUT TO "MAPMX FORMAT 2" WHEN THIS FORMAT IS AVAILABLE
 - SET CHNL 3 OUTPUT TO "MAPMX" WHEN "MAPMX FORMAT 2" INPUT NOT AVAILABLE

2. G5

- A. ON THE G5 CONFIG MODE ARINC 429 CONFIGURATION PAGE:
 - CONFIGURE IN/OUT PORTS AS SHOWN ABOVE
- B. ON THE G5 CONFIG MODE RS-232 CONFIGURATION PAGE:
 - SET INPUT FORMAT TO "MAPMX"

3. GNC 255

- A. SET ARINC 429 PORT CONFIGURATION TO "VOR/ILS 2" AND "LO SPEED"
- B. SET CDI INDICATOR TYPE TO "NONE" ON NAV CONFIGURATION PAGE

Figure 7-10 G5/GAD 29 to GTN/GNC 255 Dual Nav Interconnect Drawing

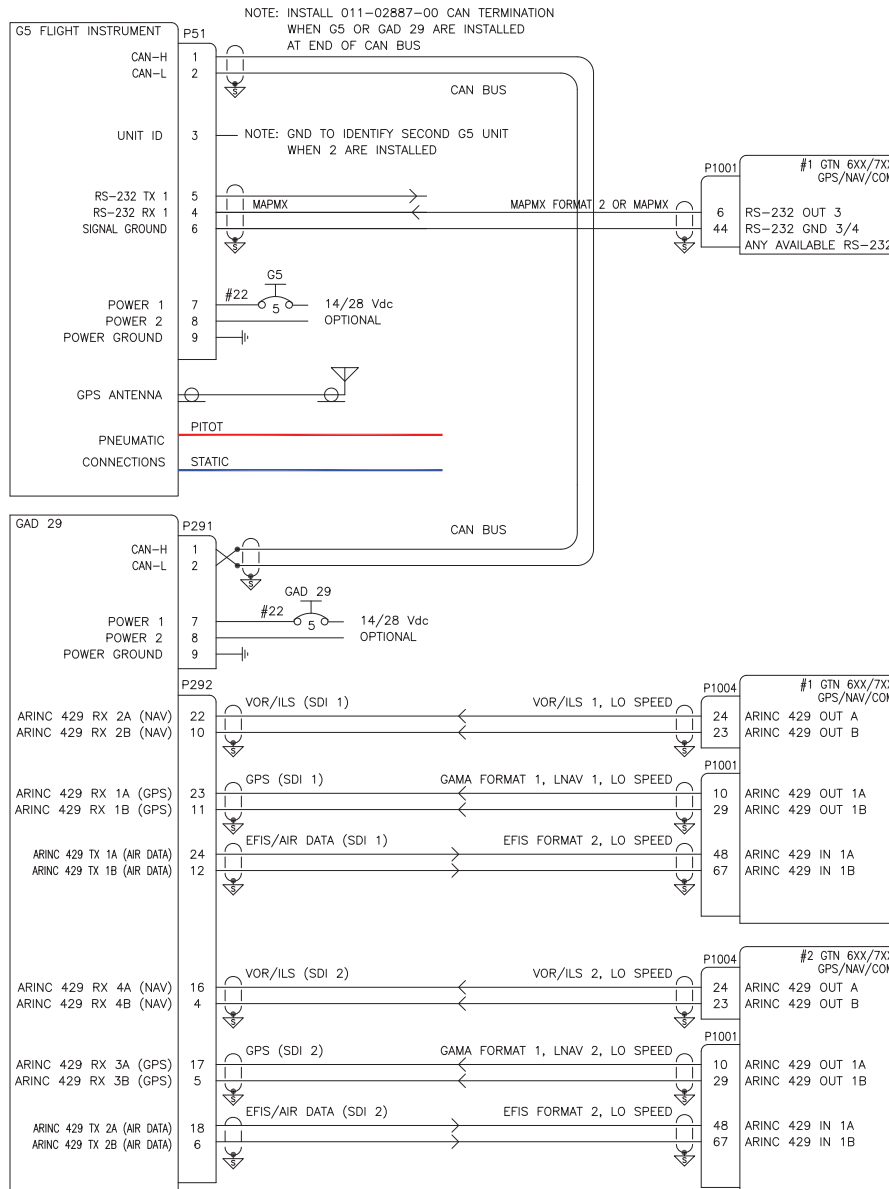

CONFIGURATION GUIDANCE

1. GTN 6XX/7XX

- A. ON THE CONFIG MODE ARINC 429 CONFIGURATION PAGE:
 - CONFIGURE ALL ARINC 429 PORTS AS SHOWN ABOVE
- B. ON THE CONFIG MODE MAIN INDICATOR (ANALOG) CONFIGURATION PAGE:
 - SET SELECTED COURSE FOR VLOC TO "IGNORED"
- C. ON THE CONFIG MODE VOR/LOC/GS CONFIGURATION PAGE:
 - SET NAV RADIO TO "ENABLED"
 - SET TX SPEED TO "LOW"
 - SET SDI TO "VOR/ILS 1" FOR #1 GTN, "VOR/ILS 2" FOR #2 GTN
- D. ON THE RS-232 CONFIG PAGE
 - SET CHNL 3 INPUT TO "MAPMX FORMAT 2" WHEN THIS FORMAT IS AVAILABLE
 - SET CHNL 3 OUTPUT TO "MAPMX" WHEN "MAPMX FORMAT 2" INPUT NOT AVAILABLE

2. G5

- A. ON THE G5 CONFIG MODE ARINC 429 CONFIGURATION PAGE:
 - CONFIGURE IN/OUT PORTS AS SHOWN ABOVE
- B. ON THE G5 CONFIG MODE RS-232 CONFIGURATION PAGE:
 - SET INPUT FORMAT TO "MAPMX"

Figure 7-11 G5/GAD 29 to GTN/GTN Dual Nav Interconnect Drawing

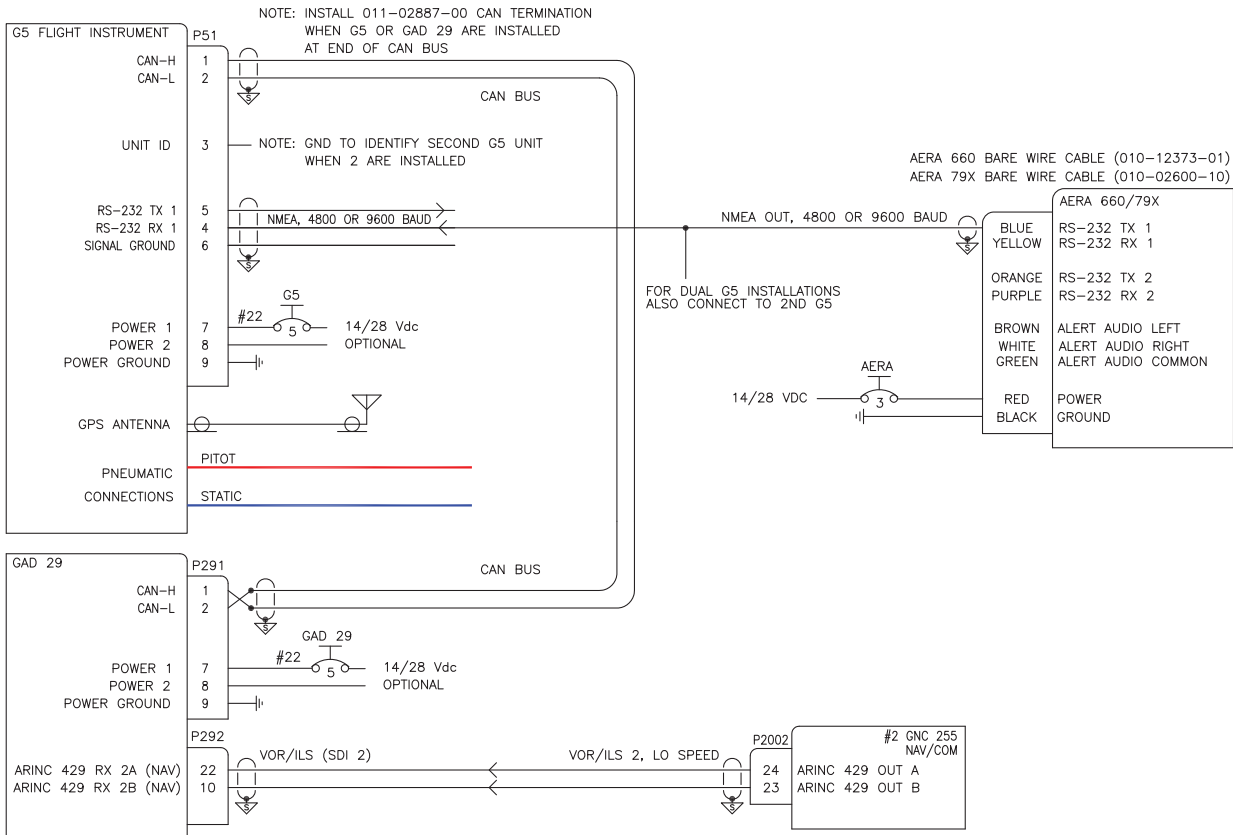

CONFIGURATION GUIDANCE

1. AERA 660/795/796

- A. ON THE RS-232 INTERFACE SETUP PAGE:
 - CONFIGURE SERIAL PORT 1 TO "NMEA OUT" AND MAKE SURE BAUD RATE ON G5 AND PORTABLE AGREE

2. G5

- A. ON THE G5 CONFIG MODE ARINC 429 CONFIGURATION PAGE:
- B. CONFIGURE ALL ARINC 429 PORTS AS SHOWN ABOVE
- C. ON THE G5 CONFIG MODE RS-232 CONFIGURATION PAGE:
 - SET INPUT FORMAT TO "NMEA" AND SET BAUD RATE TO 4800 OR 9600 TO MATCH PORTABLE CONFIGURATION

3. GNC 255

- A. SET ARINC 429 PORT CONFIGURATION TO "VOR/ILS 2" AND "LO SPEED"
- B. SET CDI INDICATOR TYPE TO "NONE" ON NAV CONFIGURATION PAGE

Figure 7-12 G5/GAD 29 to aera/GNC 255 Dual Nav Interconnect Drawing

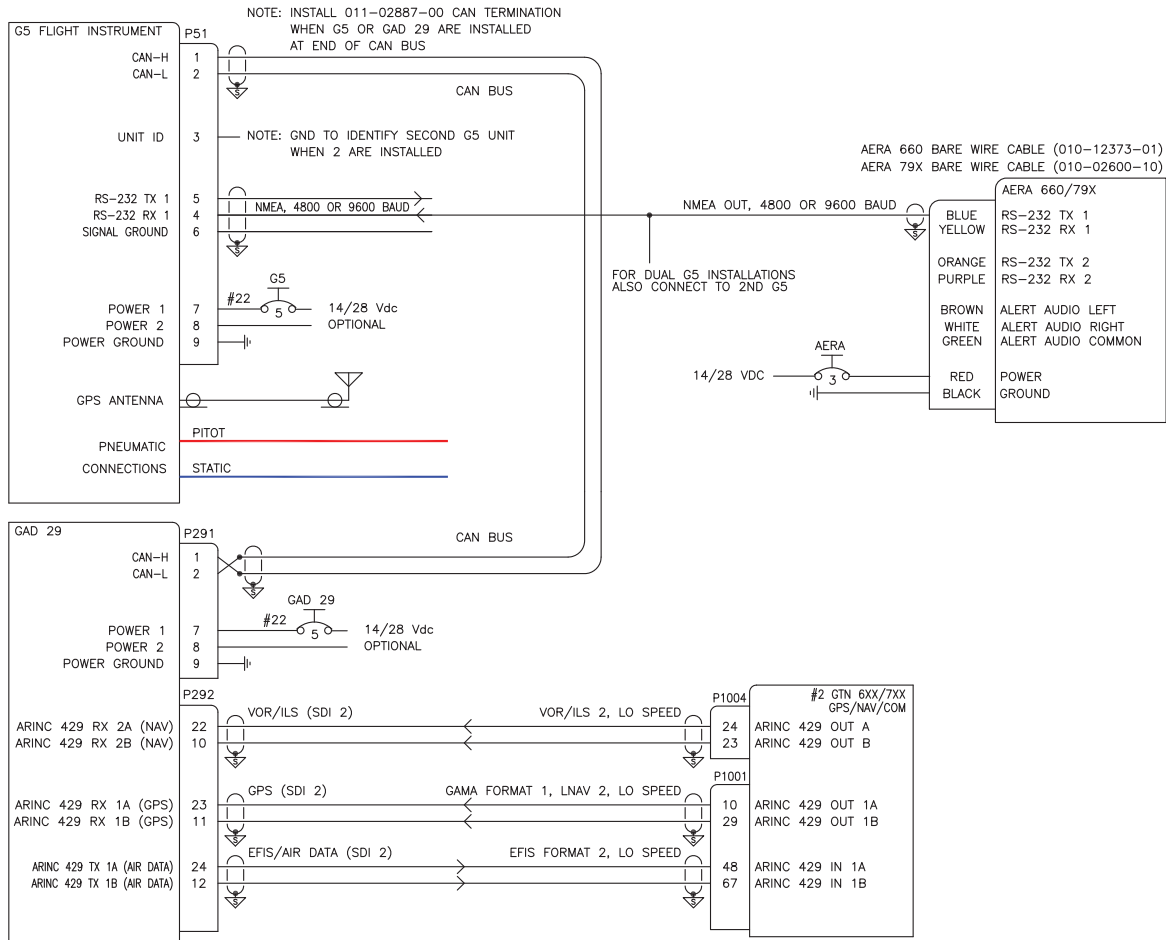

CONFIGURATION GUIDANCE

1. GTN 6XX/7XX

A. ON THE CONFIG MODE ARINC 429 CONFIGURATION PAGE:

- SET IN 1 SPEED TO "LOW"
- SET IN 1 DATA TO "EFIS FORMAT 2"
- SET OUT 1 SPEED TO "LOW"
- SET OUT 1 DATA TO "GAMA FORMAT 1"
- SET OUT 1 SDI TO "LNAV 2"

B. ON THE CONFIG MODE MAIN INDICATOR (ANALOG) CONFIGURATION PAGE:

- SET SELECTED COURSE FOR VLOC TO "IGNORED"

C. ON THE CONFIG MODE VOR/LOC/GS CONFIGURATION PAGE:

- SET NAV RADIO TO "ENABLED"
- SET TX SPEED TO "LOW"
- SET SDI TO "VOR/ILS 2"

2. AERA 660/795/796

A. ON THE RS-232 INTERFACE SETUP PAGE:

- CONFIGURE SERIAL PORT 1 TO "NMEA OUT" AND MAKE SURE BAUD RATE ON G5 AND PORTABLE AGREE

3. G5

D. ON THE G5 CONFIG MODE ARINC 429 CONFIGURATION PAGE:

- SET OUTPUT 1 TO "EFIS/AIRDATA"
- SET INPUT 1 TO "GARMIN GPS (SDI 2)"
- SET INPUT 2 TO "GARMIN VOR/ILS (SDI 2)"

B. ON THE G5 CONFIG MODE RS-232 CONFIGURATION PAGE:

- SET INPUT FORMAT TO "NMEA" AND MAKE SURE BAUD RATE ON G5 AND PORTABLE MATCH

Figure 7-13 G5/GAD 29 to aera/GTN 6XX/7XX Dual Nav Interconnect Drawing

8 G5 CONFIGURATION AND POST INSTALLATION CHECKOUT

The checkout procedures in this section are recommended to be performed after installing the G5. The calibration procedures are required to be performed after installing the G5. It is assumed that the person performing these checks is familiar with the aircraft, has a working knowledge of typical avionics systems, and has experience using the test equipment defined in this section.



NOTE

See G5 Pilot's Guide for operational instructions.



NOTE

Some procedures in this section require that the GPS receiver is receiving sufficient satellite signal to compute a present position. This requires outdoor line of sight to GPS satellite signals or a GPS indoor repeater.



NOTE

As these procedures involve engine run-up and moving the aircraft, it is recommended that the installer read this entire section before beginning the checkout procedure.



NOTE

All test equipment should have current calibration records.



CAUTION

Be sure to check all aircraft control movements before flight is attempted to ensure that the wiring harness does not touch any moving part.

8.1 Recommended Test Equipment

The following test equipment is recommended to conduct and complete all post installation checkout procedures in this section:

- Digital Multi-Meter (DMM) for power troubleshooting and wiring connection check
- Ground power unit capable of supplying 14/28 Vdc power to the aircraft systems and avionics
- Outdoor line of sight to GPS satellite signals or GPS indoor repeater
- Digital level or equivalent
- Pitot/static ramp tester (only required if unit fails a periodic static system test)

8.2 Configuration Mode

All of the configuration and calibration procedures in this section are performed in configuration mode. To enter configuration mode, hold down the knob while powering on the G5.

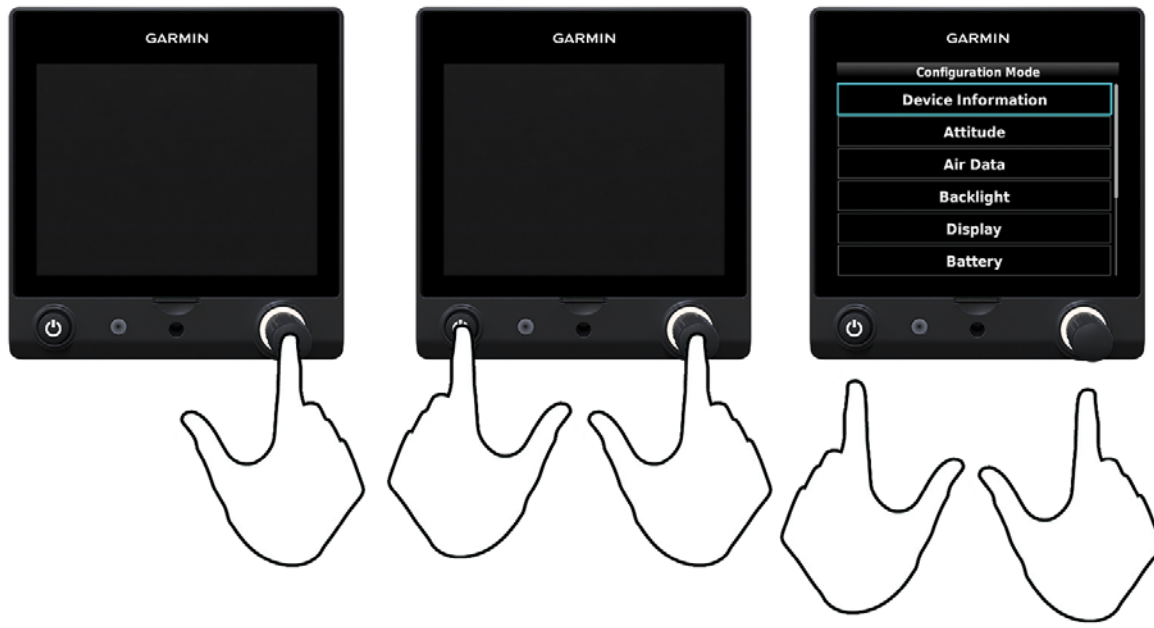

Figure 8-1 Entering Configuration Mode

8.3 Software Loading Procedure

G5 software loading can be performed in either normal or configuration system mode. Manually loading software to the G5 is not required when the G5 is installed as part of a G3X system.

1. Power on the G5, then insert a properly formatted microSD™ card into the microSD™ card slot.



NOTE

It is also acceptable to insert the microSD™ card before powering on the unit.

2. A software update message appears on the screen. Select OK to begin the update.



NOTE

The software update message will only be displayed if the version of software to be loaded is newer than the version currently on the unit.

3. The unit will reboot to the software update screen and the software update will begin automatically. This screen will show the progress of the software update.
4. Ensure power is not removed while the update is being performed.
5. The unit will reboot after the update is complete.
6. The new software version may be viewed while the unit powers on or in the configuration mode menu.

8.4 Configuration Pages

8.4.1 Device Information Page



NOTE

When a G5 is installed as part of a G3X system, some configuration pages are not available because configuration settings are automatically transferred from the GDU 37X/4XX to the G5.

The Device Information page displays LRU (device) specific information such as the software versions of devices connected to the G5. The devices listed on this page are dependent upon the Installation Type setting (G3X System Backup or Standalone Instrument). Faults are indicated by a red "X" next to the affected LRU.

Device Information		
<input checked="" type="checkbox"/>	ROLL	GSA 28 3.20
<input checked="" type="checkbox"/>	PITCH	GSA 28 3.20
<input checked="" type="checkbox"/>	YD	GSA 28 3.20
<input checked="" type="checkbox"/>	GMC	GMC 305 2.00

Figure 8-2 Device Information Page

The G5 can be configured as a Standalone Unit or (if connected to a G3X system) it will automatically be configured as G3X Backup Unit. When connected to a G3X system, the G5 will not allow the Installation Type setting to be changed (as long as the G5 is communicating with G3X LRUs). To select the Installation Type:

1. Power on the unit in configuration mode.
2. Select Device Information.
3. Scroll to select Installation Type, and press the knob.
4. Select either G3X System Backup or Standalone Instrument.

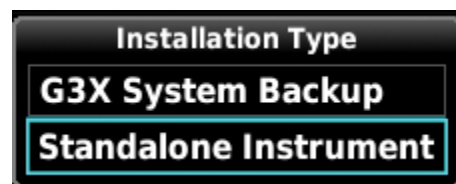

Figure 8-3 Installation Type Page

8.4.2 Attitude Configuration Page

The Attitude Configuration page is used to configure user display preferences and to complete the post-installation calibration procedures.

Table 8-1 Attitude Configuration Settings

Configuration Setting	Description
Indicator Type	<p>Select Normal to display a triangular aircraft reference symbol indicator on the PFD (similar to single cue). Select Alternate to display a cross-pointer aircraft reference symbol (similar to dual-cue).</p> <p>This setting is only present when the Installation Type setting is configured as a Standalone Unit and the installation does not have an autopilot configured.</p>
Pitch Display	<p>Adjusts the scale of the pitch ladder on the PFD. Compact spaces the pitch markings closer together. Normal mimics the spacing of typical mechanical attitude indicators. Expanded spaces the markings further apart.</p>

Table 8-1 Attitude Configuration Settings



<p>Roll Display</p>	<p>The roll (bank angle) indication may be selected to be a Ground Pointer (default) or a Sky Pointer configuration.</p>  <p>For the more common Ground Pointer configuration, both the roll arc and the pitch ladder remain anchored to the horizon and the roll pointer beneath the roll arc points to the present roll angle.</p>  <p>For the Sky Pointer configuration, the pitch ladder continues to roll with the horizon, but the roll arc remains fixed and centered in the display. The roll pointer beneath the roll arc moves with the horizon and in the opposite direction to aircraft roll.</p>
<p>Vibration Test</p>	<p>Validates the vibration characteristics of the G5 installation. See Section 8.4.6.2 for more information.</p>

Table 8-1 Attitude Configuration Settings

<p>Calibrate Yaw Offset</p>	<p>Allows for direct manual entry of the present yaw offset when the instrument panel to which the G5 is mounted is not perpendicular to the aircraft centerline. The limit on this setting is +/- 15 degs. Positive is clockwise.</p> 
<p>Calibrate Pitch/Roll</p>	<p>Calibrates the G5's pitch and roll measurements to a known level attitude. See Section 8.4.6.1 for more information.</p>
<p>Pitch Calibration</p>	<p>Allows for direct manual entry or adjustment of the present pitch offset. The limit on this setting is +/- 30 degs. Positive is pitch up. For example, an aircraft that is continuously indicating a pitch attitude that is 2 degs high would need to reduce this pitch offset value by 2 degs.</p>
<p>Roll Calibration</p>	<p>Allows for direct manual entry or adjustment of the present roll offset. The limit on this setting is +/- 2 degs. Positive is roll right.</p>
<p>User Pitch Offset</p>	<p>If disabled, the pitch offset cannot be adjusted and will default to zero (standalone installation only). Enables and disables the pitch offset in normal mode. This setting is only present when the Installation Type setting is configured as a Standalone Unit.</p>
<p>Automatic Declutter</p>	<p>Enables and disables the automatic change from the HSI page to the PFD page when the aircraft enters an unusual pitch/roll attitude.</p>

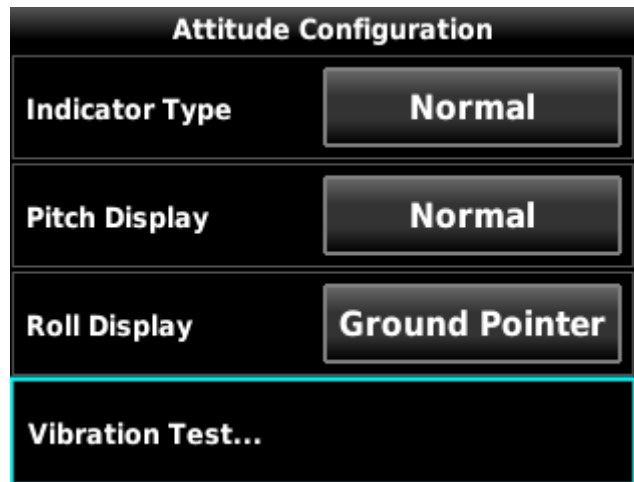

Figure 8-4 Attitude Configuration Page

8.4.3 Air Data Configuration Page

The Air Data Configuration page is used to configure user display preferences and to complete the post-installation calibration procedures.

Table 8-2 Air Data Configuration Settings

Configuration Setting	Description
Air Data Sensors	Select Disabled to disable the G5's internal air data sensors and hide airspeed, altitude, and vertical speed information on the PFD. This option is intended for single standalone G5 installations where the pitot/static inputs are not connected. This setting is only present when the Installation Type setting is configured as a Standalone Unit and the installation does not have an autopilot configured.
Vertical Speed Indicator	Configures the G5's PFD vertical speed indicator to display ± 1500 fpm, ± 2000 fpm, or ± 3000 fpm.
Calibrate Static Pressure	Performs a field calibration of the G5's static pressure sensor. Only required when the G5 has failed a periodic altimeter test. See Section 8.4.6.3 for more information.

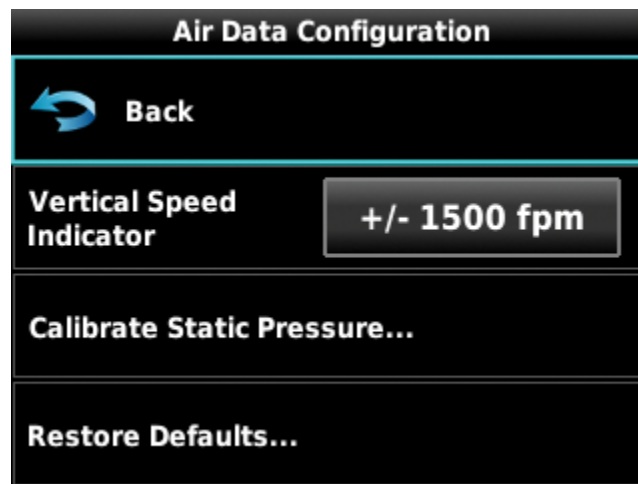

Figure 8-5 Air Data Configuration Page

8.4.4 Airspeed Configuration Page

This page allows for configuration of the reference speeds. The aircraft Vspeeds can be entered using the knob on the G5.

To clear a reference speed setting:

1. Highlight the desired reference speed setting.
2. Rotate the knob counterclockwise until a blank field is displayed.

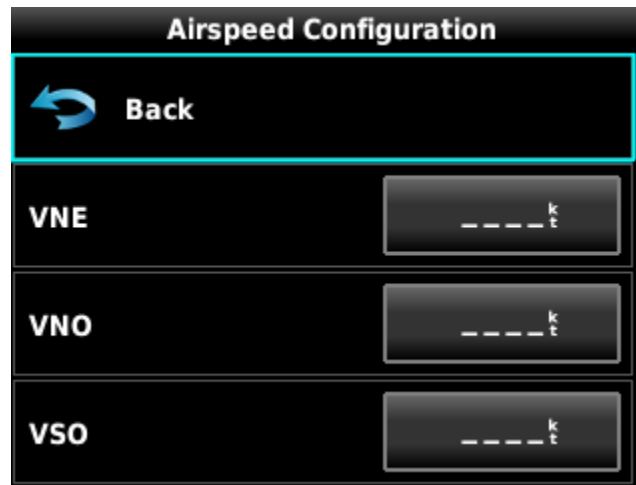

Figure 8-6 Airspeed Configuration Page

8.4.5 Magnetometer Configuration Page

The Magnetometer Configuration page is used to enable or disable the magnetometer function depending on whether an optional GMU 11 Magnetometer is connected to the G5.

Table 8-3 Magnetometer Configuration Settings

Configuration Setting	Description
Magnetometer	Select Disabled to disable the G5's optional magnetometer function. The Enabled option is intended for single standalone G5 installations that are connected to a GMU 11 Magnetometer.
Status	Indicates status of communication with GMU 11.
Orientation	Used to inform the G5 of the mounted orientation of a GMU 11 Magnetometer (optional). See Section 8.4.6.4 for detailed instructions.
Interference Test	Used to verify that no magnetic interference exists near the GMU 11 installation. See Section 8.4.6.5 for detailed instructions.
Calibrate Magnetometer	Used to calibrate the magnetometer in the mounted location/orientation. See Section 8.4.6.6 for detailed instructions.

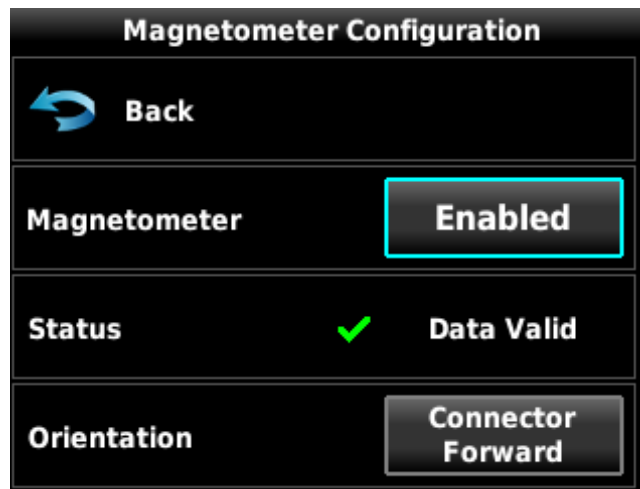

Figure 8-7 Magnetometer Configuration Page

8.4.6 G5 Post-Installation Calibration Procedures

After mechanical and electrical installation of the G5 has been completed, prior to operation, a set of post-installation calibration procedures must be carried out. Table 8-4 describes the required and optional calibration procedures.

Table 8-4 Post-Installation Calibration Procedure Summary

Calibration Procedure	Procedure Name	Procedure Description	Installations Requiring Procedure
A	Pitch/Roll Offset Compensation	Level aircraft	Procedure A is required for all installations
B	Engine Run-Up Vibration Test	Validate vibration characteristics of installation	Procedure B is required for all installations
C	Air Data Static Pressure Calibration	Altitude re-calibration	Procedure C is only used when the G5 has failed a periodic altimeter test
D	Magnetometer Unit Orientation	Configure magnetometer installation orientation	Procedure D is required for all GMU 11 installations
E	Magnetometer Interference Test	Validate no magnetic interference with GMU 11 Magnetometer	<p>Procedure E is required for initial installation verification.</p> <p>This test should also be repeated to verify all subsequent electrical changes associated with devices within 10 feet of the magnetometer. Such changes include, but are not limited to, wiring, shielding or grounding changes to any light, strobe, beacon or other electrical device located near or in the same wing as the magnetometer. Likewise, this test should also be repeated to verify all subsequent changes to materials within 10 feet of the magnetometer. Such changes include, but are not limited to, addition, removal or modification of ferrous or electrically conductive materials located near or in the same wing as the magnetometer unit.</p> <p>Garmin recommends this test be performed at least once every 12 months.</p>
F	Magnetometer Calibration Procedure	Compass rose taxi maneuver	<p>Procedure F is required for all installations.</p> <p>This calibration must be performed after every Pitch/Roll Offset Compensation and following a removal or replacement of the GMU 11, or degaussing of the area near the GMU 11 location.</p>

8.4.6.1 Calibration Procedure A: Pitch/Roll Offset Compensation



NOTE

This procedure requires orienting the aircraft to normal flight attitude. This can be done by using jacks or placing wood blocks under the nose-wheel, for example. As another example, if the number of degrees 'nose high' the aircraft flies in straight and level cruise is known, a digital level can be used to orient the aircraft to normal flight attitude prior to the calibration.



NOTE

The G5 must be installed to be level in pitch/roll within 30.0° of the aircraft in-flight level cruise attitude. In-flight level cruise attitude is not necessarily the same as the level reference provided by the manufacturer (such as fuselage longerons).

1. Select the Attitude Configuration page.
2. Select Calibrate Pitch/Roll.
3. Ensure that aircraft and the unit comply with all on-screen instructions, then select Start.



Figure 8-8 Calibration Page

4. A progress screen will then be displayed. There is a 30 second countdown timer for the procedure that resets when the aircraft moves.
5. When the calibration is complete, a successful status message will be displayed along with the new pitch and roll offsets.



NOTE

The pilot may adjust the displayed pitch attitude in normal mode. The maximum amount of pitch display adjustment available in normal mode is ±5.0°. This feature should not be used to compensate for a non-conforming installation that does not meet the requirements of the pitch/roll offset compensation calibration procedure.



NOTE

In a G3X system, or a non-G3X system with multiple G5 units, if the pitch/roll offset procedure is performed for one unit, it should be performed on all other G3X AHRS units or G5 units before moving the aircraft.

8.4.6.2 Calibration Procedure B: Engine Run-Up Vibration Test



NOTE

Calibration Procedure B is required for all installations to validate the vibration characteristics of the installation.

Passing the Engine Run-Up Vibration test does not remove the requirement to rigidly mount the G5. The Engine Run-Up Vibration Test is intended to help discover mounting issues but successful completion of the test does not validate the mounting of the G5, and does not account for all possible vibration profiles that may be encountered during normal aircraft operation

1. Select the Attitude Configuration page.
2. Select Vibration Test.
3. Ensure the aircraft complies with all on-screen instructions, then select Start.

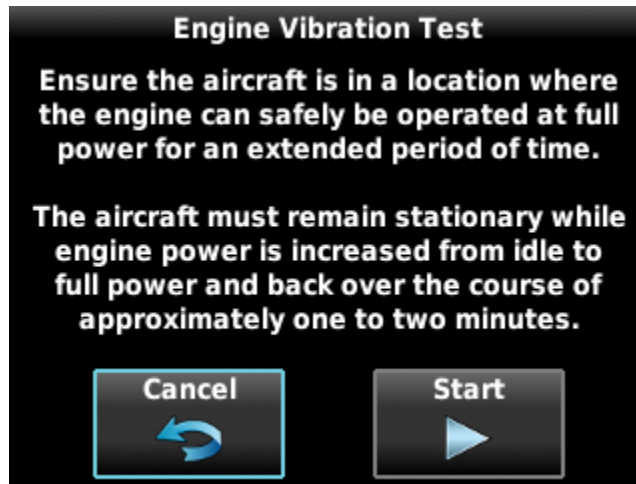

Figure 8-9 Vibration Test Page

4. Gradually increase engine power from idle to full power and back over the course of 1-2 minutes. A progress screen will be displayed showing the status of the test.
5. Select Done when the test has been completed. Passing results will be indicated by a green check mark and failures will be indicated by a red "X". If failures are indicated, repeat the test. If failures persist, the installation should be considered unreliable until the source of the vibration problem is identified and remedied. Record the out of range limit values for future reference.

The following are potential causes for failures of the engine run-up test:

- a) Excessive flexing of the G5 mechanical mounting with respect to airframe (see [Section 3.4.1](#) for applicable mounting requirements and instructions).
- b) Vibration or motion of the G5 caused by neighboring equipment and/or supports.
- c) Mounting of the G5 in a location that is subject to severe vibrations (e.g. close to an engine mount).
- d) Mounting screws and other hardware for G5 not firmly attached.
- e) Absence of recommended mounting supports.
- f) G5 connector not firmly attached to unit.
- g) Cabling leading to the G5 not firmly secured to a supporting structure.
- h) An engine/propeller combination that is significantly out of balance.



NOTE

In some aircraft, attempting the engine run-up test on a day with very strong and/or gusty winds may cause the test to occasionally fail. However, windy conditions should not be taken as evidence that the test would pass in calm conditions; an actual pass is required before the installation can be considered adequate.

8.4.6.3 Calibration Procedure C: Air Data Static Pressure Calibration

The Air Data Configuration page has a selection for static pressure calibration. This procedure is used to perform an altimeter re-calibration. The altitude pressure sensor used in the G5 is very low drift and does not typically require re-calibration.



NOTE

This calibration is only used when the G5 fails a periodic altimeter test and should only rarely, if ever, be used.

The static pressure calibration requires the use of a pressure control system (test set) with an altitude accuracy of at least ± 5 feet at sea level and ± 20 feet at 30,000 feet. It is necessary to re-calibrate to sea level (0 feet), 10,000 feet, 20,000 feet, and optionally to 30,000 feet. The operator is allowed to finish the calibration at the end of the 20,000-foot calibration if the 30,000-foot calibration is not desired.



CAUTION

To avoid damaging the G5 pressure sensors, both the pitot and static ports must be connected to the test set.

1. Select the Air Data Configuration page.
2. Select Calibrate Static Pressure.
3. Ensure all on-screen instructions have been complied with, then select Start.

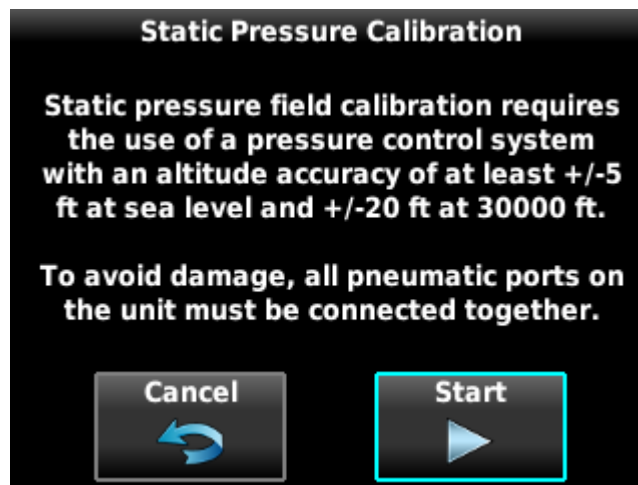

Figure 8-10 Static Pressure Calibration Page

4. At each calibration point the display will present a screen indicating the pressure altitude to set. Once the altitude is set, select Ready to calibrate this pressure.
5. During the calibration at each pressure, the pressure must be held constant for 30 seconds for the calibration step to be successful. The calibration may be cancelled at any point should the test setup require adjustment before repeating. A progress screen will be displayed showing the status of the test.
6. Select Done when the static pressure calibration is successfully completed.

8.4.6.4 Calibration Procedure D: Magnetometer Unit Orientation

1. Select the Magnetometer Configuration page.
2. Ensure that the Status field displays Data Valid.
3. Select the Orientation of the GMU 11 in the installation using the on-screen instructions as a guide.

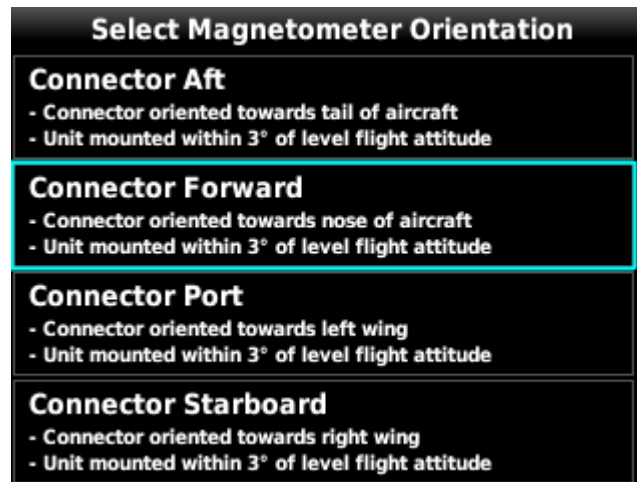

Figure 8-11 Select Magnetometer Orientation

4. Ensure that the correct orientation is now displayed on the Magnetometer Configuration page.

8.4.6.5 Calibration Procedure E: Magnetometer Interference Test



NOTE

Calibration Procedure E is required for all installations that include a GMU 11 in order to validate the magnetic characteristics of the installation.

1. Select the Magnetometer Configuration page.
2. Select Interference Test.
3. Ensure that the aircraft complies with all on-screen instructions, then select Next.

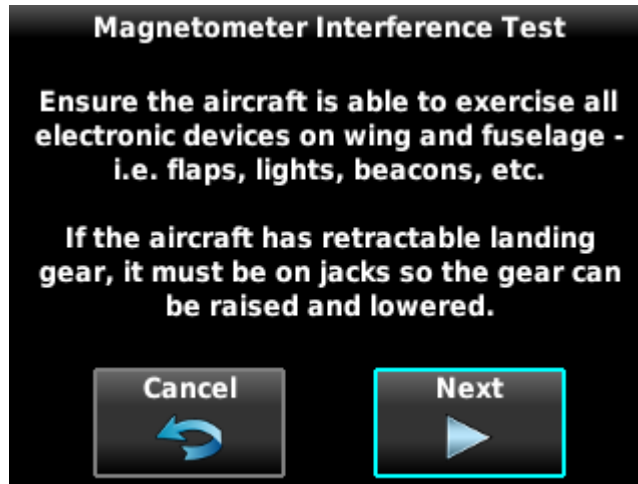

Figure 8-12 Magnetometer Interference Test

4. Ensure that the aircraft has been properly prepared per the on-screen instructions. See Table 8-5 for a sample test sequence. Select Start to begin the test.

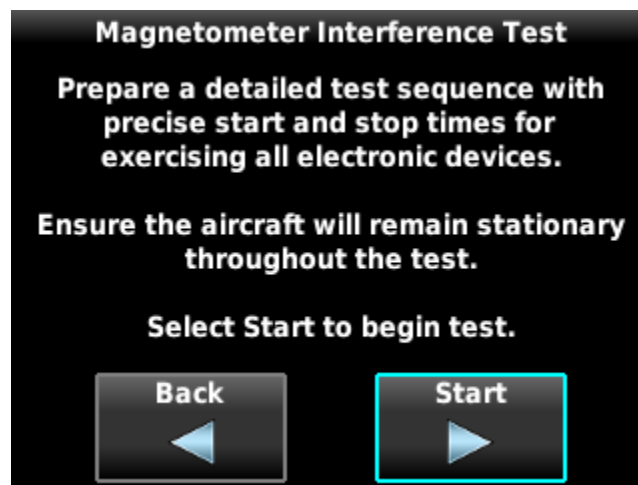

Figure 8-13 Magnetometer Interference Test

- The operator should carry out the actions called for in the prepared test sequence. During calibration, a real-time value is displayed that represents the current magnetic field strength as a percentage of the maximum limit.

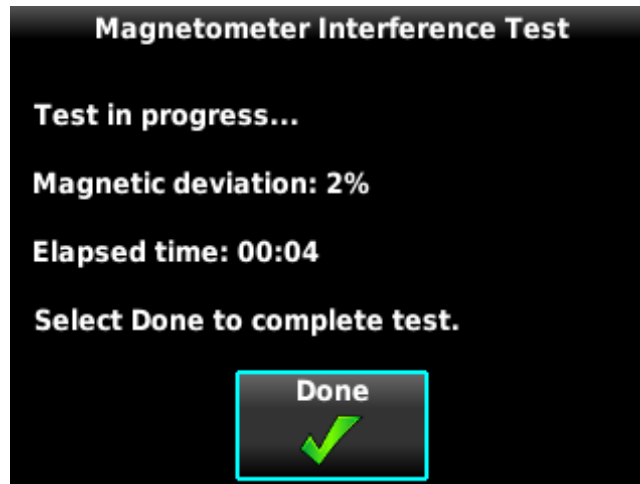

Figure 8-14 Magnetometer Interference Test In Progress



NOTE

It is important that all actions are carried out in the order and at the precise elapsed time as specified in the prepared test sequence.

- After completing the prepared test sequence, select Done. The test status will indicate whether the interference test passed or failed. The worst case magnetic deviation value will indicate the test margins. Values less than or equal to 100% constitute a pass and greater than 100% constitute a fail.

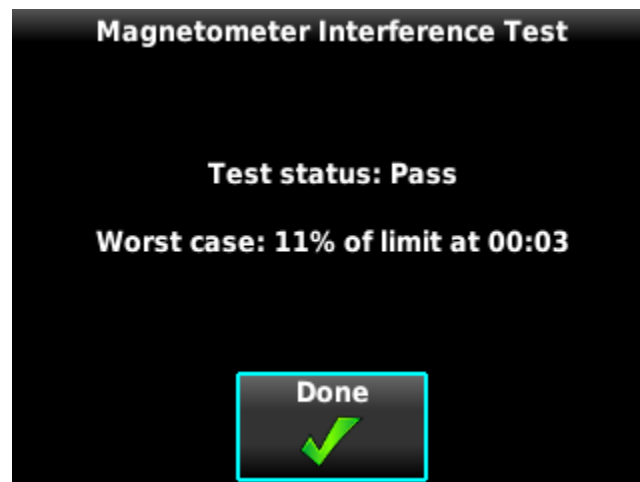

Figure 8-15 Magnetometer Interference Test Passed

Table 8-5 Magnetometer Interference Test Sequence Example

Elapsed Time Since Start of Test (min:sec)	Action
0:00	Test begins
0:10	Aileron full right
0:20	Aileron full left
0:30	Aileron level
0:40	Elevator up
0:50	Elevator down
1:00	Elevator level
1:20	Rudder left
1:40	Rudder right
1:50	Rudder center
2:00	Flaps down
2:10	Flaps up
2:20	Autopilot on
2:30	Autopilot off
2:40	Landing gear up
2:50	Landing gear down
3:00	Speed brake up
3:10	Speed brake down
3:20	Navigation lights on
3:30	Navigation lights off
3:40	Landing lights on
3:50	Landing lights off
4:00	Taxi lights on
4:10	Taxi lights off
4:20	Landing and taxi lights on
4:30	Landing and taxi lights off
4:40	Strobes on
4:50	Strobes off
5:00	Recognition lights on
5:10	Recognition lights off
5:20	Turn on all wing-tip lights simultaneously (this will typically include navigation lights, recognition lights, and strobe)
5:30	Turn off all wing-tip lights simultaneously
5:40	Beacon on
5:50	Beacon off
6:00	Pitot heat on
6:10	Pitot heat off
6:20	End of test

If the test fails, the installation should be considered unreliable until the source of magnetic interference is identified and remedied. The magnetometer interference test must be repeated until passed. When the magnetometer interference test fails, record the three greatest magnetic deviation values and their corresponding timestamps. A maximum deviation value greater than 100% of the total limit indicates a problem that must be resolved. Compare the corresponding timestamps with the prepared test sequence to identify which action produced the problem. Contact Garmin for assistance in resolving the problem.



NOTE

Two common reasons for a failed magnetometer interference test are:

- 1) New equipment is installed in close proximity to the GMU 11 Magnetometer.*
- 2) An existing or new electronic device has become grounded through the aircraft structure instead of via the proper ground wire in a twisted shielded pair.*

8.4.6.6 Calibration Procedure F: Magnetometer Calibration Procedure



NOTE

Calibration Procedures A, B, and C must be successfully completed prior to Calibration Procedure F.



NOTE

Calibration Procedure F must be carried out at a location that is determined to be free of magnetic disturbances, such as a compass rose. Attempting to carry out this maneuver on a typical ramp area will not yield a successful calibration. The accuracy of the magnetometer cannot be guaranteed if this calibration is not performed in a magnetically clean location.

Taxi the aircraft to a site that has been determined to be free of magnetic disturbances. Ensure that there are no nearby magnetic materials on or near the perimeter of the site. If unavoidable, maneuver the aircraft to keep the magnetometer from passing within 20 feet (6.1 meters) of such objects. Additionally, ensure that vehicles or other aircraft are an adequate distance (40 feet [12.2 meters]) away from the aircraft during the calibration procedure.

At the site, align the aircraft to a heading of magnetic north ($\pm 5^\circ$). It is best to offset the aircraft position to the west of the north/south axis to provide space for the aircraft to turn clockwise around the site during the procedure as indicated in Figure 8-16.

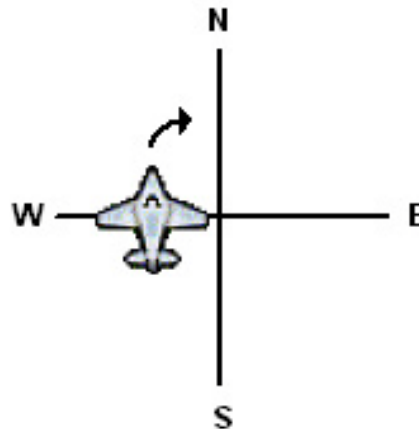

Figure 8-16 Aircraft Alignment

With the aircraft stationary, initiate the magnetometer calibration procedure as follows:

1. Select the Magnetometer Configuration page.
2. Select Calibrate Magnetometer.
3. Ensure that all on-screen instructions have been complied with, then select Next.



Figure 8-17 Magnetometer Calibration Page

4. Ensure that all on-screen instructions have been complied with, then select Next.

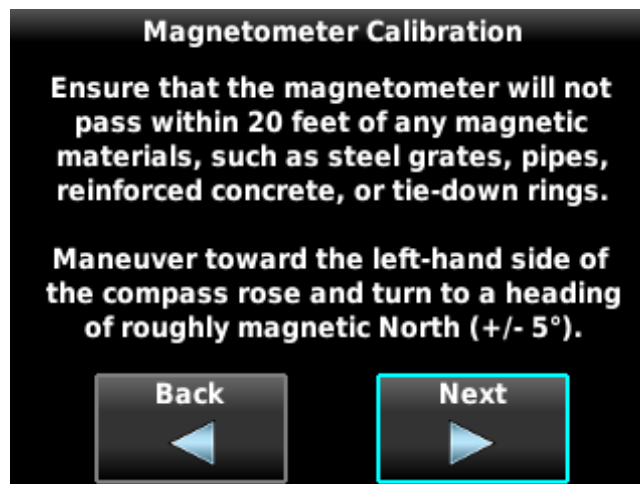

Figure 8-18 Magnetometer Calibration Page

5. Ensure that all on-screen instructions have been complied with, then select Start.



Figure 8-19 Magnetometer Calibration Page

6. Follow the on-screen instructions by holding the current aircraft position. During this time the magnetometer will be calibrating the magnetic environment of the installation. The dots at the end of the text will be removed as this step of the test progress.

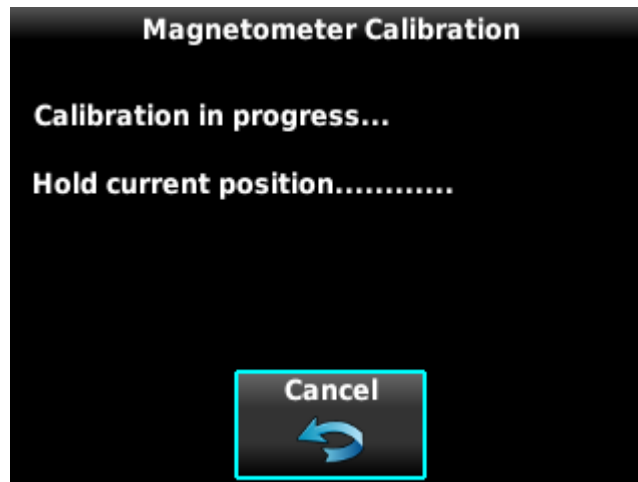

Figure 8-20 Magnetometer Calibration Page

7. After holding the starting position, continue following the on-screen instructions by slowly turning the aircraft to the right. The dots at the end of the text will be removed as the aircraft rotates 30°.
8. Continue following the on-screen instructions until the calibration is completed. The turn and hold procedure detailed above will repeat for a total of 12 cycles before the calibration is complete (resulting in the aircraft completing a full circle of rotation).
9. If the calibration is successful, a passing status message will be displayed. The calibration will abort if it cannot be successfully completed. Ensure all on-screen instruction are followed and repeat the test (if necessary) to obtain a successful calibration.

8.4.7 Flight Controls Configuration Page

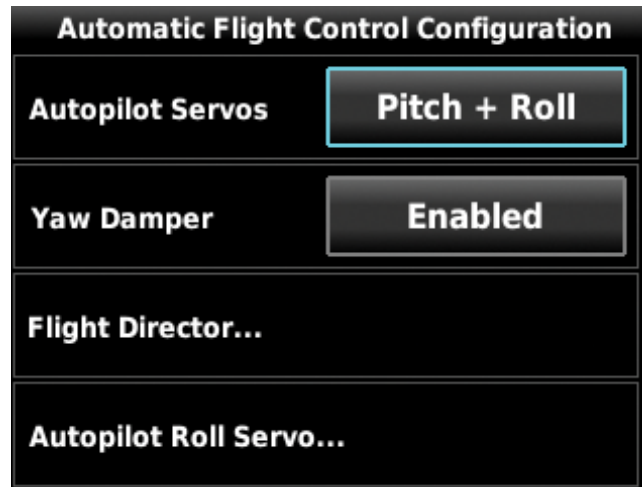

Figure 8-21 Flight Controls Configuration Page

8.4.7.1 General Autopilot Description

The GSA 28 based autopilot system is a fully integrated, high performance autopilot that can control up to three axes of an aircraft (refer to the G3X Installation Manual for GSA 28 installation information). Each GSA 28 servo is also capable of managing the trim control for its axis. The following four subsections (roll, pitch, yaw, and trim) are provided to aid the pilot/installer in understanding/configuring the Garmin GSA 28 autopilot system.



NOTE

A GMC 305/307 is required to use the G5 autopilot controls.

Roll Servo

All GSA 28 autopilot systems require a servo to control the roll axis of an aircraft. A single axis GSA 28 installation that controls only the roll axis is sometimes referred to as a “wing-leveler”.

The roll servo follows roll steering commands from the G5 so the airplane will hold a desired roll angle, follow a desired heading/track, or follow the lateral component of a flight plan.

During the flight test phase of the autopilot checkout, the roll servo aggressiveness will be adjusted to get the desired in-flight performance. The roll servo gain setting is used to set the aggressiveness of the roll servo. A larger number will cause the roll servo to more aggressively control the aircraft and a smaller number will cause the roll servo to less aggressively control the aircraft.

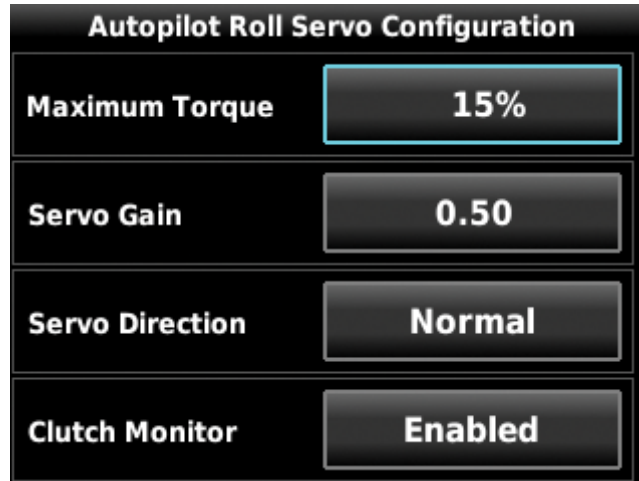

Figure 8-22 Roll Servo Configuration Page

Pitch Servo

Most GSA 28 autopilot systems consist of both a roll and pitch servo allowing for full 2-axis control of the aircraft.

The pitch servo follows vertical guidance commands from the G5 so the airplane will hold a desired pitch angle, vertical speed, airspeed, or altitude, or follow the vertical component of a flight plan.

Vertical control of the aircraft is all based on controlling the pitch angle with two additional sub-modes for vertical speed and airspeed. What this means is that the basic pitch mode performance must be properly adjusted before changing settings that adjust the vertical speed and airspeed based modes.



NOTE

Ensure pitch mode functionality is properly adjusted before attempting to adjust vertical speed or airspeed mode performance.

During the flight test phase of the autopilot checkout, the pitch servo aggressiveness will be adjusted to get the desired in-flight performance. The pitch servo gain setting is used to set the aggressiveness of the pitch servo. A larger number will cause the pitch servo to more aggressively control the aircraft, and a smaller number will cause the pitch servo to less aggressively control the aircraft.



Figure 8-23 Pitch Servo Configuration Page

Yaw Damper

The GSA 28 autopilot system can be expanded to support a yaw damper. The yaw damper will control the rudder to compensate or remove aircraft body yaw (tail wagging). The yaw damper will also try to null the lateral acceleration (center the ball) over the long term. The ball centering portion of the yaw damper is not a replacement for proper rudder trim.



NOTE

Yaw damper functionality requires a GMC 305/307 mode control panel with a YD button.

During the flight test phase, the yaw damper is configured and set up after the basic two axis pitch and roll performance has been properly configured. This is done so the pilot can focus on properly adjusting the performance of each individual component of the autopilot system without trying to tune them all at once.



NOTE

Ensure basic autopilot functionality is properly adjusted before using the yaw damper.

During the flight test phase of the autopilot checkout, the yaw servo aggressiveness will be adjusted to get the desired in-flight performance. The yaw servo gain setting is used to set the aggressiveness of the yaw servo. A larger number will cause the yaw servo to more aggressively control the aircraft, and a smaller number will cause the yaw servo to less aggressively control the aircraft.



Figure 8-24 Yaw Damper Configuration Page

Trim Control

The GSA 28 autopilot servos can be used to control the trim system in an aircraft. When the autopilot is disengaged, the servos can adjust the trim speed based on the current aircraft airspeed. This allows the trim to run slower at high airspeeds and faster at low airspeeds. When the autopilot is engaged in the air, the servos can adjust the trim control to minimize the force on the primary controls. This helps ensure the aircraft will be properly trimmed when the autopilot is later disengaged.

During the flight test phase, the trim system is configured and set up after the primary autopilot performance has been properly configured. This is done so the pilot can focus on properly adjusting the performance of the primary autopilot system without having the autotrim functionality interfere.



NOTE

Ensure basic autopilot functionality is properly adjusted before enabling trim control for any servo.

8.4.7.2 On-Ground Initial Checkout



NOTE

The following post installation checkout must be followed after every completed installation. These steps should be followed when using a Garmin mounting kit or non-Garmin mounting parts to install the GSA 28.

After mounting the GSA 28, please complete the following steps prior to completing the first flight with the GSA 28.

1. Verify that the flight controls can move from stop to stop without binding or interference. Check that the GSA 28 output mechanism and added linkage do not come in contact with any part of the airframe while traveling through its full range of motion.
2. Verify that the travel of the flight controls is being limited by the airplane's primary stops and not the secondary stops provided by the GSA 28 stop bracket.
3. Ensure the structural integrity of the mounting bracket is adequate for the application and well secured to the airframe. Bracket deflection caused by normal servo loading and aircraft acceleration/vibration should be minimal. Verify there are no cracks or sharp inside corners that could lead to fatigue failures.
4. Verify the fasteners used to mount the servo to the airframe are installed and have been tightened.
5. Make sure the AP DISC wire is correctly wired and tested.
6. If powering the servo through a "pullable" circuit breaker (recommended), ensure the circuit breaker is both accessible and easily identifiable to the pilot.
7. Repeat steps 1-6 for all GSA 28 servos in the aircraft.

8.4.7.3 On-Ground Setup

Servo Wiring Checkout

The first phase of setting up the autopilot system is to verify the proper wiring of the GSA 28 servos while on the ground.

1. If the installation is a 1-axis (roll only) autopilot, use the Flight Controls Configuration page to configure the autopilot servos for roll only.
2. If the installation is a 2-axis (pitch and roll) autopilot, use the Flight Controls Configuration page to configure the autopilot servos for pitch and roll.
3. If the installation is a 3-axis (pitch, roll, and yaw) autopilot, use the Flight Controls Configuration page to configure the autopilot servos for pitch and roll and enable the yaw damper.
4. Ensure the pitch, roll, and yaw servos are properly communicating by checking the Device Information page. Each device should have a green check mark next to it.

Device Information		
<input checked="" type="checkbox"/>	ROLL	GSA 28 3.20
<input checked="" type="checkbox"/>	PITCH	GSA 28 3.20
<input checked="" type="checkbox"/>	YD	GSA 28 3.20
<input checked="" type="checkbox"/>	GMC	GMC 305 2.00

Figure 8-25 Device Information Page

5. Select the Autopilot Roll Servo Configuration page and verify the proper trim activity with the servo connected to an auxiliary trim motor.

Autopilot Roll Servo Configuration	
Maximum Torque	15%
Servo Gain	0.50
Servo Direction	Normal
Clutch Monitor	Enabled

Figure 8-26 Autopilot Roll Servo Configuration Page

- a) Center the aileron trim switch to input no trim command. Verify the aileron trim switch is not moving. Verify the roll servo is properly indicating no trim activity.
 - b) Use the aileron trim switch to input a roll right trim command. Verify the aileron trim switch properly moves for roll right trim. Verify the roll servo is properly indicating roll right trim activity.
 - c) Use the aileron trim switch to input a roll left trim command. Verify the aileron trim switch properly moves for roll left trim. Verify the roll servo is properly indicating roll left trim activity.
 - d) If the aileron trim response is reversed, select Reverse for the Trim Motor Direction, then repeat all of step 5.
6. Select the Autopilot Pitch Servo Configuration page and verify the proper trim activity with the servo connected to an auxiliary trim motor.



Figure 8-27 Autopilot Pitch Servo Configuration Page

- a) Center the elevator trim switch to input no trim command. Verify the elevator trim switch is not moving. Verify the pitch servo is properly indicating no trim activity.
- b) Use the elevator trim switch to input a nose up trim command. Verify the elevator trim switch properly moves for nose up trim. Verify the pitch servo is properly indicating nose up trim activity.
- c) Use the elevator trim switch to input a nose down trim command. Verify the elevator trim switch properly moves for nose down trim. Verify the pitch servo is properly indicating nose down trim activity.
- d) If the elevator trim response is reversed, select Reverse for the Trim Motor Direction, then repeat all of step 6.

7. Select the Yaw Damper Configuration page and verify the proper trim activity with the servo connected to an auxiliary trim motor.



Figure 8-28 Yaw Damper Configuration Page

- a) Center the aircraft rudder trim switch to input no trim command. Verify the rudder trim switch is not moving. Verify the yaw servo is properly indicating no trim activity.
 - b) Use the rudder trim switch to input a yaw right trim command. Verify the rudder trim switch properly moves for yaw right trim. Verify the yaw servo is properly indicating yaw right trim activity.
 - c) Use the rudder trim switch to input a yaw left trim command. Verify the rudder trim switch properly moves for yaw left trim. Verify the yaw servo is properly indicating yaw left trim activity.
 - d) If the rudder trim response is reversed, select Reverse for the Trim Motor Direction, then repeat all of step 7.
8. Select the Autopilot Roll Servo Configuration page to configure the servo direction.
 - a) With the Servo Direction set to Normal, the servo arm should move clockwise to cause a bank left aileron movement and the servo arm should move counterclockwise to cause a bank right aileron movement.
 - b) With the Servo Direction set to Reverse, the servo arm should move clockwise to cause a bank right aileron movement and the servo arm should move counterclockwise to cause a bank left aileron movement.
 9. Select the Autopilot Pitch Servo Configuration page to configure the servo direction.
 - a) With the Servo Direction set to Normal, the servo arm should move clockwise to cause a nose down elevator movement and the servo arm should move counterclockwise to cause a nose up elevator movement.
 - b) With the Servo Direction set to Reverse, the servo arm should move clockwise to cause a nose up elevator movement and the servo arm should move counterclockwise to cause a nose down elevator movement.

10. Select the Yaw Damper Configuration page to configure the servo direction.
 - a) With the Servo Direction set to Normal, the servo arm should move clockwise to cause a nose left rudder movement and servo arm should move counterclockwise to cause a nose right rudder movement.
 - b) With the Servo Direction set to Reverse, the servo arm should move clockwise to cause a nose right rudder movement and the servo arm should move counterclockwise to cause a nose left rudder movement.
11. Set the Trim Motor Control to Disabled using the Autopilot Roll Servo, Autopilot Pitch Servo, and Yaw Damper Configuration pages as applicable.

**NOTE**

Initial autopilot tuning is done with the trim control disabled to avoid the autotrim function from interfering with the initial autopilot tuning.

- a) By disabling the trim motor control, this will disable autotrim and airspeed scheduled trim, but the pilot can still control trim in the aircraft using the normal manual electric trim inputs. Autotrim and airspeed scheduled trim will be setup later in the autopilot setup procedure.
12. The proper minimum and maximum airspeed limits for the pitch servo can be set in the Autopilot Pitch Servo Configuration page. The pitch servo will lower or raise the nose of the aircraft to keep the aircraft within these airspeed limits.
 - a) The minimum airspeed limit should be set above the stall speed of the aircraft with some margin.
 - b) The maximum airspeed limit should be set below the never exceed speed of the aircraft with some margin.

8.4.7.4 On-Ground Autopilot Setup

The next phase of setting up the Garmin autopilot system is to verify the proper functionality of the autopilot system on the ground in normal mode. This phase of the checkout requires a valid ground track and pitch output from the G5. This means the post installation procedures must have already been completed on the G5 before performing the on-ground autopilot normal mode checkout.



NOTE

If the installation does not include a magnetometer, HDG mode will be replaced by TRK mode. All other instructions are applicable to either type of installation.

1. Leave the autopilot disengaged and verify the controls can be manipulated smoothly with no control system binding.
2. Engage the autopilot in HDG/PIT mode and command a nose down, left bank.
 - a) Press the AP button on the GMC 305/307.
 - b) Press the HDG button on the GMC 305/307.
 - c) Push the knob on the G5 to access the menu.
 - d) Select Track from the menu on the G5.
 - e) Push and hold the knob on the G5 to center the HDG bug.
 - f) Rotate the knob on the G5 counterclockwise to command a left turn.
 - g) Rotate the wheel on the GMC 305/307 down to command a pitch downward.
3. Verify the stick properly moves toward the nose and toward the left wing smoothly with no control system binding.
4. Engage the autopilot in HDG/PIT mode and command a nose down, right bank.
 - a) Press the AP button on the GMC 305/307.
 - b) Press the HDG button on the GMC 305/307.
 - c) Push the knob on the G5 to access the menu.
 - d) Select Track from the menu on the G5.
 - e) Push and hold the knob on the G5 to center the HDG bug.
 - f) Rotate the knob on the G5 clockwise to command a right turn.
 - g) Rotate the wheel on the GMC 305/307 down to command a pitch downward.
5. Verify the stick properly moves toward the nose and toward the right wing smoothly with no control system binding.

6. Engage the autopilot in HDG/PIT mode and command a nose up, right bank.
 - a) Press the AP button on the GMC 305/307.
 - b) Press the HDG button on the GMC 305/307.
 - c) Push the knob on the G5 to access the menu.
 - d) Select Track from the menu on the G5.
 - e) Push and hold the knob on the G5 to center the HDG bug.
 - f) Rotate the knob on the G5 clockwise to command a right turn.
 - g) Rotate the wheel on the GMC 305/307 up to command a pitch upwards.
7. Verify the stick properly moves toward the tail and toward the right wing smoothly with no control system binding.
8. Engage the autopilot in HDG/PIT mode and command a nose up, left bank.
 - a) Press the AP button on the GMC 305/307.
 - b) Press the HDG button on the GMC 305/307.
 - c) Push the knob on the G5 to access the menu.
 - d) Select Track from the menu on the G5.
 - e) Push and hold the knob on the G5 to center the HDG bug.
 - f) Rotate the knob on the G5 counterclockwise to command a left turn.
 - g) Rotate the wheel on the GMC 305/307 up to command a pitch upwards.
9. Verify the stick properly moves toward the tail and toward the left wing smoothly with no control system binding.
10. If the stick position does not move in the correct direction, correct the roll and pitch servo directions documented in the Servo Wiring Checkout.
11. Engage the autopilot and verify it can be overpowered in both the pitch and roll axes. If the autopilot cannot be overpowered, use the Autopilot Roll Servo and Autopilot Pitch Servo Configuration pages to reduce the Maximum Torque setting for the associated servo.
12. Engage the autopilot and verify that it properly disconnects with a short press and release of the CWS/DISCONNECT button.

8.4.7.5 On-Ground Yaw Damper Setup

The next phase of setting up the Garmin autopilot system is to verify the proper functionality of the yaw damper system on the ground in normal mode. This phase of the checkout requires a valid output from the G5. This means the post installation procedures must have been completed on the G5 before performing the on-ground autopilot normal mode checkout.

1. Leave the yaw damper disengaged and verify the rudder pedals can be manipulated smoothly with no control system binding.
2. Engage the autopilot in YD mode by pressing the YD button on the GMC 305/307.
3. Verify the rudder properly moves to the correct direction by standing by the tail of the aircraft, facing the vertical stabilizer, and pushing on the fuselage. The rudder should move AWAY from you (the rudder should move in the same direction that the rear fuselage is moving):
 - a) If the rudder does not move the correct direction, correct the yaw servo direction documented in the Servo Wiring Checkout.
4. Engage the yaw damper and verify it can be overpowered in the yaw axis using rudder pedal inputs. If the autopilot cannot be overpowered, use the Yaw Damper Configuration page to reduce the Maximum Torque setting for the yaw damper servo.
5. The CWS/DISCONNECT input can optionally be connected to the Yaw Damper. If this connection was made, engage the yaw damper and verify that it properly disconnects with a short press and release of the CWS/DISCONNECT button.

8.4.7.6 In-Air Autopilot Setup

The next phase of setting up the Garmin autopilot system is to verify and tune the proper functionality of the autopilot system while airborne. Refer to [Section 8.4.7.1](#) for general autopilot use and functionality.



WARNING

This stage of the flight test involves allowing the GSA 28 autopilot servos to manipulate the flight control surfaces of the aircraft. Extreme caution should be used during the initial engagement of the autopilot system. The pilot should always have easy access to the autopilot disconnect button to disconnect the autopilot and take control of the aircraft at anytime.

At a minimum, please follow the following safety guidelines before the initial autopilot engagement:

- Quick access to autopilot disconnect
- Safe altitude above and away from all terrain and obstacles
- No air traffic in the area
- Safe airspeed below maneuvering speed (VA)



NOTE

If desired, in the following procedures, the expert configurations can be accessed from the Autopilot Roll Servo, Autopilot Pitch Servo, and Yaw Damper Configuration pages.

Roll Servo

1. Use the Setup page in normal mode to adjust the roll servo gain setting.
 - a) Engage the autopilot in ROL/PIT mode with the aircraft approximately level.

- i. Press the AP button on the GMC 305/307 to engage the AP.
 - ii. Press the YD button on the GMC 305/307 to disengage the YD.
 - b) Press the knob of the G5 to access the menu.
 - c) Select Setup from the menu.
 - d) Select the Autopilot Roll Servo page.
 - e) Select the Servo Gain entry.
 - f) Adjust the servo gain so that the aircraft properly responds to the roll guidance from the flight director.
 - i. Overpower the autopilot to fly away from the current flight director commanded roll.
 - ii. Release the controls and monitor the autopilot response and closure back to the commanded roll.
 - iii. Set the servo gain higher to make the autopilot more aggressive.
 - iv. Set the servo gain lower to make the autopilot less aggressive.
2. The roll servo has additional expert configurations that can be adjusted to achieve the desired lateral mode performance. These settings are detailed in [Table 8-7](#) and should only be adjusted after studying the descriptions to properly understand their effect on the roll servo.

Pitch Servo

1. Use the Setup page in normal mode to adjust the pitch servo gain setting. It is important to ensure proper autopilot response in PIT mode before proceeding to adjust other autopilot pitch axis gains and modes (including ALT and VS modes).
 - a) Engage the autopilot in ROL/PIT mode with the aircraft approximately level.
 - i. Press the AP button on the GMC 305/307 to engage the AP.
 - ii. Press the YD button on the GMC 305/307 to disengage the YD.
 - b) Press the knob on the G5 to access the menu.
 - c) Select Setup from the menu.
 - d) Select the Autopilot Pitch Servo page.
 - e) Select the Servo Gain entry.
 - f) Adjust the servo gain so that the aircraft properly responds to the pitch guidance from the flight director.
 - i. Overpower the autopilot to fly away from the current flight director commanded pitch.
 - ii. Release the controls and monitor the autopilot response and closure back to the commanded pitch.
 - iii. Set the servo gain higher to make the autopilot more aggressive.
 - iv. Set the servo gain lower to make the autopilot less aggressive.
2. The pitch servo has additional expert configurations that can be adjusted to achieve the desired vertical mode performance. These settings are detailed in [Table 8-8](#) and should only be adjusted after studying the descriptions to properly understand their effect on the pitch servo.

Pitch Servo Gain

The pitch servo gain settings should be configured only after the pitch/roll servo max torque and servo gains have been set per the preceding pages.

The minimum maximum airspeed limit entries set the limits of the autopilot vertical authority. The autopilot will limit the pitch control to stay within these airspeed limits.

The vertical speed gain entry is one of the most important gains in the system since it controls the behavior of the VNAV, ALT, and VS modes and also largely determines how well the plane flies approaches with vertical guidance.

The vertical speed gain is adjusted in a very similar manner to the pitch servo gain. Engage the autopilot in ROL/VS mode in level flight (vertical speed approximately zero).

Adjust the vertical speed gain so that the aircraft properly responds to the VS guidance from the flight director.

1. Overpower the autopilot to fly away from the current flight director commanded vertical speed.
2. Release the controls and monitor the autopilot response and closure back to the commanded vertical speed.
3. Set the vertical speed gain higher to make the autopilot more aggressive if it feels “lazy” or not as responsive as desired.
4. Set the vertical speed gain lower to make the autopilot less aggressive if the control is too “harsh” or more responsive than desired.

The vertical acceleration gain can often be left set at 1.00, but can be used to improve altitude captures when climbing or descending in VS or VNAV mode.

1. Climb to an altitude target in VS mode and observe the altitude capture.
2. Set the vertical acceleration gain higher if the aircraft objectionably overshoots the altitude target before leveling off at the correct altitude.
3. Set the vertical acceleration gain lower if the aircraft objectionably undershoots the altitude target before leveling off at the correct altitude.

Similar to the vertical speed gain, the airspeed gain can be used to improve airspeed hold performance when needed.

Pitch Gain has advanced and expert configurations that can be adjusted to achieve the desired performance. These settings are detailed in [Table 8-8](#) and should only be adjusted after studying the descriptions to properly understand their effect on pitch gain.

Yaw Damper Setup

The next phase of setting up the Garmin yaw damper system is to verify and tune the proper functionality of the yaw damper system in the air.



WARNING

This stage of the flight test involves allowing the GSA 28 autopilot servos to manipulate the flight control surfaces of the aircraft. Extreme caution should be used during the initial engagement of the autopilot system. The pilot should always have easy access to the autopilot disconnect button to disconnect the autopilot and take control of the aircraft at anytime.

At a minimum, please follow the following safety guidelines before the initial autopilot engagement:

- Quick access to autopilot disconnect
 - Safe altitude above and away from all terrain and obstacles
 - No air traffic in the area
 - Safe airspeed below maneuvering speed (VA)
1. Use the Setup page in normal mode to adjust the yaw damper gain setting.
 - a) Press the knob on the G5 to access the menu.
 - b) Select Setup from the menu.
 - c) Select the Yaw Damper page.
 - d) Select the Servo Gain entry.
 - e) Adjust the servo gain so that the aircraft properly responds to the yaw body rates (tail wagging).
 - i. Engage the autopilot in LVL mode with the aircraft approximately level.
 - ii. Press the LVL button on the GMC 305/307 to engage the AP in LVL mode.
 - iii. Press the YD button on the GMC 305/307 to disengage the YD.
 - iv. Fly a yaw doublet and engage the YD as the ball swings through the center.
 1. Use the right foot rudder to swing the ball left.
 2. Use the left foot rudder to swing ball back right.
 3. Engage the yaw damper by pressing the YD button on the GMC 305/307 as the ball swings through the center.
 4. Set the servo gain so the established yaw body rate from the yaw doublet is properly dampened out.
 - a) Set the servo gain higher to make the yaw damper more aggressive (if needed).
 - b) Set the servo gain lower to make the yaw damper less aggressive (if needed).
 2. The yaw servo has additional expert configurations that can be adjusted to achieve the desired yaw damping performance. These settings are detailed in [Table 8-9](#) and should only be adjusted after studying the descriptions to properly understand their effect on the yaw servo.

8.4.7.7 On-Ground Trim System Setup

After setting up and testing the GSA 28 based autopilot and yaw damper systems, the pilot can configure the trim system.

1. Set the Trim Motor Control to Enabled using the Autopilot Roll Servo, Autopilot Pitch Servo, and Yaw Damper Configuration pages for all servos that are connected to auxiliary trim motors.
 - a) The recommended setting for the Fastest Trim Motor Speed is 100% (this value will be adjusted during the in-air setup).
 - b) The recommended setting for the Slowest Trim Motor Speed is 25% (this value will be adjusted during the in-air setup).



NOTE

The Maximum Trim Run Time entry allows optional configuration of a time limit for use with a manual electric trim. When the manual trim input switch is pressed, the electric trim motor will stop running after the time limit expires, and will not run again until the trim input switch is released and pressed again. This can help prevent "trim runaway" caused by a stuck trim input switch. If the maximum trim motor run time is not set, the electric trim motor will run indefinitely as long as the manual trim input switch is held. Trim run time has no effect on auto trim.

2. Return to the Flight Controls Configuration page to set the airspeed thresholds for the fastest and slowest trim movement.
 - a) The recommended setting for the Trim Low Airspeed Threshold is the airspeed typically used for cruise flight.
 - b) The recommended setting for the Trim High Airspeed Threshold is the airspeed typically used to fly the normal aircraft landing pattern.
3. Re-verify proper trim movement described in [Section 8.4.7.3](#).

8.4.7.8 In-air Trim System Setup

The next phase of setting up the GSA 28 based trim control system is to verify and set the proper functionality of the trim system in the air. Refer to [Section 8.4.7.1](#) for general autopilot use and functionality.



WARNING

This stage of the flight test involves allowing the GSA 28 autopilot servos to manipulate the flight control surfaces of the aircraft. Extreme caution should be used during this phase of the flight test. The pilot should always have easy access to the autopilot disconnect button to disconnect the autopilot and take control of the aircraft at anytime.

At a minimum, please follow the following safety guidelines before the initial autopilot engagement:

- Quick access to autopilot disconnect
 - Safe altitude above and away from all terrain and obstacles
 - No air traffic in the area
 - Safe airspeed below maneuvering speed (VA)
1. Use the Setup page in normal mode to adjust the trim motor speed to get the desired manual electric trim response.
 - a) Press the knob on the G5 to access the menu.
 - b) Select Setup from the menu.
 - c) Note the low and high airspeed threshold settings on this page.
 - d) Select the Autopilot Roll Servo, Autopilot Pitch Servo, or Yaw Damper pages as applicable.
 - e) Adjust the trim motor speeds at the two airspeed thresholds to get a desirable trim response.
 - i. Trim aircraft using manual electric trim inputs
 - ii. Trim response should not be overly slow
 - iii. Trim response should not be overly fast

8.4.7.9 Autopilot Configuration Options

The installer needs to make the following autopilot configuration selections when setting up the GSA 28 based autopilot system.

Flight Controls Configuration Page

These selections are made in configuration mode using the Flight Controls page.

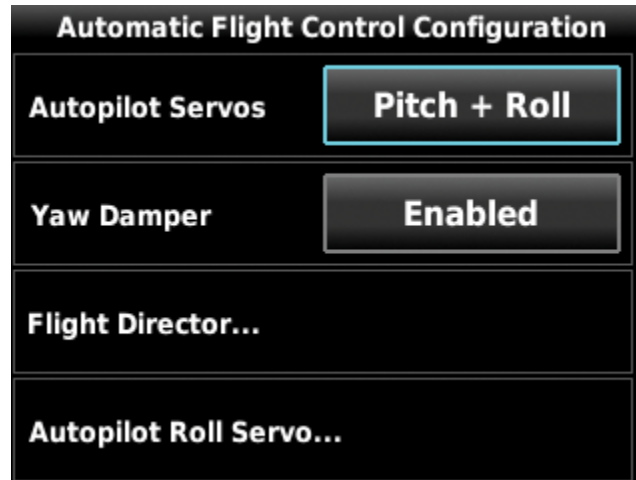

Figure 8-29 Automatic Flight Control Configuration Page

Table 8-6 Flight Control Configuration Settings

Configuration Setting	Description
Trim Low Airspeed Threshold	The GSA 28 servos are capable of airspeed scheduling the aircraft's manual electric trim. The Trim Low Airspeed Threshold setting is the airspeed at which the trim motor will be moved at its fastest setting. This should be the lower of the two airspeeds. The recommended setting for the Trim Low Airspeed Threshold is the airspeed typically used for cruise flight.
Trim High Airspeed Threshold	The GSA 28 servos are capable of airspeed scheduling the aircraft's manual electric trim. The Trim High Airspeed Threshold setting is the airspeed at which the trim motor will be moved at its slowest setting. This should be the higher of the two airspeeds. The recommended setting for the Trim High Airspeed Threshold is the airspeed typically used to fly the normal aircraft landing pattern.

Table 8-6 Flight Control Configuration Settings

Configuration Setting	Description
Control Wheel Steering	<p>The CWS/DISCONNECT discrete input to the GSA 28 servos is connected to a momentary push button which can function either as a dedicated Autopilot Disconnect (AP DISC) button, or as a combined Autopilot Disconnect / Control Wheel Steering (AP/CWS) button.</p> <p>Regardless of configuration, a short press and release of the AP DISC or AP/CWS button will disengage the autopilot if it is engaged.</p> <p>If Control Wheel Steering is enabled, pressing and holding the AP/CWS button places the autopilot into CWS mode. In CWS mode, the servos are temporarily disengaged, allowing hand-flying of the aircraft to a new aircraft attitude while the AP/CWS button is held. When the AP/CWS button is released, the autopilot exits CWS mode and the flight director synchronizes to the current aircraft attitude (if applicable for the current flight director mode).</p> <p>If Control Wheel Steering is disabled, CWS is not supported and the AP button serves as a dedicated AP DISC button only. The AP DISC button will disconnect the autopilot any time it is pressed, regardless of how long it is held.</p>
Engage AP Via CWS Input	<p>If Control Wheel Steering is enabled, the AP/CWS button can optionally be configured to engage the autopilot when pressed and held.</p> <p>If Engage AP Via CWS Input is enabled, the autopilot will automatically engage when the AP/CWS button is pressed and held.</p> <p>If Engage AP Via CWS Input is disabled, pressing the AP/CWS button while the autopilot is not engaged has no effect. In this state, the autopilot can only be engaged using the GMC 305/307 AP button.</p>
AFCS Setup Page	<p>Controls access to the Automatic Flight Control System Setup page in normal mode. Leave this item set to Enabled unless specifically required for the installation.</p>

Roll Servo Configuration Page

The installer needs to make the following roll servo configuration selections when setting up the GSA 28 based autopilot system. All selections are available in configuration mode using the Autopilot Roll Servo Configuration page. Selections available in the normal mode Setup menu are noted with an asterisk in Table 8-7.

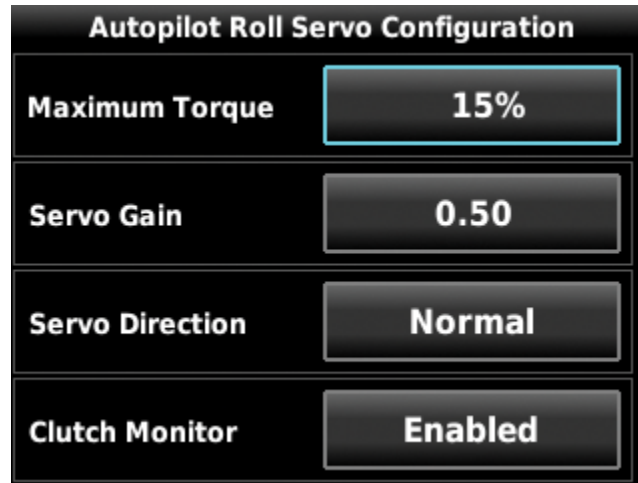

Figure 8-30 Automatic Roll Servo Configuration Page

Table 8-7 Autopilot Roll Servo Configuration Settings

Configuration Setting	Description
Maximum Torque*	The GSA 28 roll servo has a configurable maximum torque setting. This determines how much torque the servo will output before the electronic slip clutch begins to slip. The Maximum Torque setting should be set high enough to not slip during in-flight air loading, but low enough for the pilot to override the autopilot if required. The Maximum Torque setting can be adjusted from 15% to 100% in 5% steps.
Servo Gain*	The GSA 28 roll servo has a configurable servo gain setting. This determines how aggressively the roll servo will move the aileron surfaces. The Servo Gain should be set high enough to properly fly the desired roll, heading, and track, but low enough to avoid being overly aggressive in the aileron movements. The servo gain setting can be adjusted from 0.00 to 10.00 in steps of 0.05.

*Available in normal mode

Table 8-7 Autopilot Roll Servo Configuration Settings

Configuration Setting	Description
Servo Direction	<p>The GSA 28 roll servo has a configurable servo direction.</p> <p>The Servo Direction should be set to Normal if a clockwise movement of the servo arm causes a bank left aileron movement.</p> <p>The Servo Direction should be set to Reverse if a counterclockwise movement of the servo arm causes a bank left aileron movement.</p> <p>After selecting the proper servo direction, the installer should engage the autopilot system in normal mode and verify proper aileron response by using HDG/TRK mode and rotating the track bug to the left and to the right of the current track.</p>
Clutch Monitor	<p>The GSA 28 roll servo has the ability to monitor itself for a stuck clutch situation.</p> <p>If the servo has a large amount of side loading (typically due to a capstan installation), this can occasionally lead to invalid stuck clutch failures.</p> <p>The Clutch Monitor should be enabled for all control arm installations.</p> <p>The Clutch Monitor can be disabled for capstan installations with larger side loads to prevent invalid stuck clutch failures.</p>
Trim Motor Control	<p>The GSA 28 roll servo has the ability to control an auxiliary roll trim motor.</p> <p>The Trim Motor Control should be enabled if the GSA 28 roll servo is connected to an auxiliary trim motor.</p> <p>The Trim Motor Control should be disabled if the GSA 28 roll servo is not connected to an auxiliary trim motor.</p>
Trim Motor Direction	<p>The GSA 28 roll servo has a configurable trim motor direction. Select the Normal or Reversed setting depending on which is required for the proper trim motor movement when using the aircraft trim motor switches on the ground with the autopilot disengaged (servos powered).</p>
Trim Low Airspeed Thresh	<p>This setting specifies the airspeed below which the trim motor is always run at the Fastest Trim Motor Speed specified below.</p>
Trim High Airspeed Thresh	<p>This setting specifies the airspeed above which the trim motor is always run at the Slowest Trim Motor Speed specified below.</p>
Fastest Trim Motor Speed	<p>The GSA 28 roll servo will control the aileron trim on the aircraft.</p> <p>The Fastest Trim Motor Speed is the speed at which the roll servo will run the auxiliary trim motor when at or below the Trim Low Airspeed Thresh airspeed.</p> <p>Expressed as a percentage of the maximum auxiliary trim motor speed. The Fastest Trim Motor Speed can be adjusted from 5% to 100% in 5% steps.</p>
Slowest Trim Motor Speed	<p>The GSA 28 roll servo will control the aileron trim on the aircraft.</p> <p>The Slowest Trim Motor Speed is the speed at which the roll servo will run the auxiliary trim motor when at or above the Trim High Airspeed Thresh airspeed.</p> <p>Expressed as a percentage of the maximum auxiliary trim motor speed. The Slowest Trim Motor Speed can be adjusted from 5% to 100% in 5% steps.</p>

*Available in normal mode

Table 8-7 Autopilot Roll Servo Configuration Settings

Configuration Setting	Description
Slowest Auto Trim Motor Speed (expert configuration)	<p>The GSA 28 roll servo has the ability to drive the auxiliary trim motor at various speeds.</p> <p>The Slowest Auto Trim Motor Speed should be set so the auxiliary trim motor will move as slowly as possible. The slowest possible movement will ensure that there is no noticeable aircraft response when the auxiliary trim motor is run during autotrim.</p> <p>The Slowest Auto Trim Motor Speed can be adjusted from 5% to 100% in 5% steps.</p>
Maximum Trim Run Time	<p>The GSA 28 servos can limit the maximum continuous run time of the trim motor. This can be used to help prevent the potential for a trim runaway situation.</p> <p>The Maximum Trim Run Time Limit is the maximum amount of time the trim servo will be run continuously when a manual electric trim input is detected. If the maximum time is exceeded, the pilot will need to release the Manual Electric Trim (MET) control and then reassert it to continue running trim.</p>
Fine Adjust Amount (expert configuration)	<p>The GSA 28 roll servo is capable of making very small adjustments to fine tune the aileron position. The Fine Adjust Amount is the amount in which these adjustments are made. Use the Fine Adjust Amount and Fine Adjust Time to correct very small oscillations in the aircraft.</p> <p>Fine Adjust Amount is an expert configuration setting, and should generally be not be changed by the installer. The default value is 0.</p>
Fine Adjust Time (expert configuration)	<p>The GSA 28 roll servo is capable of making very small adjustments to fine tune the aileron position. The Fine Adjust Time is the rate at which these adjustments are made. Use the Fine Adjust Amount and Fine Adjust Time to correct very small oscillations in the aircraft.</p> <p>Fine Adjust Time is an expert configuration setting, and should generally be not be changed by the installer. The default value is 0.20.</p>

*Available in normal mode

Pitch Servo Configuration Page

The installer needs to make the following pitch servo configuration selections when setting up the GSA 28 based autopilot system. All selections are available in configuration mode using the Autopilot Pitch Servo page. Selections available in the normal mode Setup menu are noted with an asterisk in Table 8-8.



Figure 8-31 Automatic Pitch Servo Configuration Page

Table 8-8 Autopilot Pitch Servo Configuration Settings

Configuration Setting	Description
Maximum Torque*	<p>The GSA 28 pitch servo has a configurable maximum torque setting. This determines how much torque the servo will output before the electronic slip clutch begins to slip.</p> <p>The Maximum Torque setting should be set high enough to not slip during in-flight air loading, but low enough for the pilot to override the autopilot if required.</p> <p>The Maximum Torque setting can be adjusted from 15% to 100% in 5% steps.</p>
Servo Gain*	<p>The GSA 28 pitch servo has a configurable servo gain setting. This determines how aggressively the pitch servo will move the elevator surfaces.</p> <p>The Servo Gain should be set high enough to properly fly the desired pitch, vertical speed, and altitude, but low enough to avoid being overly aggressive in the elevator movements.</p> <p>The servo gain setting can be adjusted from 0.00 to 10.00 in steps of 0.05.</p>
Servo Direction	<p>The GSA 28 pitch servo has a configurable servo direction.</p> <p>The Servo Direction should be set to Normal if a clockwise movement of the servo arm causes a nose down elevator movement.</p> <p>The Servo Direction should be set to Reverse if a counterclockwise movement of the servo arm causes a nose down elevator movement.</p> <p>After selecting the proper servo direction, the installer should engage the autopilot system in normal mode and verify proper elevator response by rotating the pitch reference up and down from the current pitch.</p>

*Available in normal mode

Table 8-8 Autopilot Pitch Servo Configuration Settings

Configuration Setting	Description
Clutch Monitor	<p>The GSA 28 pitch servo has the ability to monitor itself for a stuck clutch situation.</p> <p>If the servo has a large amount of side loading (typically due to a capstan installation), this can occasionally lead to invalid stuck clutch failures. The Clutch Monitor should be enabled for all control arm installations.</p> <p>The Clutch Monitor can be disabled for capstan installations with larger side loads to prevent invalid stuck clutch failures.</p>
Trim Motor Control	<p>The GSA 28 pitch servo has the ability to control an auxiliary pitch trim motor. The Trim Motor Control should be enabled if the GSA 28 pitch servo is connected to an elevator trim motor.</p> <p>The Trim Motor Control should be disabled if the GSA 28 pitch servo is not connected to an auxiliary trim motor.</p>
Trim Motor Direction	<p>The GSA 28 pitch servo has a configurable trim motor direction. Select the Normal or Reversed setting depending on which is required for the proper trim motor movement when using the aircraft trim motor switches on the ground with the autopilot disengaged (servos powered).</p>
Fastest Trim Motor Speed	<p>The GSA 28 pitch servo will control the elevator trim on the aircraft. The Fastest Trim Motor Speed is the speed at which the pitch servo will run the auxiliary trim motor when at or below the corresponding airspeed. Expressed as a percentage of the maximum auxiliary trim motor speed. The Fastest Trim Motor Speed can be adjusted from 5% to 100% in 5% steps.</p>
Slowest Trim Motor Speed	<p>The GSA 28 pitch servo will control the elevator trim on the aircraft. The Slowest Trim Motor Speed is the speed at which the pitch servo will run the auxiliary trim motor when at or above the corresponding airspeed. Expressed as a percentage of the maximum auxiliary trim motor speed. The Slowest Trim Motor Speed can be adjusted from 5% to 100% in 5% steps.</p>
Slowest Auto Trim Motor Speed (expert configuration)	<p>The GSA 28 pitch servo has the ability to drive the auxiliary trim motor at various speeds. The Slowest Auto Trim Motor Speed should be set so the auxiliary trim motor will move as slowly as possible. The slowest possible movement will ensure that there is no noticeable aircraft response when the auxiliary trim motor is run during autotrim.</p> <p>The Slowest Auto Trim Motor Speed can be adjusted from 5% to 100% in 5% steps.</p>
Maximum Trim Run Time	<p>The GSA 28 servos can limit the maximum continuous run time of the trim motor. This can be used to help prevent the potential for a trim runaway situation. The Maximum Trim Run Time Limit is the maximum amount of time the trim servo will be run continuously when a manual electric trim input is detected. If the maximum time is exceeded, the pilot will need to release the Manual Electric Trim (MET) control and then reassert it to continue running trim.</p>

*Available in normal mode

Table 8-8 Autopilot Pitch Servo Configuration Settings

Configuration Setting	Description
Fine Adjust Amount (expert configuration)	<p>The GSA 28 pitch servo is capable of making very small adjustments to fine tune the elevator position. The Fine Adjust Amount is the amount in which these adjustments are made. Use the Fine Adjust Amount and Fine Adjust Time to correct very small oscillations in the aircraft.</p> <p>Fine Adjust Amount is an expert configuration setting, and should generally be not be changed by the installer. The default value is 0.</p>
Fine Adjust Time (expert configuration)	<p>The GSA 28 pitch servo is capable of making very small adjustments to fine tune the elevator position. The Fine Adjust Time is the rate at which these adjustments are made. Use the Fine Adjust Amount and Fine Adjust Time to correct very small oscillations in the aircraft.</p> <p>Fine Adjust Time is an expert configuration setting, and should generally be not be changed by the installer. The default value is 0.20.</p>
Minimum Airspeed Limit*	<p>The GSA 28 pitch servo has a configurable minimum airspeed limit. This determines the lowest airspeed at which the pitch servo will allow the aircraft to fly. If the airspeed drops below this limit, the pitch servo will lower the nose of the aircraft to keep the airspeed at or above the Minimum Airspeed Limit.</p> <p>The Minimum Airspeed Limit should be set above the aircraft stall speed with some margin.</p>
Maximum Airspeed Limit*	<p>The GSA 28 pitch servo has a configurable maximum airspeed limit. This determines the fastest airspeed at which the pitch servo will allow the aircraft to fly. If the airspeed rises above this limit, the pitch servo will raise the nose of the aircraft to keep the airspeed at or below the Maximum Airspeed Limit.</p> <p>The Maximum Airspeed Limit should be set below the aircraft maximum speed with some margin.</p>
Vertical Speed Gain*	<p>The GSA 28 pitch servo is capable of holding the aircraft at a desired vertical speed.</p> <p>The Vertical Speed Gain should be increased if the aircraft struggles to hold the desired vertical speed target when the flight director is in VS, ALT, or LVL modes.</p> <p>The Vertical Speed Gain should be decreased if the aircraft is overly aggressive when trying to hold the desired vertical speed.</p>
Vertical Acceleration Gain*	<p>The GSA 28 pitch servo is capable of holding the aircraft at a desired vertical speed.</p> <p>The Vertical Acceleration Gain should be increased if the aircraft is overshooting the desired vertical speed target when closing on the bug when the flight director is in VS mode.</p> <p>The Vertical Acceleration Gain should be decreased if the aircraft appears to back off from the desired vertical speed target when closing on the bug.</p>

*Available in normal mode

Table 8-8 Autopilot Pitch Servo Configuration Settings

Configuration Setting	Description
Airspeed Gain*	<p>The GSA 28 pitch servo is capable of holding the aircraft at a desired airspeed.</p> <p>The Airspeed Gain should be increased if the aircraft is lazy and struggles to hold the desired airspeed target when the flight director is in IAS mode.</p> <p>The Airspeed Gain should be decreased if the aircraft is overly aggressive when trying to hold the desired airspeed target.</p>
Airspeed Acceleration Gain (expert configuration)	<p>The GSA 28 pitch servo is capable of holding the aircraft at a desired airspeed.</p> <p>The Airspeed Acceleration Gain should be increased if the aircraft is overshooting the desired airspeed target when closing on the bug when the flight director is in IAS mode.</p> <p>The Airspeed Acceleration Gain should be increased if the aircraft appears to back off from the desired airspeed target when closing on the bug.</p>
Airspeed Tracking Gain (expert configuration)	<p>The GSA 28 pitch servo is capable of holding the aircraft at a desired airspeed.</p> <p>The Airspeed Tracking Gain should be increased if the aircraft is overly sluggish while tracking airspeed when the airspeed error is less than 5 knots.</p> <p>The Airspeed Tracking Gain should be decreased if the aircraft is overly aggressive while tracking airspeed when the airspeed error is less than 5 knots.</p>

*Available in normal mode

Yaw Damper Configuration Page

The installer needs to make the following yaw damper configuration selections when setting up the GSA 28 based autopilot system. All selections are available in configuration mode using the Yaw Damper page. Selections available in the normal mode Setup menu are noted with an asterisk in Table 8-9.



Figure 8-32 Yaw Damper Configuration Page

Table 8-9 Yaw Damper Configuration Settings

Configuration Setting	Description
Maximum Torque*	<p>The GSA 28 yaw damper has a configurable maximum torque setting. This determines how much torque the servo will output before the electronic slip clutch begins to slip.</p> <p>The Maximum Torque setting should be set high enough to not slip during in-flight air loading, but low enough for the pilot to override the autopilot if required. The Maximum Torque setting can be adjusted from 15% to 100% in 5% steps.</p>
Servo Gain*	<p>The GSA 28 yaw damper has a configurable servo gain setting. This determines how aggressively the yaw servo will move the rudder surface.</p> <p>The Servo Gain should be set high enough to dampen the yaw rates, but low enough to avoid being overly aggressive in the rudder movements. The servo gain setting can be adjusted from 0.00 to 10.00 in steps of 0.05.</p>
Servo Direction	<p>The GSA 28 yaw damper has a configurable servo direction.</p> <p>The Servo Direction should be set to Normal if a clockwise movement of the servo arm causes a nose left rudder movement.</p> <p>The Servo Direction should be set to Reverse if a counterclockwise movement of the servo arm causes a nose left rudder movement.</p> <p>After selecting the proper servo direction, the installer should engage the yaw damper in normal mode and verify proper rudder response by the tail of the aircraft back and forth.</p>

*Available in normal mode

Table 8-9 Yaw Damper Configuration Settings

Configuration Setting	Description
Clutch Monitor	<p>The GSA 28 yaw damper has the ability to monitor itself for a stuck clutch situation.</p> <p>If the servo has a large amount of side loading (typically due to a capstan installation), this can occasionally lead to invalid stuck clutch failures. The Clutch Monitor should be enabled for all control arm installations.</p> <p>The Clutch Monitor can be disabled for capstan installations with larger side loads to prevent invalid stuck clutch failures.</p>
Trim Motor Control	<p>The GSA 28 yaw damper has the ability to control an auxiliary rudder trim motor. The Trim Motor Control should be enabled if the GSA 28 yaw damper is connected to an elevator trim motor.</p> <p>The Trim Motor Control should be disabled if the GSA 28 yaw damper is not connected to an auxiliary trim motor.</p>
Trim Motor Direction	<p>The GSA 28 yaw servo has a configurable trim motor direction. Select the Normal or Reversed setting depending on which is required for the proper trim motor movement when using the aircraft trim motor switches on the ground with the autopilot disengaged (servos powered).</p>
Fastest Trim Motor Speed	<p>The GSA 28 yaw servo will control the rudder trim on the aircraft. The Fastest Trim Motor Speed is the speed at which the yaw damper will run the auxiliary trim motor when at or below the corresponding airspeed. Expressed as a percentage of the maximum auxiliary trim motor speed. The Fastest Trim Motor Speed can be adjusted from 5% to 100% in 5% steps.</p>
Slowest Trim Motor Speed	<p>The GSA 28 yaw servo will control the rudder trim on the aircraft. The Slowest Trim Motor Speed is the speed at which the yaw damper will run the auxiliary trim motor when at or above the corresponding airspeed. Expressed as a percentage of the maximum auxiliary trim motor speed. The Slowest Trim Motor Speed can be adjusted from 5% to 100% in 5% steps.</p>
Slowest Auto Trim Motor Speed (expert configuration)	<p>The GSA 28 yaw damper has the ability to drive the auxiliary rudder trim motor at various speeds. The Slowest Auto Trim Motor Speed should be set so the auxiliary trim motor will move as slowly as possible. The slowest possible movement will ensure that there is no noticeable aircraft response when the auxiliary trim motor is run during autotrim.</p> <p>The Slowest Auto Trim Motor Speed can be adjusted from 5% to 100% in 5% steps.</p>
Maximum Trim Run Time	<p>The GSA 28 servos can limit the maximum continuous run time of the trim motor. This can be used to help prevent the potential for a trim runaway situation. The Maximum Trim Run Time Limit is the maximum amount of time the trim servo will be run continuously when a manual electric trim input is detected. If the maximum time is exceeded, the pilot will need to release the Manual Electric Trim (MET) control and then reassert it to continue running trim.</p>

*Available in normal mode

Table 8-9 Yaw Damper Configuration Settings

Configuration Setting	Description
Ball Centering Gain (expert configuration)	<p>The GSA 28 yaw damper is capable of zeroing the aircraft's lateral acceleration or centering the ball as well as dampening aircraft yaw rates.</p> <p>Ball Centering Gain is an expert configuration setting and should only be changed by the installer if the yaw damper is not properly zeroing the aircraft's lateral acceleration.</p> <p>Increasing the Ball Centering Gain will cause the yaw damper to more aggressively respond to non-zero lateral acceleration. Decreasing the Ball Centering Gain will cause the yaw damper to respond less aggressively to non-zero lateral acceleration.</p>
Yaw Rate Filter Constant (expert configuration)	<p>The GSA 28 yaw damper is capable of dampening yaw body rates to keep the aircraft from shaking its tail. The Yaw Rate Filter Constant is used to filter the aircraft yaw body rate.</p> <p>Yaw Rate Filter Constant is an expert configuration setting, and should generally be not be changed by the installer. The default value is 0.08.</p>
Yaw Acceleration Filter Constant (expert configuration)	<p>The GSA 28 yaw damper is capable of zeroing the lateral acceleration of the aircraft. The Yaw Acceleration Filter Constant is used to filter the aircraft lateral acceleration.</p> <p>Yaw Acceleration Filter Constant is an expert configuration setting, and should generally be not be changed by the installer. The default value is 0.16.</p>

*Available in normal mode

8.4.8 Flight Director Configuration Page

This page allows for configuration of certain options for the flight director. It will only appear in installations that include an autopilot.

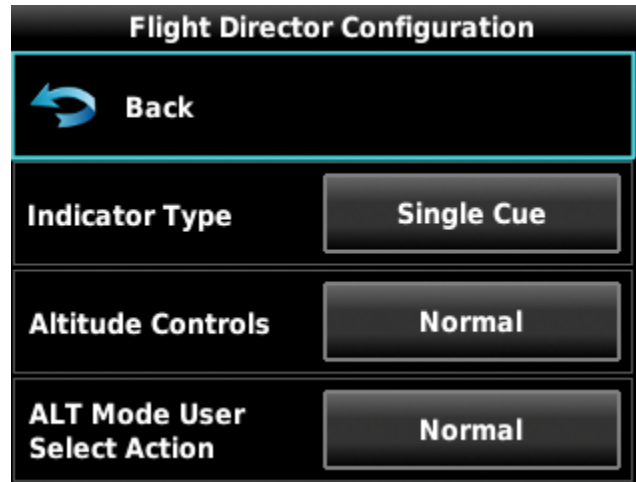

Figure 8-33 Flight Director Configuration Page

Table 8-10 Flight Director Configuration Settings

Configuration Setting	Description
Indicator Type	Controls whether the flight director command indicator on the PFD uses a single-cue or dual-cue presentation.
Altitude Controls	Select Normal (default) or Simplified. Selecting Simplified results in a simpler set of behaviors for altitude hold mode. When Altitude Controls is set to Normal, ALT Mode User Select Action and ALT Mode User Up/Down Action will appear. When Altitude Controls is set to Simplified, the ALT Mode User Select Action and ALT Mode User Up/Down Action settings do not appear. In their places, selections for the default climb and descent vertical speeds are displayed.
ALT Mode User Select Action	Select Normal or Sync Selected Altitude. This setting controls the actions that occur when the user selects altitude hold mode by pressing the ALT key on the GMC 305/307. When set to Sync Selected Altitude, the selected altitude (altitude bug) will be automatically set to the current aircraft altitude when the user selects altitude hold mode manually by pressing the ALT key on the GMC 305/307.
ALT Mode User Up/Down Action	Select Normal or Select VS Mode. This setting controls the actions that occur when the flight director is in altitude hold mode and the user moves the pitch wheel on the GMC 305/307. When set to Select VS Mode, moving the pitch wheel on the GMC 305/307 results in a change to VS mode for a climb or descent to a new altitude.
Maximum Bank Angle	Used to limit the maximum roll attitude commanded by the flight director for aircraft that have unusual attitude limitations. This setting should not be adjusted from the default of 30° except for very high performance aircraft that have bank angle limitations at high speeds.

8.4.9 Electronic Stability Protection Configuration Page

This page allows for configuration of certain options for the ESP (Electronic Stability Protection) function. It will only appear in installations that include an autopilot with Garmin servos. ESP is an optionally enabled feature that is intended to assist the pilot in maintaining the aircraft in a stable flight condition. This feature will only function when the aircraft is above 200 feet AGL and the autopilot is not engaged.

ESP engages when the aircraft exceeds one or more conditions (pitch, roll, airspeed) beyond the normal flight parameters. Enhanced stability for each condition provides a force to the appropriate control surface to return the aircraft to the normal flight envelope. This is perceived by the pilot as resistance to control movement in the undesired direction when the aircraft approaches a steep attitude or high airspeed. As the aircraft deviates further from the normal attitude and/or airspeed, the force increases (up to an established maximum) to encourage control movement in the direction necessary to return to the normal attitude and/or airspeed range.

See the G5 Pilot's Guide (190-02072-00) for details of ESP operation.

Table 8-11 ESP Configuration Settings

Configuration Setting	Description
Roll Attitude Protection	Select Enabled or Disabled (all other fields remain blank when Disabled).
Roll Limit	Enter desired Bank Limit of aircraft (range 45° to 60°, this limit will appear as Guardrails on the PFD).
Pitch Attitude Protection	Select Enabled or Disabled.
Pitch Up Limit	Enter desired Pitch Limit of aircraft. Allowable range of +10° to +25° (default setting +20°)
Pitch Down Limit	Enter desired Pitch Limit of aircraft. Allowable range of -10° to -25° (default setting -15°)
Airspeed Protection	Select Enabled or Disabled. Note that the minimum airspeed setting should be set to a value lower than the minimum airspeed that is anticipated during approach while above 200 ft AGL.
Minimum Airspeed Limit	Enter minimum airspeed of aircraft, minimum setting is 50 kt
Maximum Airspeed Limit	Enter maximum airspeed of aircraft, maximum setting is 999 kt
Default ESP Powerup State	Select Enabled or Disabled. Setting determines whether the ESP is functioning upon power up. If disabled, ESP can still be enabled in normal operating mode.
Auto Engage LVL Mode	Select Enabled or Disabled. When enabled, the autopilot will engage with the flight director in Level Mode to bring the aircraft into level flight if ESP has been engaged for more than 15 seconds of a 30 second time period.

8.4.10 Backlight Configuration Page

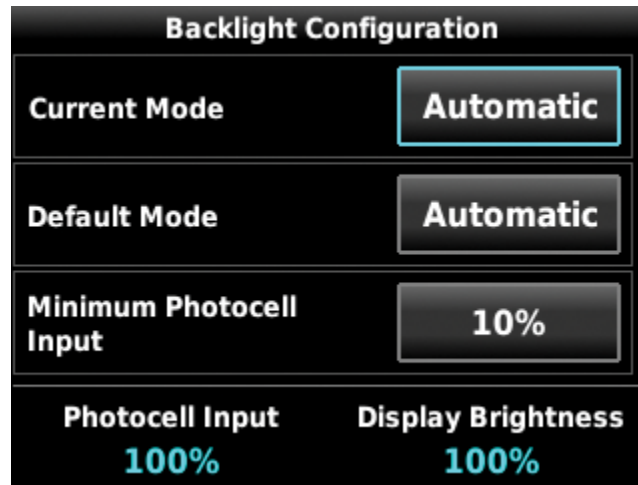

Figure 8-34 Backlight Configuration Page

Table 8-12 Backlight Configuration Settings

Configuration Setting	Description
Current Mode	Used to set the backlight mode to automatic or manual. This setting is also available at any time by pressing the power button. Automatic mode sets the backlight intensity (display brightness) based on the photocell (ambient light sensor) input on the G5. Manual mode allows for setting the backlight intensity by changing the Backlight percentage directly. Manual brightness control is available at any time by pressing the power button.
Default Mode	Used to set the backlight mode that will be active each time the unit is powered on.
Minimum Photocell Input	Sets the photocell reading that will result in the minimum display brightness in automatic mode. The default is 10%.
Minimum Display Brightness	Sets the minimum display brightness setting that will occur in automatic mode. The default value is 20%.
Maximum Photocell Input	Sets the photocell reading that will result in the maximum display brightness in automatic mode. The default is 70%.
Maximum Display Brightness	Sets the maximum display brightness setting that will occur in automatic mode. The default value is 100%.
Filter Time Constant	Adjusts the speed (in seconds) that the brightness level responds to changes in the photocell input.
Photocell Input	Displays the current input on the unit's light sensor (0%-100%).
Display/Manual Brightness	Displays the current backlight level (0%-100%). Naming convention depends on the current backlight mode selected.

8.4.11 Display Configuration Page

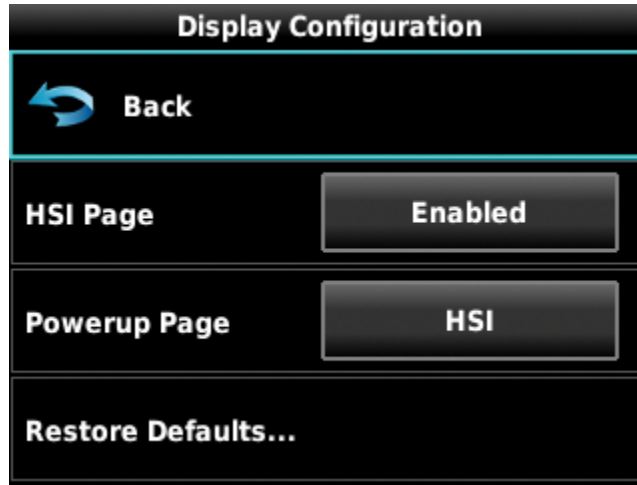

Figure 8-35 Display Configuration Page

Table 8-13 Display Configuration Settings

Configuration Setting	Description
HSI Page	Enables and disables access to the HSI page in normal mode.
Powerup Page	Sets the default page (PFD or HSI) displayed at unit power on. The HSI page cannot be configured as the default powerup page on the #1 G5 in a G3X system.

8.4.12 Battery Configuration Page

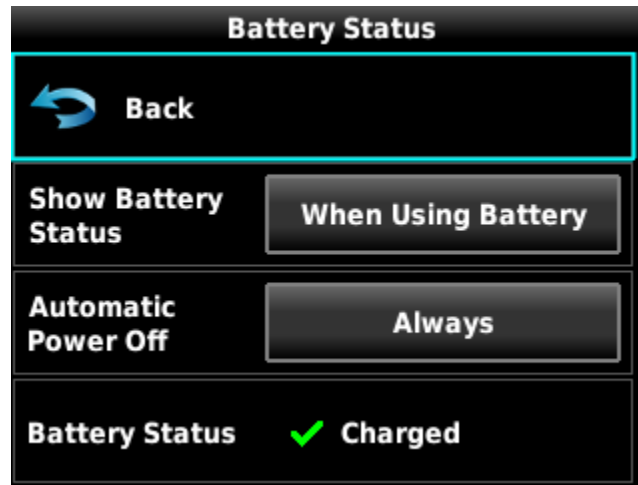

Figure 8-36 Battery Status Page

In addition to the configuration settings listed in Table 8-14, this page also displays the following battery information:

- Battery Status
- Charge Level
- Temperature
- Voltage
- Charge Cycles
- Lifetime Remaining

Table 8-14 Battery Configuration Settings

Configuration Setting	Description
Show Battery Status	Select When Using Battery to only display the status of the G5 backup battery when the unit is operating from the battery (i.e. aircraft power has been removed). Select Always to constantly display the status of the G5 backup battery. The battery status will be displayed regardless of the status of aircraft power or whether a battery is connected to the G5.
Automatic Power Off	Select Always to initiate the external power lost countdown timer anytime the G5 loses power. Select On Ground Only to initiate the external power lost countdown timer only when the G5 loses power and the airspeed is less than 20 kts.

8.4.13 GPS Configuration Page

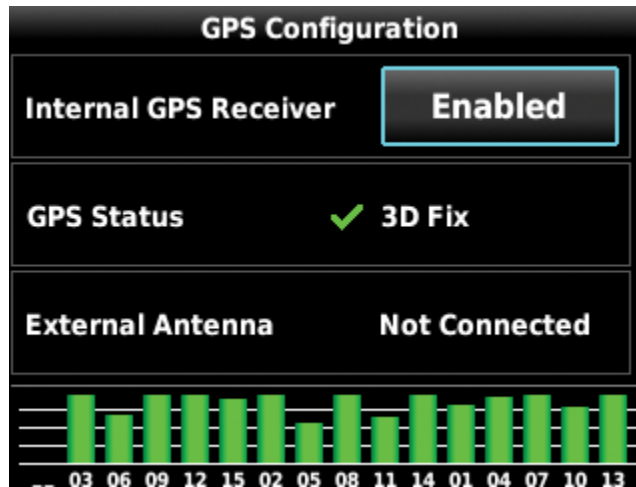

Figure 8-37 GPS Configuration Page

Table 8-15 GPS Configuration Settings

Configuration Setting	Description
Internal GPS Receiver	Enables and disables the internal GPS receiver on the G5. The internal receiver is typically disabled in installations where the mounting location leads to poor GPS reception and an external GPS antenna is not installed. When the internal GPS receiver is disabled, the G5 is still able to receive GPS data from an external navigation source such as other Garmin LRUs (e.g. GDU37X/4XX, GPS 20A, or secondary G5).
GPS Status	Displays the status of the internal GPS receiver on the G5. A green check mark indicates a valid GPS fix has been acquired.
External Antenna	Displays the connection status of the external GPS antenna (if equipped).
GPS Data Fields	Shows and hides the GPS data from the PFD. When hidden, GPS data is still used for attitude validation (when available).

8.4.13.1 Testing the GPS Receiver for COM Interference

This test must be conducted outside, as the use of a GPS repeater inside a hangar may result in a failed test.

1. Ensure a valid GPS position fix is obtained by monitoring the GPS status. The following status indications are valid fixes for this test.
 - 3D Fix
 - 3D Differential
2. Select 121.150 MHz on the COM transceiver.
3. Transmit for a period of 30 seconds while monitoring the GPS status.
4. During the transmit period, verify that the GPS status does not lose a valid GPS position fix.
5. Repeat steps 2 through 4 for the following frequencies:
 - 121.175 MHz
 - 121.200 MHz
 - 131.250 MHz
 - 131.275 MHz
 - 131.300 MHz
6. Repeat steps 2 through 5 for all other installed COM transceivers (if applicable).
7. If an installed COM supports 8.33 MHz channel spacing, increase the transmit period to 35 seconds and repeat steps 3 through 5 for the following frequencies:
 - 121.185 MHz
 - 121.190 MHz
 - 130.285 MHz
 - 131.290 MHz
8. Repeat step 7 for all other installed COM transceivers supporting 8.33 MHz channel spacing (if applicable).



NOTE

The signal strength bars at the bottom of the GPS Configuration page are a real-time representation of GPS signal strength, which may be useful for troubleshooting a failed COM interference test.

8.4.13.2 Navigation Configuration Page

This page is only available if a navigation data source is configured via RS-232 or ARINC 429.

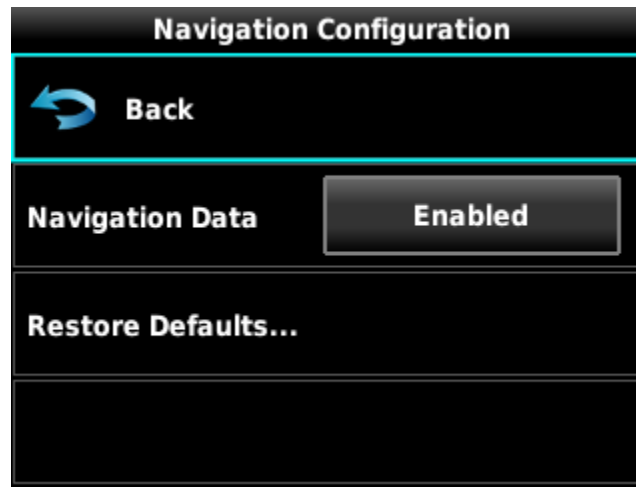

Figure 8-38 Navigation Configuration Page

Table 8-16 Navigation Configuration Settings

Configuration Setting	Description
Navigation Data	<p>For a standalone unit (not part of a G3X system), this setting enables and disables the display of navigation data in normal mode. Navigation data cannot be hidden when autopilot servos are configured.</p> <p>For a backup unit (part of a G3X system), this setting controls how the G5 selects the navigation data source to display when communicating with a G3X display.</p> <p>Select Auto to display navigation data from the #1 ARINC 429 source when the G3X display is showing the same navigation data. If the G3X display's navigation source is changed to internal GPS or a navigation source not supported by the G5, then no navigation data will be displayed on the G5. This prevents the G5 and G3X display from showing different sources of navigation data simultaneously.</p> <p>Select Always Display to always show the navigation data the G5 is receiving over RS-232 and/or the #1 ARINC 429 source, even if that data is different that what is shown on the G3X display.</p> <p>Regardless of the Navigation Data setting, when no G3X displays are present, the G5 will always display the navigation data it is receiving over RS-232 and/or the #1 ARINC 429 source, or when dual navigation sources are installed, the G5 will display the navigation data from the selected source.</p>

8.4.13.3 Units Configuration Page

This page allows for configuration of the displayed units. The units for each measurement can be selected using the knob on the G5.

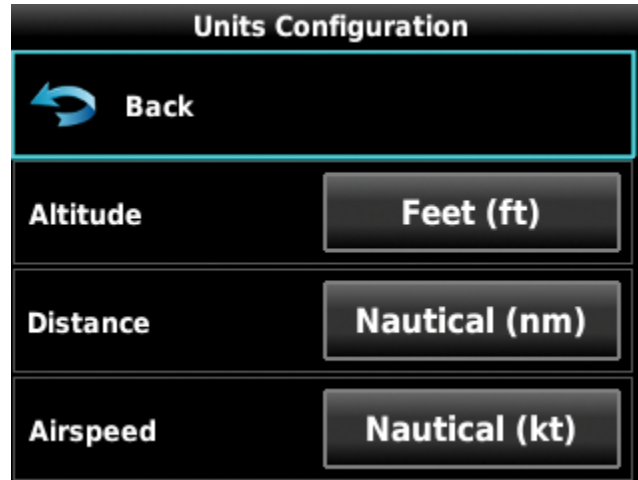

Figure 8-39 Units Configuration Page

The Units Configuration page also allows for the selection of Normal or Alternate Data Field Units Display. Normal corresponds to unit labeling that is consistent with the G3X system - color-matched to the value and displayed to the right of the value.



Figure 8-40 Normal Data Field Units

Selecting Alternate will slightly change the display of the data field units. On the PFD page, the unit symbols will be removed from the groundspeed, selected altitude, and barometric setting fields.



Figure 8-41 Alternate Data Field Units on PFD Page

If the units for airspeed and groundspeed are not the same, the title for the groundspeed field will be moved above the value and updated to include the unit (color-matched to the title).



Figure 8-42 Non-Matching Airspeed and Groundspeed Units

On the HSI page, all data field titles will be moved above the value and updated to include the unit (color-matched to the title).



Figure 8-43 Alternate Data Field Units on HSI Page

8.4.13.4 RS-232 Configuration Page

This page allows for configuration of the serial communication port on the G5. Both the input and output serial port formats can be configured independently. Some input/output formats will also allow for a configurable baud rate.

A green checkmark will appear next to the input format selection when the RS-232 port is receiving valid data. A green checkmark will not appear if data has not yet been received by the unit. A red "X" is displayed if no data has been received after an initial time-out period, or if data has been received and is then interrupted.

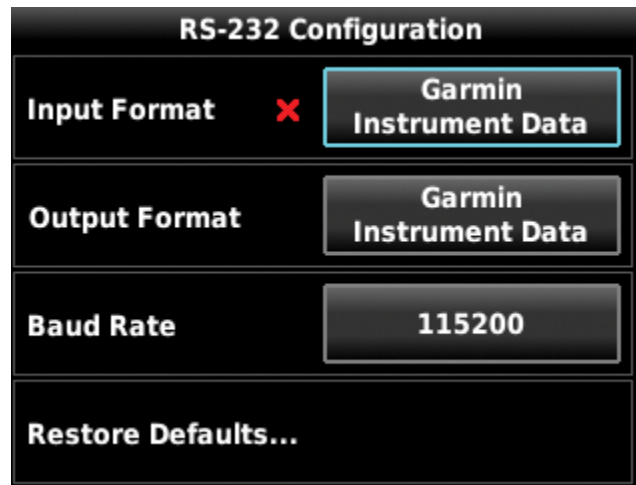

Figure 8-44 RS-232 Configuration Page

Table 8-17 RS-232 Input Configuration Settings

Configuration Setting	Description
Aviation	The proprietary format used for input of navigation data to the G5 at a fixed baud rate of 9600 from an FAA certified Garmin panel mount unit. If the external GPS navigator supports both the Aviation and MapMX formats, the MapMX format is recommended.
Garmin Instrument Data	Used for connecting to compatible Garmin LRUs (e.g. GMC 305/307).
Garmin VHF Nav Radio	Receives lateral and vertical NAV deviation signals as an input format. Transmits GPS data and selected course to a GNC 255 or SL 30 NAV radio.
MapMX	The preferred input format when interfacing with an external navigator. This format is only available from Garmin units equipped with a WAAS GPS receiver. MapMX Format 1 and MapMX Format 2 are also acceptable formats for the navigator serial port configuration when using MapMX format on the G5. In a dual GNS/GTN installation, connect the MapMX output from unit #1 to the G5.
NMEA	Supports the input and output of standard NMEA 0183 version 3.01 data at a configurable baud rate of either 4800 or 9600. The G5 outputs GPS data via NMEA sentences. This input format is used when interfacing a portable GPS navigation unit like a Garmin Aera 660.

Table 8-18 RS-232 Output Configuration Settings

Configuration Setting	Description
Altitude Encoder	Outputs altitude encoder data to a compatible transponder. Both Icarus and Shadin-format messages are output when using this setting.
Garmin Instrument Data	Used for connecting to compatible Garmin LRUs (e.g. GMC 305/307).
Garmin VHF Nav Radio	Receives lateral and vertical NAV deviation signals as an input format. Transmits GPS data and selected course to a GNC 255 or SL 30 NAV radio.
NMEA	Supports the input and output of standard NMEA 0183 version 3.01 data at a configurable baud rate of either 4800 or 9600. The G5 outputs GPS data via NMEA sentences.
Text	Outputs attitude, air data, and GPS position/velocity text data as described in Section 11.4

8.4.13.5 ARINC 429 Configuration Page

This page allows for configuration of the 2 ARINC 429 output and 4 ARINC 429 input ports on the G5.

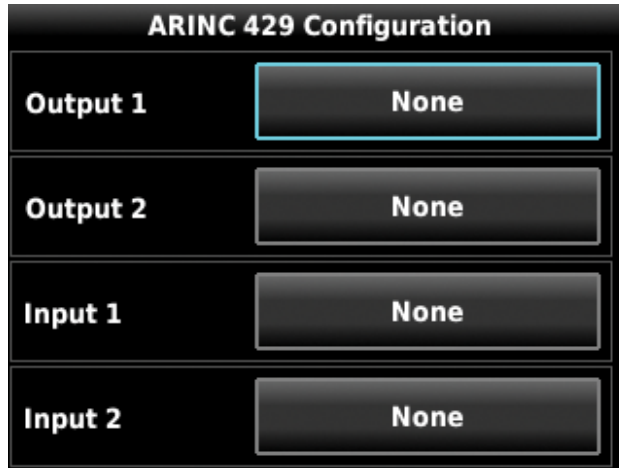

Figure 8-45 ARINC 429 Configuration Page

Table 8-19 ARINC 429 Outputs

Configuration Setting	Description
EFIS/Airdata (SDI 1, SDI 2, common)	Outputs EFIS and air data labels to a GNS 4XX/5XX series unit. The transmitted labels are as follows: 100P Selected GPS Course 101 Selected Heading 102 Selected Altitude 110 Selected VLOC Course 203 Pressure Altitude 204 Baro Corrected Altitude 206 Indicated Airspeed 212 Vertical Speed 235 Baro Setting (BCD) 320 Magnetic Heading 371G Manufacturer ID 377 Equipment ID
EFIS Course (SDI 1, SDI 2, Common)	100P Selected GPS Course 371G Manufacturer ID 377 Equipment ID

Table 8-20 ARINC 429 Inputs

Configuration Setting	Description
Garmin GPS (SDI 1, SDI 2, Common)	Receives GPS labels from a GNS 4XX/5XX or GTN 6XX/7XX series unit.
Garmin VOR/ILS (SDI 1, SDI 2, Common)	Receives VOR/ILS labels from a GNS 4XX/5XX, GTN 6XX/7XX, or GNC 255 unit.

9 TROUBLESHOOTING

In this manual, the term ‘Red-X’ refers to a red “X” that appears on different areas of the display to indicate the failure of that particular function.

For additional assistance, contact your local avionics dealer. If further help is needed, contact Garmin Aviation Product Support at US Toll Free Number 1-888-606-5482, or US 1-913-397-8200.



NOTE

The information in this section is for troubleshooting use only and does not supersede any approved maintenance or other installation instructions.

9.1 General Troubleshooting

1. Review the airframe logbook to verify if any G5 or other avionics or electrical maintenance had been performed recently that may have contributed to the failure.
2. Check for loose wire terminals on the circuit breaker connections on the power wire(s) causing intermittent power connections. Also, check for intermittent circuit breakers.
3. Have ground power put on the aircraft.
4. Turn on the G5 and record the system software version displayed on the start up page.
5. After the system is initialized, note any Red-X’s on the display or anywhere in the configuration mode menus.

If the failure cannot be verified, proceed to the following physical inspection.

1. Power cycle the G5 or any affected LRU by removing aircraft power, waiting 30 seconds, then reapplying power.
2. Check that all connectors are fully seated, and that the jack screw connectors are fully tightened on both sides of all connectors.
3. Check for a loose wire harness that is able to move around during flight. This condition may cause the wire to pull on or vibrate the connector, making intermittent connections.
4. Ensure that the G5 or any affected LRU is mounted securely. Use the appropriate tool to check the tightness of all mounting hardware.
5. Look for any heavy objects that may not be fastened tight to the aircraft structure that could be inducing vibration in the G5’s attitude sensors.
6. Look for evidence of water or fluid contamination in the area around the G5 or any affected LRU.
7. Unplug the connector on the G5 or any affected LRU and check for bent pins.
8. Inspect the wire harness clamp on the rear of all connectors to verify that it is not too tight and smashing/shorting the wires. If the wire clamp is installed upside down, it has sharp edges that can cut into the wires. Verify the presence of protective wire wrap between the wires and the clamp.

If the condition is not resolved by following the preceding instructions, contact Garmin Product Support for additional assistance. A Garmin Field Service Engineer may ask the technician to email any fault or data logs back to Garmin to help determine if the condition is caused by a G5, a different LRU, or a source elsewhere in the aircraft installation.

9.2 SD Card Slot

A stuck or sticking microSD™ card issue can sometimes be caused by the card thickness variability (especially if there is more than one label on the card). This is usually caused by the card sticking in the overlay opening, not by the card sticking to the socket inside the unit. Try another card (without a label, if possible) to confirm the problem before returning. If the second card sticks, the microSD™ socket board inside the unit may be misaligned with the overlay and the G5 will require repair. If the thickness of the card was the cause, see if more than one label was on the card. If the labels weren't the cause, determine what brand of microSD™ card was being used (Garmin recommends using SanDisk® brand cards).

9.3 Unit Communication Error

Communication errors can occur in systems with two G5s due to software versions and unit ID strapping. Multiple G5s connected together should have the same software version installed. Differing versions will be annunciated with a message in normal mode (e.g. "Software version mismatch") and a Red-X in configuration mode. More than one G5 strapped as the same unit (i.e. both unit 1 or both unit 2) will be annunciated with a message (e.g. "Communication error" or "Network address conflict") in normal mode and a Red-X in configuration mode.

9.4 Air Data Troubleshooting

Under normal operating conditions, the G5 provides the following air data information:

- Indicated Airspeed (IAS)
- Barometric Altitude
- Vertical Speed



NOTE

IAS information can only be displayed at speeds greater than 20 knots.

If the airspeed and/or altitude is failed and shows a Red-X condition:

1. Inspect the pitot/static plumbing integrity.
2. Inspect the pitot/static ports and all associated equipment.
3. If the problem persists, replace the G5 with a known good unit.

9.5 Attitude Failure Troubleshooting

To assist with troubleshooting an attitude or track failure, gather answers to the following questions, being as specific as possible. This information may be helpful to the installer/pilot, the avionics dealer, or to Garmin Aviation Product Support in troubleshooting the failure.

1. What was the nature of the failure? Was it a Red-X of only heading, only GPS track, only pitch/roll, or a combination?
2. If there was a Red-X of pitch or roll information, did the unit display an alignment message (which is indicative of a reset), or a failure message (which is indicative of an invalidated output)?
3. What was the aircraft doing in the two minutes that preceded the failure (taxing on the ground, flying straight-and-level flight, turning, climbing, etc.)? If the problem occurred on the ground, was it within 100 feet of a hanger using GPS repeaters?
4. How long did the failure last? Was it brief or sustained? Was it repetitive in nature? If it was repetitive, about how many times did it happen? Did it happen on more than one day?
5. Was the problem correlated with a specific maneuver or a specific geographic area?

6. Can the problem be repeated reliably?
7. Did the onset of the problem occur shortly after a software upload to the G5?
8. Was there a loss of the GPS position lock?

9.6 Heading Failure Troubleshooting (with GMU 11)

If a Red-X (steady or intermittent) is displayed in the heading field on the G5, check the following while the aircraft is on the ground:

1. When taxiing, heading performance is susceptible to the presence of magnetic anomalies (metal buildings, underground steel culverts, steel grates in the ramp, rebar, etc.). Localized sources of interference on the ground may consistently cause a Red-X to be displayed on the heading in the same location while taxiing; this is not caused by a failure of the GMU 11 or its calibration.
2. If any new equipment has been installed on the aircraft, conduct the magnetometer interference test procedure (see [Section 8.4.6.5](#)) to see if the new equipment is causing magnetic interference with the GMU 11.
3. With the G5 in configuration mode, select the Device Information page and verify there is a green checkmark next to MAG. If there is a Red-X next to MAG, inspect and verify the CAN bus wiring between the G5 and GMU 11. See the CAN bus troubleshooting steps in [Section 2.2.8](#).
4. If the problem persists, replace the GMU 11 with a known good unit.

9.7 G5 Data Logging

Data logging on the G5 may be used to help troubleshoot issues. Operational data can be gathered from the G5 during flight or on-ground and is stored in *.csv log files on the microSD™ card.

To enable logging on the G5:

1. Power on the unit in configuration mode.
2. Navigate to the Data Log Configuration page (via the Device Information and Diagnostics pages).
3. Select Enabled for the Data Card Log setting.

9.8 Sending Troubleshooting Data to Garmin

To assist with troubleshooting an issue, it may be helpful to send pictures and/or the log files stored on the microSD™ card to Garmin. This data can be especially useful to troubleshoot autopilot, attitude, and air data related issues. This data can be sent to g3xpert@garmin.com for troubleshooting assistance.

10 MAINTENANCE

Periodic maintenance for the G5 is limited to the air data system as listed in Section 10.1. All other maintenance is "on condition" only. Instructions for Continued Airworthiness (ICA) are not required per 14 CFR Part 21 for these products as they have received no FAA approval or endorsement. Garmin recommends that the G5 be inspected for proper operation, secure attachment, integrity of connectors and wiring, cleanliness, leakage of hoses and tubes, and any evidence of damage as part of the required annual or periodic aircraft inspection. For more general inspection guidance, please refer to the applicable sections of CFR Part 43 Appendix D and Chapter 12 of AC 43.13-1B.

10.1 G5 Air Data Periodic Maintenance

Per Part 43 Appendix E, paragraph (b)(2), Garmin recommends a test procedure equivalent to Part 43 Appendix E, paragraph (b)(1), with two exceptions. The tests of sub-paragraph (iv) (Friction) and (vi) (Barometric Scale Error) are not applicable because the digital outputs of the G5 are not susceptible to these types of errors. This procedure is recommended when the static system is opened up (i.e. whenever the G5 is removed or replaced). Garmin also recommends that a leak test be performed following any maintenance action in which the pitot system is opened up.



NOTE

If the G5 is moved or replaced, the Post Installation Calibration Procedures (Section 8.4.6) must be repeated.

10.2 G5 Battery Periodic Maintenance

For maximum battery longevity, store within a temperature range of -4°F to 68°F (from -20°C to 20°C). The G5 battery should be kept partially charged when unused for longer periods of time and should not be stored when completely discharged. Charge the battery to 30% within 1 year of receipt and recharge to 30% every 2 years thereafter if the G5 is not in use.

10.3 Return to Service Information

These return to service procedures are intended to verify the serviceability of the appliance only. These tests alone do not verify or otherwise validate the airworthiness of the installation.



NOTE

A pitot/static check as outlined in 14 CFR 91.411 and Part 43 Appendix E must be completed if the pitot/static lines are broken.

10.3.1 Original G5 is Reinstalled

No software or calibration is required if the original G5 is reinstalled in its original mounting location.

10.3.2 New G5 is Installed

Any time a new G5 is installed, or an existing G5 is moved to a different mounting location, the pitch/roll offset calibration procedure ([Section 8.4.6.1](#)) must be performed. The correct G5 software version will automatically be loaded into the G5 from a connected GDU (if applicable). If a GDU is not connected, the unit software will need to be loaded via the front-facing microSD™ card slot. All unit configuration options will need to be selected as the G5 does not support a configuration module.

10.3.3 G5 installations With a GMU 11

For G5 installations that include a GMU 11, verify the heading display is accurate as indicated by the white numbers displaying the magnetic heading. Any time a GMU 11 is moved or reinstalled, a new magnetometer calibration is required ([Section 8.4.6.6](#)).

11 PERFORMANCE SPECIFICATIONS/LICENSING/COMPLIANCE

11.1 GPS Specifications

Table 11-1 G5 GPS Specifications

Characteristics	Specifications
Acquisition Time	a) Warm Start (position known to 10 nm, time known to 10 minutes, with valid almanac and ephemeris): Less than 5 seconds b) Cold Start (position known to 300 nm, time known to 10 minutes, with valid almanac): Less than 45 seconds c) Always Locate™ (with almanac, without initial position or time): Less than 60 seconds
Update Rate	5 Hz (continuous)
Positional Accuracy	< 10 meters

11.2 G5 Environmental Specifications

The G5 has an operating temperature range of -20°C to +60°C. The G5 will prevent operation from the battery when the battery is outside of this temperature range.

11.3 G5 Performance Specifications

Table 11-2 G5 Performance Specifications

Characteristic	Specifications
Pressure Altitude Range	-1,400 feet to 30,000 feet
Vertical Speed Range	±20,000 fpm
Airspeed Range	300 knots (indicated)
Mach Range	< 1.00 mach
Pitch/Roll Range	±360°
Pitch/Roll Accuracy	±1° (straight and level flight) ±2.5° (normal dynamic maneuvering)*
Rotation Rate Range	±499°/second (automatic recovery when exceeded)
Heading Accuracy (with Optional GMU 11)	±3° (straight and level flight) ±6° (normal dynamic maneuvering)*
Backup Battery (Optional)	Rechargeable Lithium-ion
Battery Life	Up to 4 hours

*Normal dynamic maneuvering is defined as bank angles less than 35° and pitch angles less than 15°.

Due to variations in the Earth's magnetic fields, the operational accuracy of the G5's heading (with optional GMU 11) is unknown in the following regions:

- North of 72° N for all longitudes
- South of 70° S for all longitudes
- North of 65° N between 75° W and 120° W (northern Canada)
- North of 70° N between 70° W and 128° W (northern Canada)
- North of 70° N between 85° E and 114° E (northern Russia)
- South of 55° S between 120° E and 165° E (south of Australia and New Zealand)

11.4 RS-232 Text Output Format

11.4.1 Electrical Interface

The output signals are compatible with RS-232C. Data is generated at the configured baud rate with a word length of 8 bits, one stop bit, and no parity.

11.4.1.1 General Message Output Format

The general text output message format is as follows:

- Escape character ('=' symbol [0x3D hex])
- ID character
- Version character
- Data characters (length determined by message ID)
- Checksum (2-character [1-byte] ASCII hex value that is the sum of all previous bytes including the escape character)
- Carriage return (0x0D hex)
- Line feed (0x0A hex)

An exception to the above is the GPS Data message, which is backwards compatible with the Garmin Simple Text Output format described at: http://www8.garmin.com/support/text_out.html. The GPS Data message has the following format:

- Escape character ('@' symbol [0x40 hex])
- Data characters
- Carriage return (0x0D hex)
- Line feed (0x0A hex)

All text output messages use only printable ASCII characters. For all messages, a value that is out of range, missing, not configured, uncalibrated, or otherwise invalid is indicated by replacing the corresponding bytes within the message with the underscore character ('_' symbol [0x5F hex]).

11.4.2 Attitude/Air Data Message Format

The Attitude/Air Data message is transmitted approximately 10 times per second.

Table 11-3 Attitude/Air Data Message Format

Field Name	Offset	Width	Units	Notes	Min	Max
Escape Character	0	1		'='		
Sentence ID	1	1		'1'		
Sentence Version	2	1		'1'		
UTC hour	3	2	hours		00	23
UTC minute	5	2	minutes		00	59
UTC second	7	2	seconds		00	59
UTC second fraction	9	2	10 ms		00	99
Pitch	11	4	0.1 degrees	positive = up	-900	+900
Roll	15	5	0.1 degrees	positive = right	-1800	+1800
Heading	20	3	degrees	magnetic (G3X backup install only)	000	359
Airspeed	23	4	0.1 knots		0000	9999
Pressure altitude	27	6	feet		-01000	+60000
Rate of turn	33	4	0.1 deg/sec	positive = right	-999	+999
Lateral acceleration	37	3	0.01 G	positive = leftward	-99	+99
Vertical acceleration	40	3	0.1 G	positive = upward	-99	+99
Unused	43	2				
Vertical speed	45	4	10 fpm	positive = up	-999	+999
Unused	49	3				
Altimeter setting	52	3	0.01 inHg	offset from 27.50°	000	400
Checksum	55	2	ASCII hex	sum of prev bytes		
CR/LF	57	2		0x0D/0x0A		
Total Length	59					

11.4.3 GPS Data Message Format

The GPS Data message is transmitted once per second.

Table 11-4 GPS Data Message Format

Field Name	Offset	Width	Units	Notes	Min	Max
Escape character	0	1		'@'		
UTC year	1	2	years	last two digits of UTC year	00	99
UTC month	3	2	months		01	12
UTC day	5	2	days		01	31
UTC hour	7	2	hours		00	23
UTC minute	9	2	minutes		00	59
UTC second	11	2	seconds		00	59
Latitude hemisphere	13	1		'N' = north		
				'S' = south		
Latitude degrees	14	2	degrees		0	90
Latitude minutes	16	5	0.001 minutes	minutes x 1000	0	59999
Longitude hemisphere	21	1		'E' = east		
				'W' = west		
Longitude degrees	22	3	degrees		0	180
Longitude minutes	25	5	0.001 minutes	minutes x 1000	0	59999
Position status	30	1		'g' = 2D GPS position		
				'G' = 3D GPS position		
				'd' = 2D diff GPS position		
				'D' = 3D diff GPS position		
				'S' = simulated position		
				'_' = invalid position		
Horizontal position error	31	3	meters		000	999
Altitude	34	6	meters	Height above/below MSL	-99999	+99999
East/west velocity direction	40	1		'E' = east		
				'W' = west		
East/west velocity magnitude	41	4	0.1 m/sec		0000	9999

Table 11-4 GPS Data Message Format

Field Name	Offset	Width	Units	Notes	Min	Max
North/south velocity direction	45	1		'N' = north		
				'S' = south		
North/south velocity magnitude	46	4	0.1 m/sec		0000	9999
Vertical velocity direction	50	1		'U' = up		
				'D' = down		
Vertical velocity magnitude	51	4	0.01 m/sec		0000	9999
CR/LF	55	2		0x0D/0x0A		
Total length	57					